



ACO KerbDrain® E Class

Combined kerb and drainage system

Product Catalogue



ACO KerbDrain®

ACO KerbDrain® is an award winning combined kerb and drainage system specifically designed and developed to form an integral part of any modern, sustainable surface water management solution. In recognition of ACO KerbDrain's ground breaking one-piece design, the system was awarded the Queen's Award for Enterprise: Innovation in 2001

ACO KerbDrain® HB305D

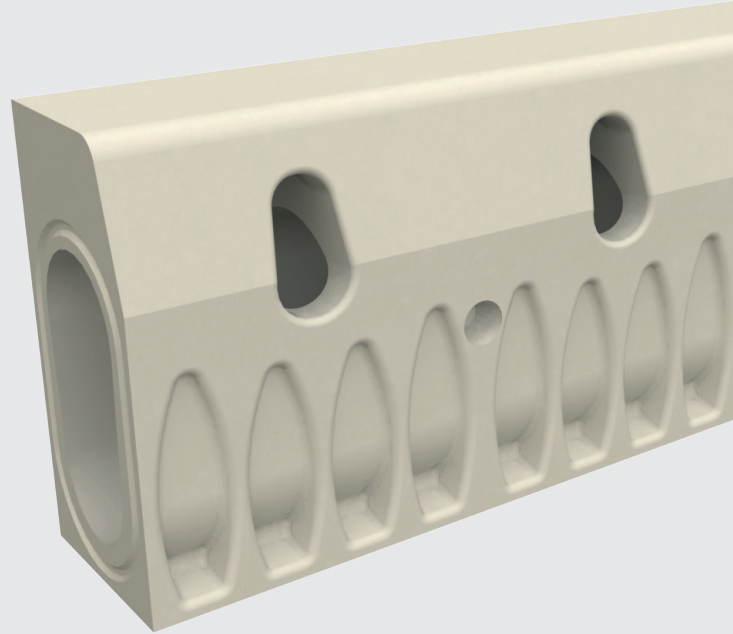

ACO KerbDrain® HB305E

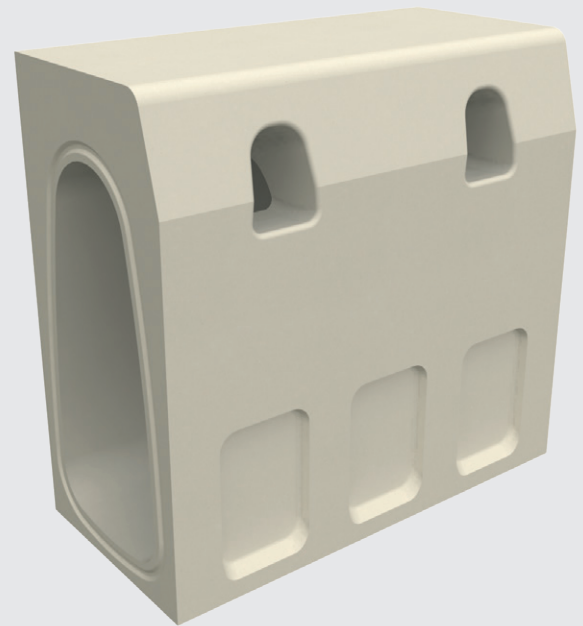
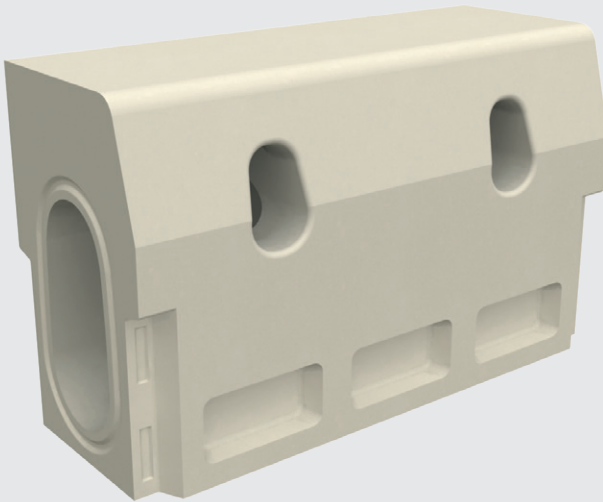

ACO KerbDrain® HB480E+

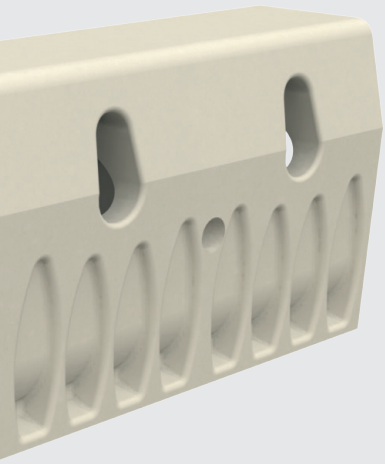

ACO. we care for water	4
Water protection and rainwater management	
What is ACO KerbDrain®?	6
Why choose ACO KerbDrain® E Class	8
ACO KerbDrain® E Class features overview	10
A range of solutions with ACO KerbDrain® E Class	12
ACO QuAD Hydraulic Design Software	14
Installation detail	16
Material benefits	18
ACO KerbDrain® E class range overview	20
ACO KerbDrain® Half Battered 305E system ACO KerbDrain® HB305E and components	21
ACO KerbDrain® Half Battered 480E system ACO KerbDrain® HB480E and components	22
ACO KerbDrain® Half Battered gully	23
ACO KerbDrain® E+ class range overview	26
ACO KerbDrain® Half Battered 370E+ system ACO KerbDrain® HB370E+ and components	27
ACO KerbDrain® Half Battered 480E+ system ACO KerbDrain® HB480E+ and components	28
Maintenance of ACO KerbDrain®	29
Design support service	30
ACO BIM Models	31
Further Learning	
ACO Professional Development	32
Case Studies	
Colab	

ACO. we care for water

ACO is a Water-Tech company that protects water. Building on our global drainage expertise that protects people from water, we increasingly see our mission as also protecting water from people.

With the ACO WaterCycle, ACO provides systems that collect and channel, clean, retain and ultimately reuse water. In this way, ACO contributes to the preservation of clean groundwater as a vital resource, and makes a contribution to tomorrow's world. In its Agenda 2030, the UN global community set the improvement of water quality as one of 17 sustainable development goals.

Intelligent drainage systems from ACO increasingly use smart technology to ensure that rainwater and wastewater are drained, or temporarily stored. With innovative separation and filter technology, we prevent water contamination by pollutants such as fat and grease, fuels, heavy metals and microplastics.

Today, ACO goes one step further: we accept the challenge of reusing water, and thus establishing a resource-saving cycle. For all products and systems, ACO attaches great importance to durability, reusability and a low carbon footprint. The pursuit of sustainability is an ongoing process that we strive to meet every day.

The ACO Group is a global family business that is one of the world market leaders in the Water-Tech segment. Founded in Schleswig-Holstein in 1946, it operates as a transnational network in over 50 countries. Worldwide, ACO is characterised by a high level of decentralised ownership, and explicit regional market proximity.

www.aco.com



Holder
Iver and Hans-Julius Ahlmann



Headquarters of the ACO Group
in Rendsburg/Büdeltsdorf



5,200

employees in more than 47 countries (Europe, North and South America, Asia, Australia, Africa)

1 Billion

Euro Sales in 2021

37

production sites in 18 countries



ACO Academy
for practical training

Water protection and rainwater management

What is ACO KerbDrain®?

The ACO KerbDrain® combined kerb and drainage system provides versatile and efficient linear drainage for motorways, trunk roads, urban infrastructure and landscaping projects. Its award winning one-piece design, provides quick and easy installation and high impact performance in both SuDS schemes and traditional drainage systems.

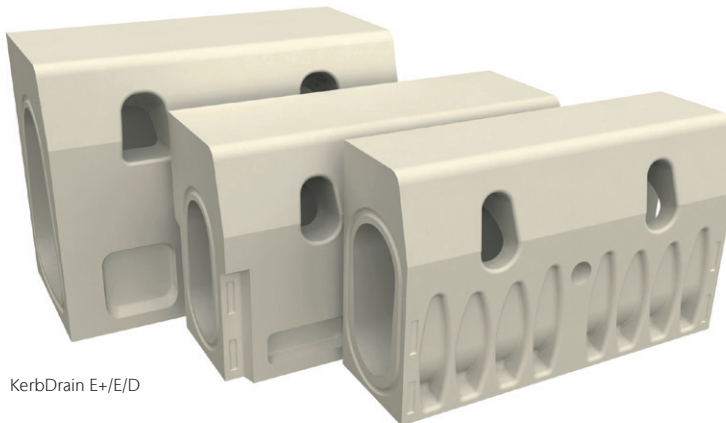

KerbDrain E+/E/D

ACO KerbDrain® has a full range of D 400 combined drainage and kerb, which satisfies the vast majority of highways, commercial and car park drainage needs. The range has expanded to E 600 Load Class to meet specific requirements where impact is more likely. ACO has satisfied the desire for higher capacity kerb drainage where there are large catchment areas, with the inclusion of the E+ Range.

ACO KerbDrain® has a range of units to match HB1, HB2 and 45° splayed profiles, in a range of depths, which enable engineers and designers to optimise scheme hydraulics for efficient and economical drainage.

It removes problems associated with incorrectly sited point gullies by ensuring all surface water runoff is safely removed over the entire length of the installation. The one-piece construction of ACO KerbDrain® and the lightweight properties of Vienite® ensure the system is quick and easy to install, even when a fully watertight installation is required.



Why choose ACO KerbDrain® E Class

ACO KerbDrain® E Class range is CE and UKCA marked in accordance with the Construction Products Regulation.

Declarations of Performance are available via the CPR Zone on our website (www.aco.co.uk/DoP.php), or on request. Please contact ACO Water Management Design Services Team on 01462 816666 for further assistance.

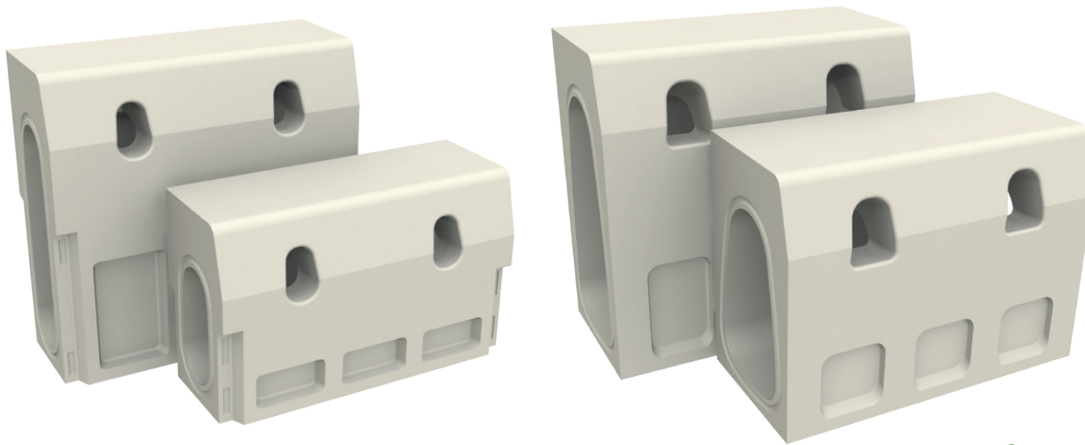

Product features

- Impact resistance 50% higher than OPC kerb units
- Manufactured from sustainable material
- Certified for all highways applications
- Problem solving components for all sizes
- Capacity choices optimise hydraulic performance
- One-piece design E 600 load class
- Simple watertight installations if required
- Safe manual and mechanical handling
- High daily installation rate

ACO KerbDrain® E Class range meets the highest levels of certification, performance and quality assurance for combined kerb drainage systems. It is fully certified to Load Class E 600 BS EN 1433:2002, meeting National Highways requirements for units located in areas subjected to large numbers of high speed heavy goods vehicles, and is both CE and UKCA marked. They are 50% more impact resistant than traditional OPC kerb units.

ACO KerbDrain® E Class range carries the BSI Kitemark, independently assuring performance and quality and making the system fully compliant with the Specification for Highways. Works Clause 516 and all National Highways product and certification requirements.

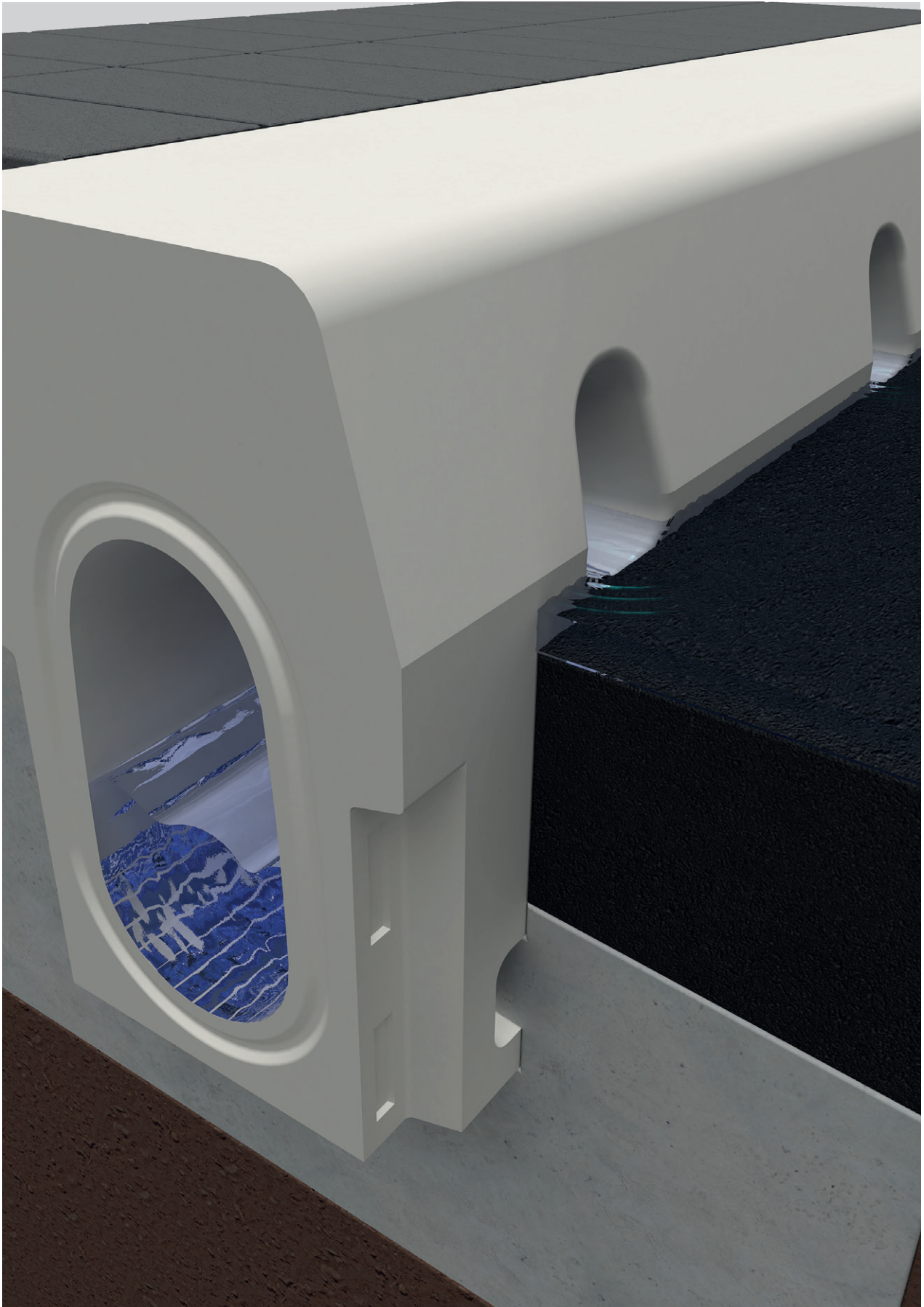

ACO KerbDrain® E Class features overview

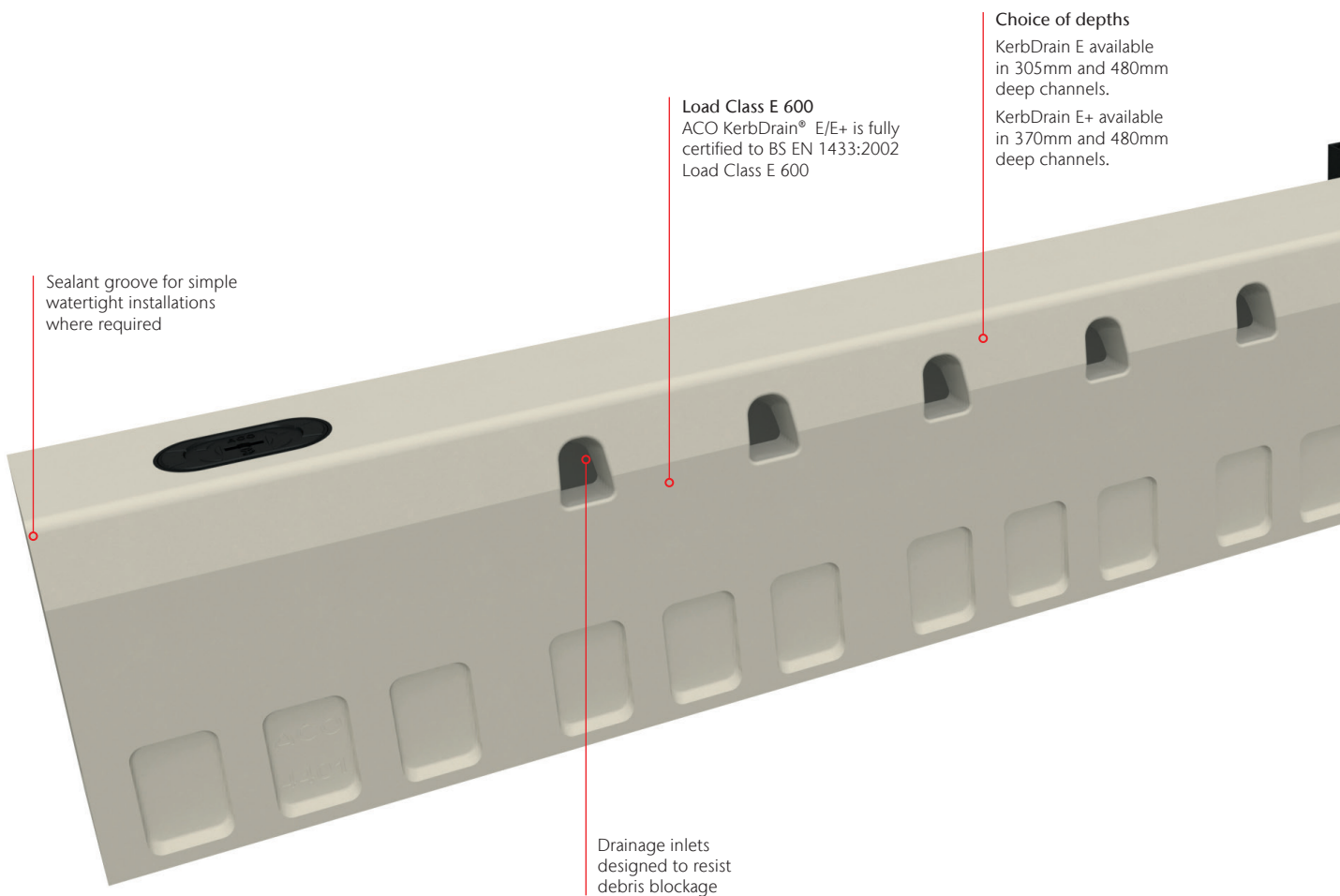

Sealant groove for simple watertight installations where required

Load Class E 600
ACO KerbDrain® E/E+ is fully certified to BS EN 1433:2002 Load Class E 600

Choice of depths
KerbDrain E available in 305mm and 480mm deep channels.
KerbDrain E+ available in 370mm and 480mm deep channels.

Drainage inlets designed to resist debris blockage

Load Classes



A 15
Pedestrians and cycleways



B 125
Pedestrian precincts, light vehicles, private car parks and drives



C 250
Parking areas, service stations (cars) and slow-moving light commercial vehicles



D 400
Public highways, parking areas for all types of vehicles, distribution yards



E 600
Industrial areas, heavy wheel loads, HGV's and forklifts, service stations.

Made from sustainable materials
Thermally stable, chemically resistant, environmentally friendly product manufactured from Vienite® material. For more information on Vienite® see page 20.



Various gully options available and can be used to transition between E and E+ channels

External surfaces anchor channel securely into concrete surround to prevent displacement

50% higher impact resistance than traditional OPC kerbs

Transition unit (available 2022) allow connection to KerbDrain D 400 Load Class channels (either directly D/E or through the gully D/E+)

National Highways Compliant
KerbDrain E/E+ complies with IAN 117/08, Clause 516 SHW and is Kitemarked to BS EN 1433:2002 for highway use

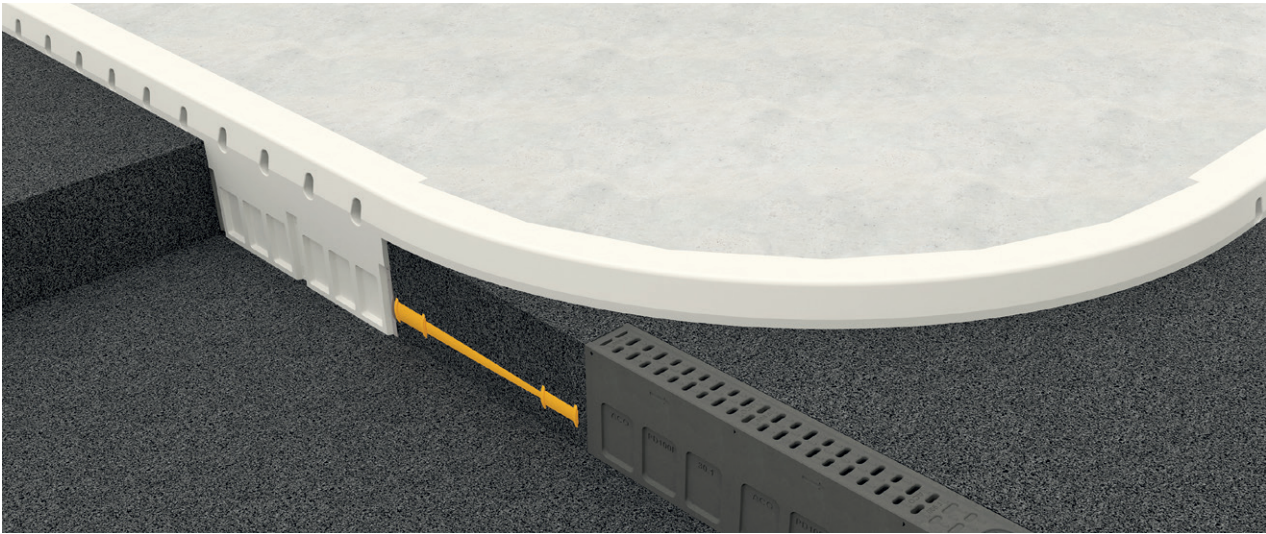
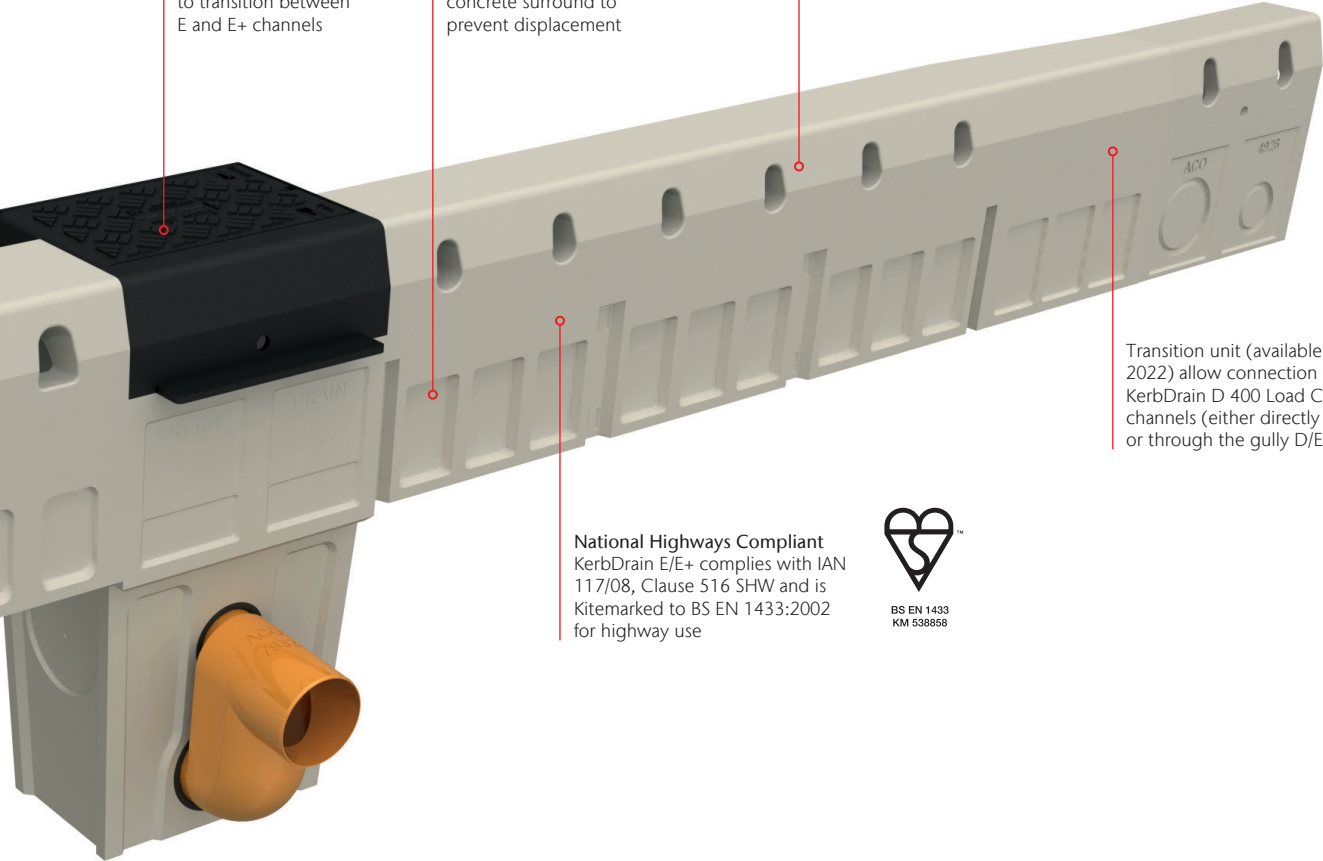

Connection to RoadDrain

A range of solutions with ACO KerbDrain® E Class



Tunnels

PROBLEM:

Installation depths within tunnel construction can be restricted. Yet in the event that high volumes of hazardous liquid are discharged onto the road surface, such as a tanker spillage, rapid collection and containment is paramount for the safety of road users and the environment.

SOLUTION:

The compact nature of ACO KerbDrain® E Class range combined with its high hydraulic capacity makes it ideal for use within the confines of a tunnel. Liquid-tight installations can quickly and efficiently be achieved to ensure that any hazardous liquids entering the ACO KerbDrain® system are contained prior to safe removal. The image shows ACO KerbDrain® HB480E kerb units being used to provide drainage of a tunnel.



SuDS

PROBLEM:

Providing a Sustainable Drainage System (SuDS) for new and redevelopments can present engineers and designers with significant challenges to deal with the quality, quantity and amenity of the surface water runoff. Restrictions of space, local topography or site specific conditions such as high natural water tables can mean that “Soft SuDS” solutions alone are unsuitable.

SOLUTION:

ACO KerbDrain® can be successfully used in SuDS schemes by allowing engineers and designers to combine the benefits of “hard SuDS” such as combined kerb drainage with traditional “soft SuDS” solutions such as swales, ponds and wetlands. ACO KerbDrain® E Class can be used to provide drainage of a highway in conjunction with a swale.



T-Junctions

PROBLEM:

Where side roads adjoin the main carriageway, flow of surface water along the gutter can be impeded or prevented leading to standing water and drainage issues. Surface water runoff from side roads entering the main carriageway can also be a hazard to road users.

SOLUTION:

The combination of D 400 and E 600 Load Class KerbDrain units provides the necessary products to effectively drain the road junction, from mitred and radius units for the corners to dedicated junction channels and end caps that provide continuous and effective interception and drainage of surface water flows across the junction. The 500mm length makes it easy to install round large radii like T junctions and roundabouts.



Roundabouts

PROBLEM:

Complex carriageway cross-falls created in the construction of roundabouts can make it extremely difficult to site traditional point gullies correctly to capture standing water which can be hazardous to motorists and cyclists.

SOLUTION:

ACO KerbDrain® E Class units are 500mm in length which can be installed to create external and internal radii to ensure efficient drainage of the curved perimeters found at roundabouts. ACO KerbDrain® E Class units have multiple surface water inlets providing continuous linear drainage of the entire carriageway. The E 600 Load Class and durable material makes it ideal for roundabouts which may experience high occurrences of vehicular impact.



Highways and Trunk Roads

PROBLEM:

With higher volumes of traffic than suburban roads major highways and trunk roads will see more examples where vehicles impact the roadside kerbs. There will also be a need for greater hydraulic capacity for combined kerb drainage systems.

SOLUTION:

ACO KerbDrain® E+ provides the ability to drain higher volumes than the standard KerbDrain® range and the product is also certified to E600 load classification making it stronger than the standard KerbDrain® range.



Large Car Park

PROBLEM:

Car park design aims to maximise car park spaces and customer safety whilst also ensuring that the large catchment areas are drained efficiently. Combining site requirements and ensuring capacity for high storm events require higher capacity channels.

SOLUTION:

ACO KerbDrain® HB370 E+ and HB480 E+ channels offer up to 70% greater hydraulic capacity than the standard KerbDrain® D 400 range. The products are also certified to E 600, which means they provide a tougher solution that can be required when installed in areas more prone to vehicle strikes like car parks.

ACO QuAD Hydraulic Design Software

Try our free design tool

The free-to-use ACO QuAD Hydraulic Design software has unprecedented levels of choice and flexibility built-in, to enable the efficient and accurate hydraulic design of any surface water management scheme.



The hydraulic engine has been robustly tested and is the tool used by ACO's own internal Design Services Team in modelling surface water solutions for customers.

ACO QuAD Hydraulic Design software uses differential equations for spatially varied flow that online alternative solutions cannot accurately match. For example the Manning's equation for steady uniform flow does not work with level channels and is grossly inaccurate on shallow gradients.

Here are some of the features it includes:

- Powerful project-based software
- Create catchment models that are fully editable
- PDF summary document output
- Cloud based – All designs are stored securely on our server against your login
- Integrated rainfall data for the whole of the UK

QuAD Features Overview

Cloud based

The software means increased efficiency providing design resources you need when you need it, allowing you to deploy the same design capability consistently, with the same consistency in results every time.



Flexible catchment design

QuAD is designed to support designers in the creation of catchment areas. Supplementary catchment areas can easily be added upstream and downstream of any previously designed channel run.



Product + value optimiser

Optimising the specific channel runs can be done with the optimiser feature selecting the smallest product suitable. Excavation and concrete requirements are also provided.



Attenuation assessments

Calculate the attenuation required for the project and compare it with the storage available in the channel design. Attenuation volume is presented along with suitable options for storage.



Flexible download format

Output can be generated for all or parts of the project and can be generated in pdf or CSV formats.



Application

Application selection ensure designers are able to get quick and accurate guidance in selection of the most suitable products based on the type of application the catchment is to cater for.



Rainfall assist

Rainfall intensity by location matters in design. QuAD provides a site locator map enabling the most accurate intensity to be input.



Resilience assessment

By inputting anticipated sedimentation rates and sedimentation density the QuAD software enables the designer to test their suggested maintenance schedules.



Secure scheme filing

All designs created by registered users are stored on a secure server and are password protected. Past projects are easily retrieved from the personalised menu.



Fully supported

There is support available either through a query submission or through self-help made possible by the comprehensive Knowledge database.



Installation detail

Load class

Installation recommendations shown are ACO minimum recommendations for BS EN 1433:2002 load class requirements.

Ground conditions

The long term performance of a channel installation to sustain vertical and lateral loads depends upon:

- A) Ground conditions
- B) Stability of the adjacent pavement
- C) A durable concrete bed and surround

The recommended installation detail may require the minimum dimensions to be revised to achieve site specific load class requirements.

Cutting and jointing

Mitre joints are formed by cutting the channels to the required angle and butting them together with appropriate sealant (e.g. Sikaflex 11FC or similar) or the ACO Repair Kit. Angles can be formed using radius or mitre units or by connecting them using proprietary PVCu pipework attached to ACO inlet/outlet endcaps. For further details please contact ACO Design Services Team.

Note: Where requested ACO can custom manufacture angled units to order.

Isolation joints

The channel must be isolated from the surrounding environment. An isolation joint must be positioned up to a maximum of 1500mm from the channel wall. Any dowel bars must be located no nearer than 150mm from the channel wall. Other isolation joints in surrounding slab must be continued through the channel. Additional crack control may be required to comply with specifier requirements.

Block pavements

The channel must be supported laterally. Blocks laid directly against a channel must be laid as a soldier course and restrained from movement by bedding securely on the concrete haunch e.g. by using a polymer modified mortar for bed and perpendicular joints (e.g. RONAFIX mortar mix C or similar). Alternatively, extend concrete haunch up to finished paving level (as depicted in Option 2). Blocks or slabs bedded on sand remote from the channel should be set at a higher level to compensate for possible settlement of the paving in service.

ACO KerbDrain® E units

Full electronic versions of ACO KerbDrain installation details should be referred to, diagram below for general information. Full details are available to download from the ACO website. Visit www.aco.co.uk.

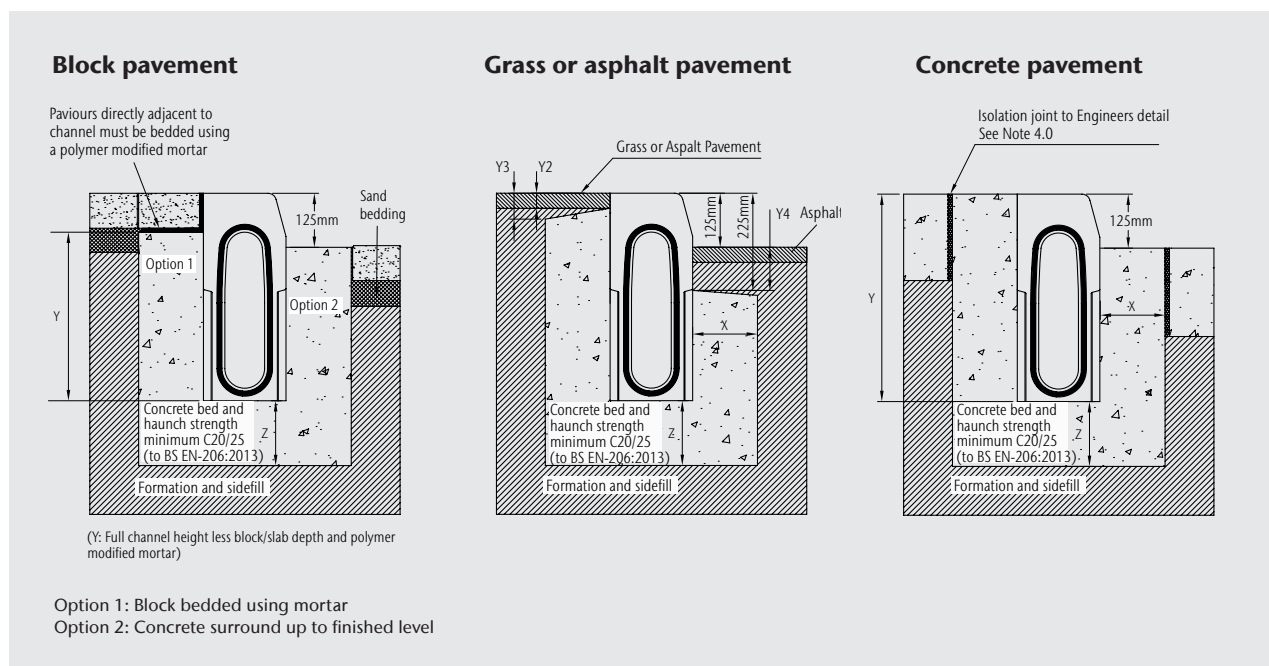

Watertight installation to BS EN 1433:2002

Where ACO channel joints/fittings and channel/pavement interfaces are to be sealed, an appropriate sealant should be used (e.g. Sikaflex 11FC or similar). Guidance on the necessary surface preparation and/or priming should be sought from the sealant manufacturer.

Best practice and workmanship

ACO can give guidance with respect to the most suitable methods of installation for each of the products in the ACO KerbDrain® range. ACO KerbDrain® should be installed using acceptable levels of workmanship and according to the National Code of Practice (UK: BS8000: Part 14: 1989) in keeping with EN 1433:2002 (Drainage channels for vehicular and pedestrian areas).

Detailed installation statements and methodologies will vary for all sites as each will have different aspects deserving particular consideration, consequently the relevant approvals should be sought from the consulting engineer and/or the installer.

For further information please contact our Design Services Team (technical@aco.co.uk) or the ACO website www.aco.co.uk.

Concrete surround dimensions

E/E+ Load Class			
Dimension	A 15 – C 250	D 400*	E 600*
X	Min 150mm	Min 150mm	Min 150mm
Y	Full channel height (less Y2 where necessary)		
Y2	Max 35mm*	Max 35mm*	Max 35mm*
Y3	Max 60mm*	Max 60mm*	Max 60mm*
Y4	No front haunch	Max 100	Max 100
Z	Min 150mm	Min 150mm	Min 150mm
Minimum compressive strength to BS EN-206:2013	25 N/mm ²	25 N/mm ²	25 N/mm ²

* Where regular HGV impacts are anticipated (e.g. roundabouts), we recommend that the concrete backing is laid to the top of the ACO KerbDrain® unit. (i.e. Y2=0, Y3=0)



ACO's Polymer concrete repair kit is available for bonding applications, or for the repair of small areas of aesthetic damage. For further product details please see page 21.

ACO KerbDrain® E+ units

Full electronic versions of ACO KerbDrain installation details should be referred to, diagram below for general information. Full details are available to download from the ACO website. Visit www.aco.co.uk.

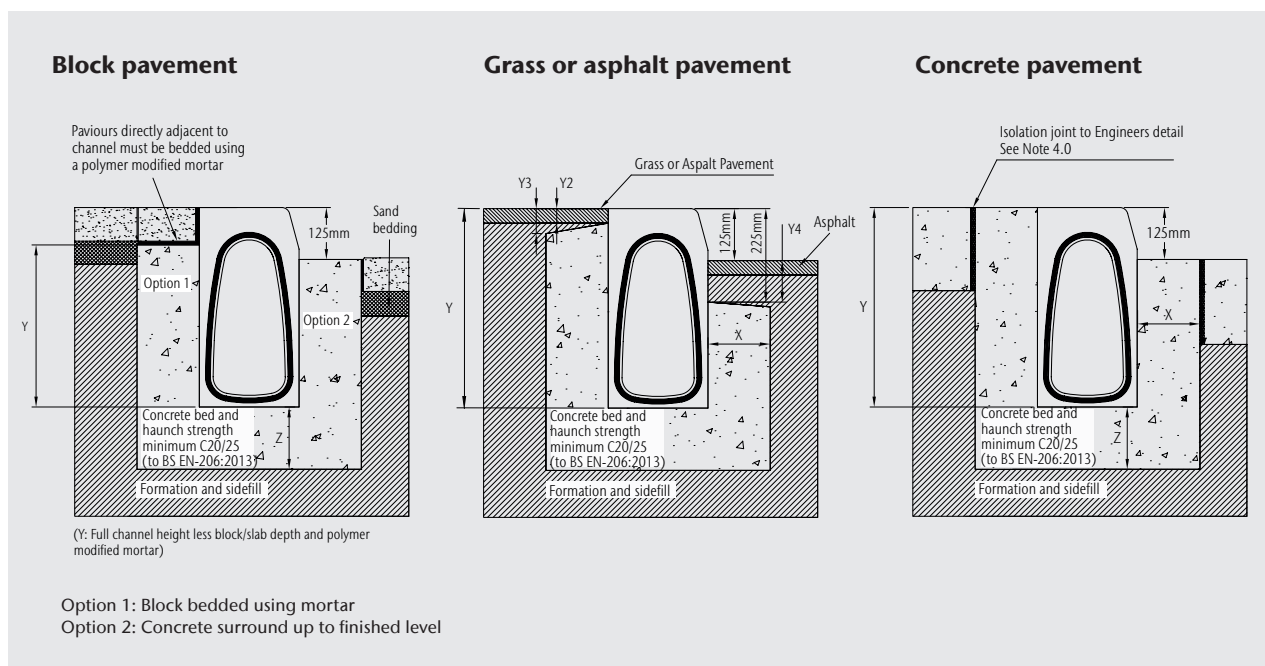

Material benefits

The correct material selection for products installed in permanent works is extremely important to assure optimum performance throughout its design life.



ACO KerbDrain® is manufactured from Vienite®, ACO's sustainable high strength material. This material offers distinct advantages over other products and materials, addressing key specification and performance requirements for engineers and designers.

Sustainable use of materials

Efficient use of material resources is a key contributor to sustainability in construction. ACO KerbDrain® has been carefully designed to maximise strength while minimising material use.

- Vienite® combines the mechanical and performance benefits of synthetic resin concrete with high levels of recycled fillers.
- Vienite® is a sustainable material that contains between 5% to 30% by weight post consumer waste previously destined for landfill in the UK
- Vienite® fully conforms to and exceeds all performance requirements as specified by BS EN 1433:2002 for combined kerb drainage units.
- ACO KerbDrain® manufactured from Vienite® holds BSI Kitemark Certification as a result of continuing independent verification of material performance by BSI.
- Vienite® is recyclable, i.e. it can be collected, processed and returned for re-use as a raw material.

The ACO KerbDrain® range also includes components manufactured from ductile iron and steel which contain between 25% and 90% recycled material.

Mechanical properties of Vienite®

The following data compares the advantages of Vienite® used to manufacture ACO KerbDrain® with Ordinary Portland Cement (OPC) concrete and recycled plastic composite materials.

Compressive strength

Vienite® has high compressive strength is therefore extremely resistant to service loads.

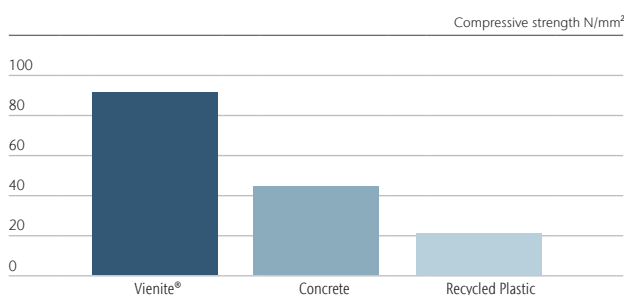

Flexural strength

Vienite® has excellent flexural strength making the product resistant to side loads typically encountered during surfacing and installation.

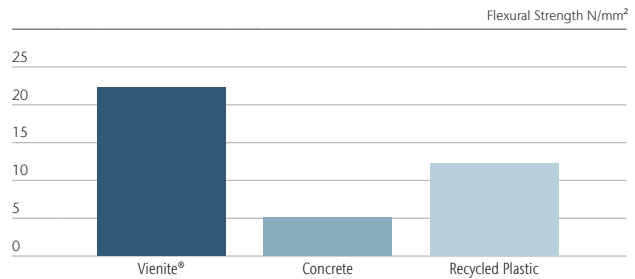

Coefficient of thermal expansion

Vienite® has a low coefficient of thermal expansion making it extremely stable, and unlike some materials it will not buckle or distort if subjected to high or low temperatures during service.

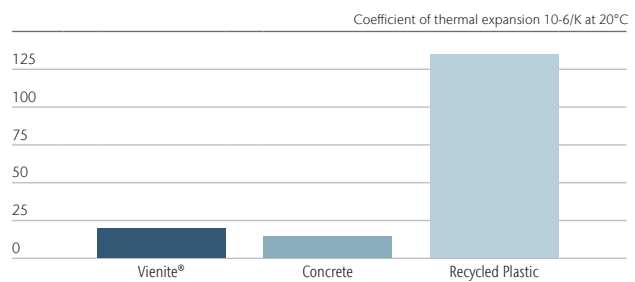

Impact resistance

ACO KerbDrain's optimised design combined with the nature of Vienite®, makes it highly resistance to damage typically caused during installation or from traffic impacts. ACO KerbDrain® has been proven to be 50% more resistant to impact damage than traditional OPC concrete kerb stones*.

* Tested by Birmingham City Laboratories (BCL)

Water absorption

Vienite® has low water absorption of only 0.01% by weight which means surface water or liquids are contained within the product until discharge without contaminating surrounding soil or groundwater.

Coefficient of friction (Mannings)

Vienite® is extremely smooth having a Mannings coefficient of 0.011 giving enhanced hydraulic performance and resisting the build up of silt and debris.

Chemical resistance

Vienite® has high resistance to dilute acids and alkalis and is unaffected by road salts, fuels and oils which are typically encountered during service. For a copy of our full chemical resistance chart for Vienite® please contact our ACO Water Management Design Services Team.

Model specification clause

The combined kerb drainage system shall be ACO KerbDrain® as supplied by ACO Technologies plc. All materials and components within the scope of the system shall be supplied by this manufacturer. The kerb drainage units shall be fully compliant with BS EN 1433:2002 with Initial Type Test certification issued by a notified body independent of the manufacturer and shall comply with the Manual of Contract Documents for Highway Works: Specification of Highway Works, Clause 516. The kerb drainage units shall be certified by a third party product certification system compliant with BS EN 45011:1998 carried out by an accredited body (UKAS or equivalent), e.g. Kitemark.

All units shall be of one piece manufacture from Vienite®. Vienite® is a sustainable material that contains between 5% to 30% by weight post consumer waste previously destined for landfill in the UK

The standard units shall be installed with the manufacturer’s gullies, access units and accessories as required for the scheme. The system shall be installed in accordance with the manufacturer’s printed recommendations, and the works carried out as specified on drawings (*) and in accordance with recognised good practice. Standards of workmanship shall generally be as specified in BS EN 752 and BS8000:Part 14:1989.

*Please insert drawing no. relevant to the project.

Highways specification – appendix 5/5

The Appendix 5/5 will need to be completed for each project. A model Appendix 5/5 for ACO KerbDrain® E/E+ range is available from the ACO Water Management Design Services Team.



The ACO KerbDrain® system is CE and UKCA marked in accordance with the Construction Products Regulation.

Declarations of Performance are available via the DOP data zone on our website (www.aco.co.uk/DoP.php), CPR data on the product page, or on request. Please contact ACO Water Management Design Services Team on 01462 816666 for further assistance.

BS EN 1433:2002



ACO KerbDrain® E Class range overview

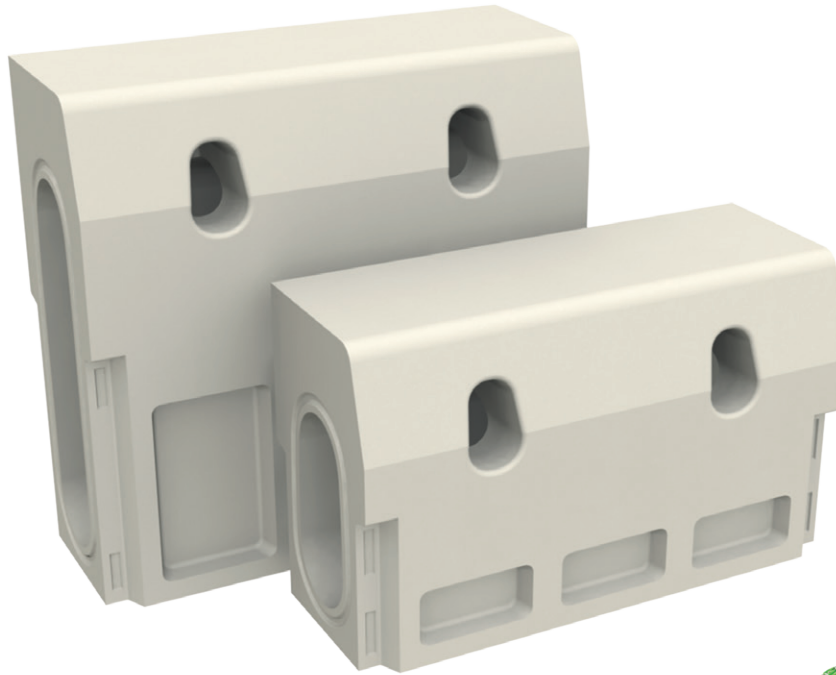







The ACO KerbDrain® E Class range has a half battered profile to match a British Standard HB profile. The range is ideal for draining medium size catchments such as urban highways or parking areas. Its E 600 Load Class is suited for higher impact areas, like roundabouts and urban highway applications with large numbers of high speed HGV's.

ACO KerbDrain® E Class range is available in 0.5m lengths with the following components:

- Access units
- Gully units
- Multifunctional end caps
- Transition units D 400 to E 600*



 HB Profile	 Kitemarked
305mm 480mm Unit depth	 CE and UKCA approved
 Hydraulic capacity	 0.5m units
320m ² 1150m ² HB305E catchment area HB480E catchment area	 Gully unit for transitioning
 Load Class	

*Transition units not available at initial launch, please enquire as to available date

ACO KerbDrain® HB305E

Product Code	Description	Length [mm]	Width Overall [mm]	Depth [mm]	Invert Depth [mm]	Weight [kg]
HB305E half battered KerbDrain®						
32002	KerbDrain® HB305E channel 500mm E 600	500	190	305	280	39.7
32003	KerbDrain® HB305E access unit 500mm E 600	500	190	305	280	38.9
32033	KerbDrain® HB305E LH gully or D/E transition unit D 400	500	190	305	280	36.7
32032	KerbDrain® HB305E RH gully or E/D transition unit D 400	500	190	305	280	36.7

HB305E 500mm unit

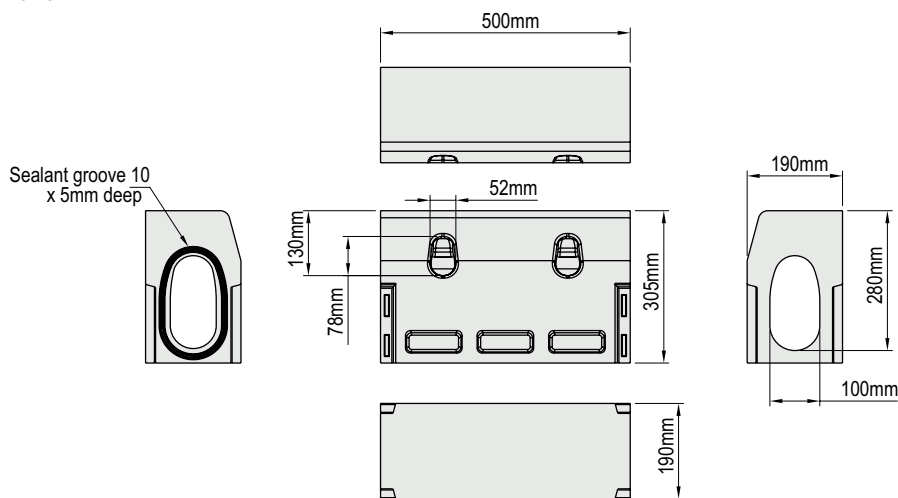

HB305E 500mm access unit

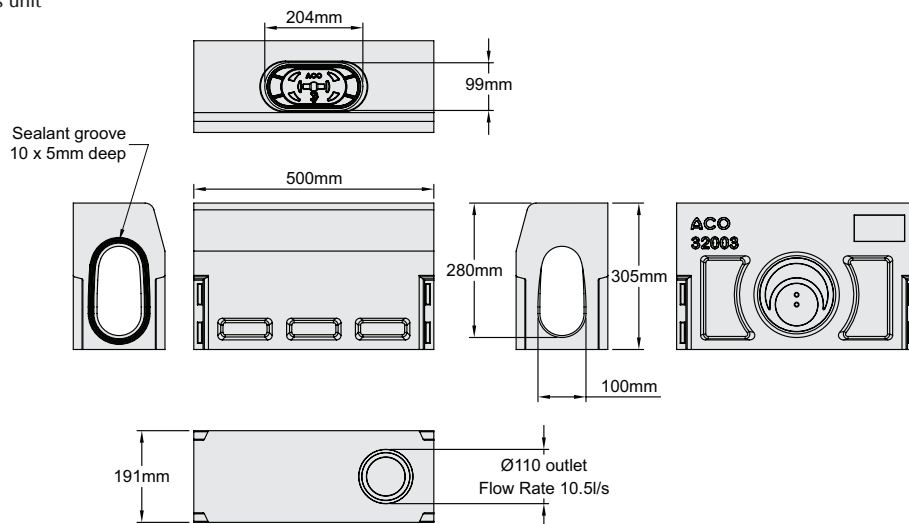

HB305 D/E multifunctional end cap

4941	KerbDrain® HB305 D/E multifunctional end cap	3	160	245	n/a	0.16
32599	Polymer concrete repair kit	-	-	-	-	1

Product Code	Description	Length [mm]	Width Overall [mm]	Depth [mm]	Invert Depth [mm]	Weight [kg]
HB480E half battered KerbDrain®						
32006	KerbDrain® HB480E channel 500mm E 600	500	190	480	455	53.7
32007	KerbDrain® HB480E access unit 500mm E 600	500	190	480	455	52.9
32037	KerbDrain® HB480E LH gully or D/E transition unit D 400	500	190	480	455	47.8
32036	KerbDrain® HB480E RH gully or E/D transition unit D 400	500	190	480	455	47.8

HB480E 500mm unit

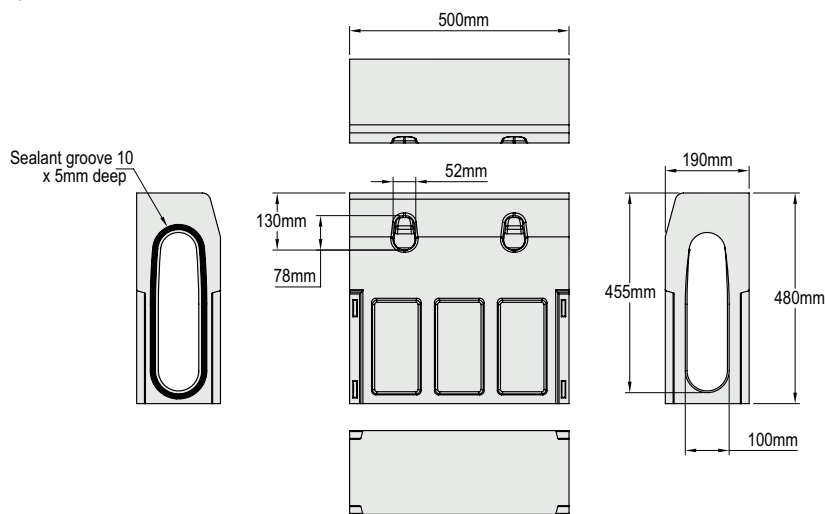

HB480E 500mm access unit

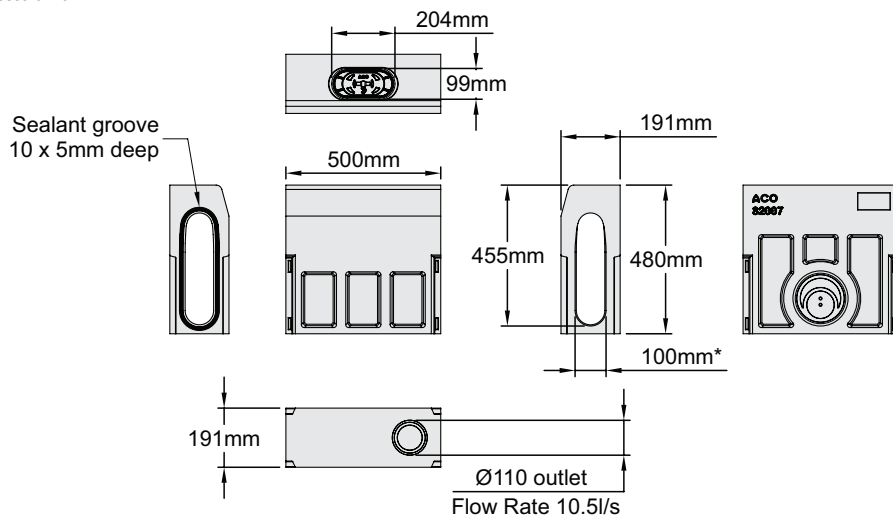

HB405 & HB480 D/E multifunctional end cap

4249	KerbDrain® HB405 & HB480 D/E multifunctional end cap	3	160	420	n/a	0.32
------	---	---	-----	-----	-----	------

ACO KerbDrain® half battered gully



ACO KerbDrain® half battered gully units provide the outfall connection of the system to traditional underground drainage or road gullies, management of silt, and access for maintenance and cleaning. *KerbDrain gully units featured in the D Class range brochure are not compatible with E/E+ channels. Using D class KerbDrain with this gully will require the use of a transition unit (pages 21-22).

Gullies are supplied with a ductile iron cover and frame and a polymer concrete unit for channel connection. These two components form the top assembly for all ACO KerbDrain® gully options. The ductile iron cover of the top assembly is lockable and for improved safety to road users can be orientated to suit traffic direction.

The ACO KerbDrain® D/E/E+ gully top assembly can be specified on its own or in conjunction with four Vienite® polymer concrete base options which allow drainage designs to be optimised for silt and hydraulic capacity or outlet connection.

Available gully base options are shallow and deep units, deep unit with roddable foul air trap or Ø450mm road gully connector. Gully base units are provided with outlet connections for Ø160mm, Ø200mm and Ø225mm pipe and supplied with a galvanised steel gully bucket. For full details please see table that follows.

ACO KerbDrain® half battered gully

Product Code	Description	Length [mm]	Width Overall [mm]	Depth [mm]	Invert Depth [mm]	Weight [kg]
32017	KerbDrain® HB-D/E/E+ Gully Access Top Assembly E 600*	500	390	520	-	90
32018	KerbDrain® HB-D/E/E+ Gully Assembly Shallow E 600*	500	390	870	848	123
32019	KerbDrain® HB-D/E/E+ Gully Assembly Deep E 600*	500	390	1025	970	132
32020	KerbDrain® HB-D/E/E+ Gully Assembly Deep with Roddable Foul Air Trap E 600*	500	390	1025	788	133
32021	KerbDrain® HB-D/E/E+ Gully Top Assembly and Ø450mm Adaptor E 600*	500	390	823	-	139

KerbDrain HB Gully Access Top Assembly E600

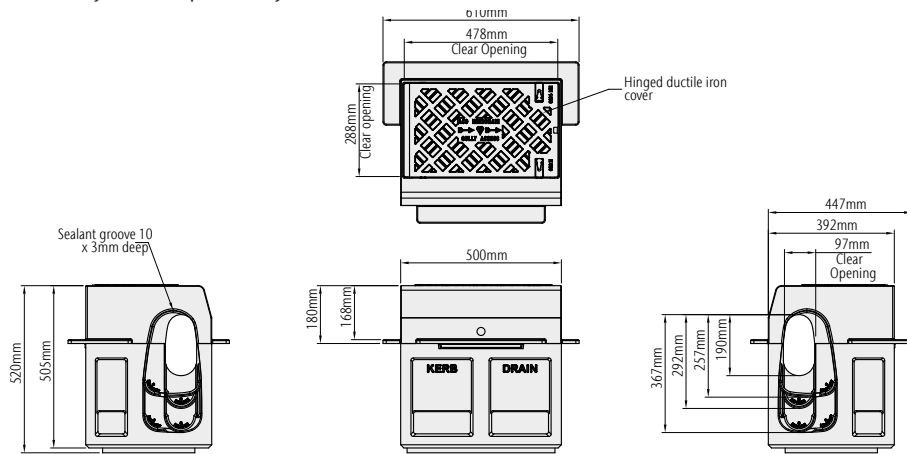

KerbDrain HB Gully Shallow E600

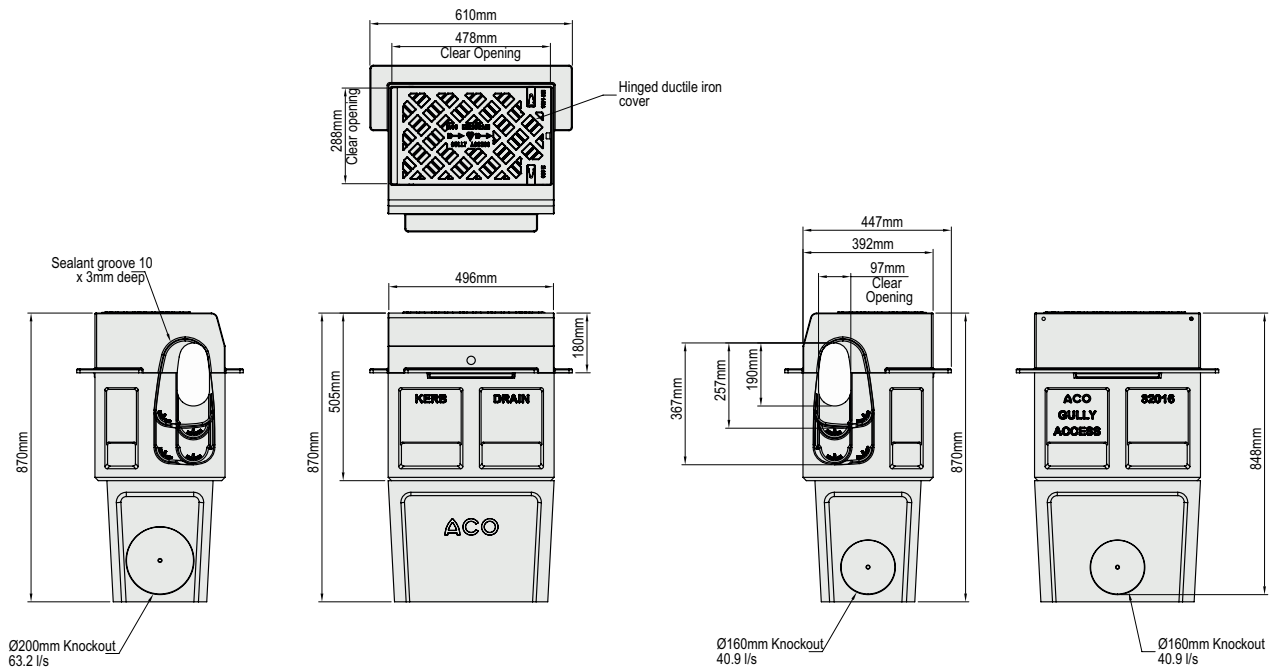

These products are subject to weight and dimensional tolerances. The dimensions shown on this page are for guidance purposes only.

* Using D class KerbDrain with this gully will require the use of a transition unit (pages 21-22).

ACO KerbDrain® half battered gully

KerbDrain HB Gully Assembly Deep with Roddable Foul Air Trap

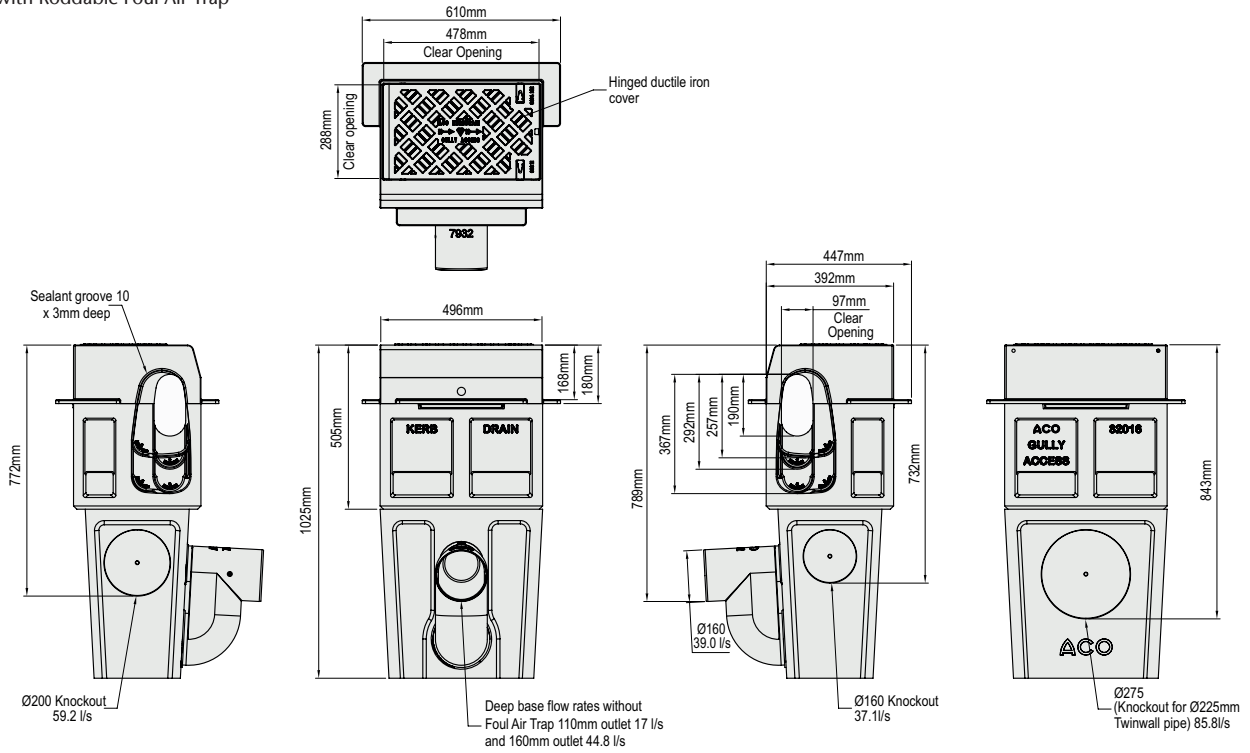

KerbDrain HB Gully Top Assembly and with Ø450 Adaptor E600

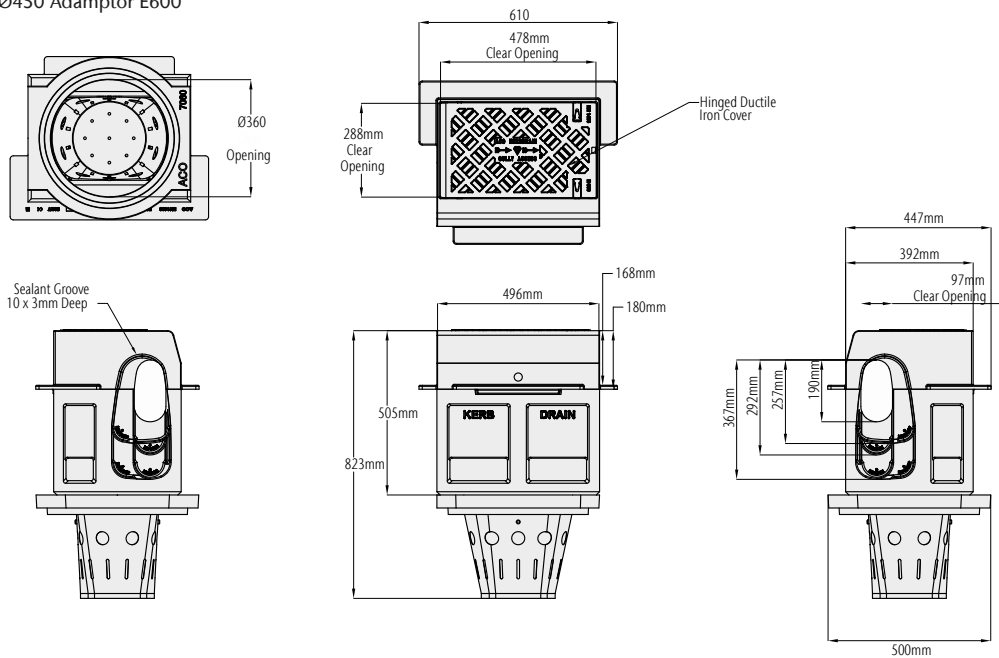

ACO KerbDrain® E+ Class range overview

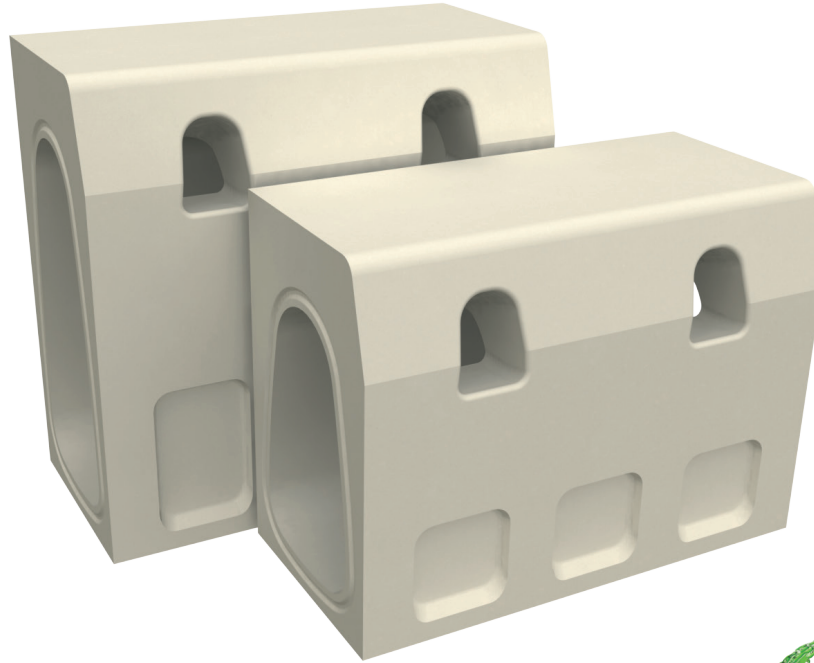







The ACO KerbDrain® E+ half battered range has a large hydraulic capacity to further compliment our existing KerbDrain® products. With a load classification E 600 this channel could be considered in areas subjected to large numbers of high speed heavy goods vehicles and large catchment areas eg distribution yards.

ACO KerbDrain® E+ is available in HB370E+ and HB480E+ along with following components:

- Access units
- Gully units
- Closing and outlet end caps



 HB Profile	 Kitemarked
370mm 480mm Unit depth	 CE and UKCA approved
 Hydraulic capacity	 0.5m units
1300m ² * HB370E+ catchment area 2400m ² * HB480E+ catchment area	 Gully unit for transitioning
 Load Class	* Example run based on 50m length laid level at 50mm/hr rainfall

ACO KerbDrain® HB370E+

Product Code	Description	Length [mm]	Width Overall [mm]	Depth [mm]	Invert Depth [mm]	Weight [kg]
HB370E+ half battered KerbDrain®						
4405	KerbDrain® HB370E+ channel 500mm E 600	500	240	370	342	48.5
4406	KerbDrain® HB370E+ access unit 500mm E 600	500	240	370	342	48.6

HB370E+ 500mm unit

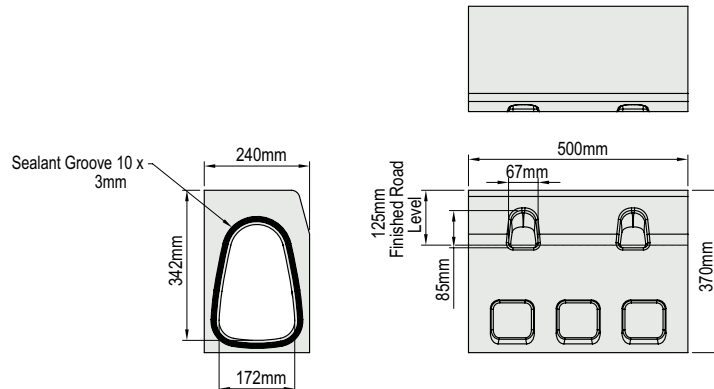

HB370E+ 500mm access unit

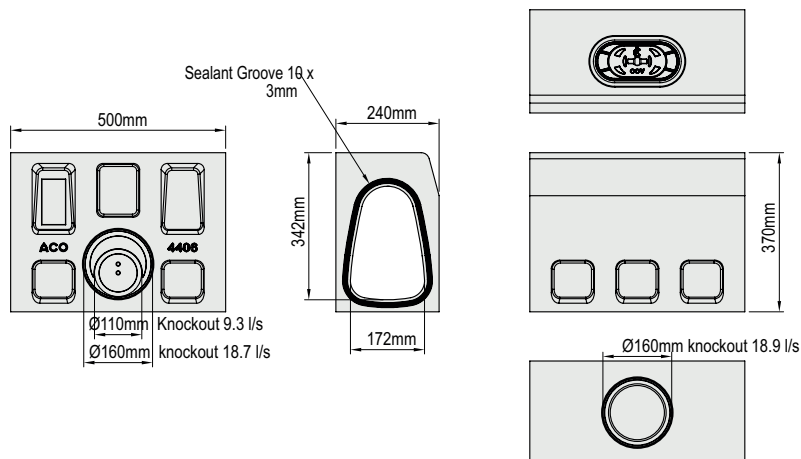
**HB370E+ end cap**

4402	KerbDrain® HB E+ universal closing end cap	50	240	480	N/A	12.2
4412	KerbDrain® HB370E+ LH outlet end cap	150	240	370	347	7.6
4411	KerbDrain® HB370E+ RH outlet end cap	150	240	370	347	7.6

HB370E+ universal closing end cap and LH outlet end cap

ACO KerbDrain® HB480E+

Product Code	Description	Length [mm]	Width Overall [mm]	Depth [mm]	Invert Depth [mm]	Weight [kg]
HB480E+ half battered KerbDrain®						
4400	KerbDrain® HB480E+ channel 500mm E 600	500	240	480	452	55.5
4401	KerbDrain® HB480E+ access unit 500mm E 600	500	240	480	452	55.7

HB480E+ 500mm unit

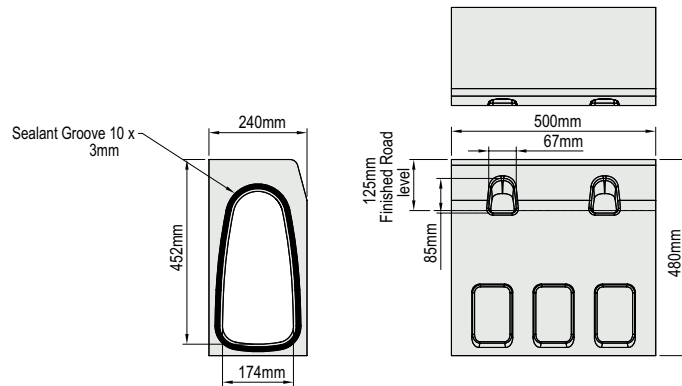

HB480E+ 500mm access unit

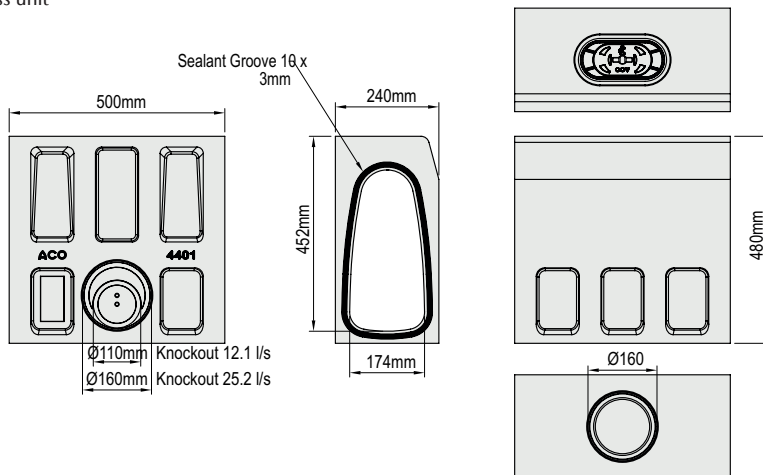

HB480E+ end cap

4402	KerbDrain® HBE+ universal closing end cap	50	240	480	N/A	12.2
4403	KerbDrain® HB480E+ LH outlet end cap	150	240	480	455	10.4
4404	KerbDrain® HB480E+ RH outlet end cap	150	240	480	455	10.4
32599	Polymer concrete repair kit	-	-	-	-	1

HB480E+ end cap

Maintenance of ACO KerbDrain®

Combined kerb drainage, ACO KerbDrain®, is maintained in very much the same way as grated or monocast systems and can be cleaned with the same jetting equipment.

Access is gained through an access unit or gullies. ACO KerbDrain® gullies provide the outfall connection to different systems and silt management, which is easily accessed by a ductile iron cover.

Equipment needed: ACO recommend using a recycler combination jetting unit with hydraulic winch, capable of producing pressure from 80 bar (1160 psi) to 150 bar (2176 psi).

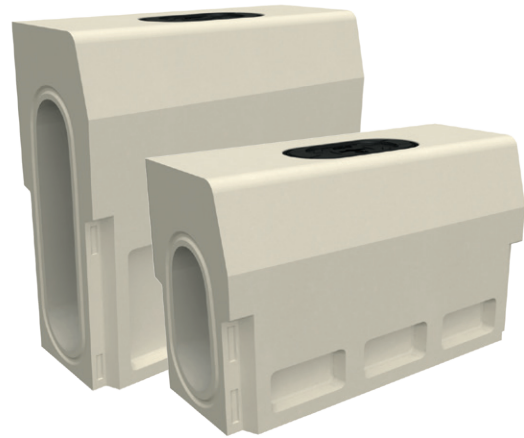

Method

- 1** Remove access unit top.
- 2** Position the jetting unit near the access unit or gully.
- 3** Attach a suitable jetting head and insert into access unit, towards the direction of travel. In this example a 1 inch (25mm) diameter tandem jetting head with forward and backward facing jets was used.
- 4** Introduce a 3-6 inch (75-150mm) suction hose into the adjacent gully/outlet.
- 5** This suction hose will remove the silt/detritus that the jetting hose flushes out.
- 6** Activate the suction hose and jetting hose. A suitable initial jetting pressure is 80 bar or 1160 psi.
- 7** As the jetting head travels up the length of the channel, place boards or tarpaulin over the channel openings to prevent the escape of water (spray back) and protect any vehicles or nearby property. Alternatively reduce the pressure to prevent spray back.
- 8** The jetting head will be propelled to the end of the channel or a determined length. When it reaches the end, increase the pressure to 150 bar (2176 psi).
- 9** Use a hydraulic winch to pull the jetting head backwards toward the access unit. The suction hose previously inserted in the gully/outlet will remove the water and detritus.
- 10** If a reduction of 'spray back' is required reduce the pressure to 80 bar (1160 psi). This pressure will still be sufficient to clean the channel.
- 11** When cleaning is completed, remove hoses and secure all gratings and covers.



Design support services

Surface water management system design can often be a complex task. Success in combining products and processes requires a thorough understanding of how these different elements work together.

The ACO Design Services Team is able to work closely with you through the entire design process to ensure accurate and cost-effective product selection is made.

Services we offer include (free and without obligation):

- Whole system design, from collection to the attenuation of surface water
- Hydraulic calculations and AutoCAD detailing
- Parts schedules
- Conduit files for MicroDrainage

ACO has embraced the concept of value engineering as an approach to on-site construction that saves both time and money.

ACO will review any design to minimise the total scheme and life cost of a proposal. The team can suggest the most appropriate range depending on your requirements.

Some ranges like MultiDrain or MonoDrain allow water to be contained and conveyed close to the surface, which accords with the principles advocated for Sustainable Drainage (SuDS Manual, 2015), by removing the need for pumping. Other ranges like Qmax allow attenuation – the storage of large volumes of water during storm events, reducing overall site costs.

For detailed designs using the ACO Hydraulic Design Software, please contact the ACO Water Management Design Services Team.

If manual calculations are preferred to using our QUAD software, hydraulic tables and instructions for manual calculations can be provided.

For design enquiries go to www.aco.co.uk/design-+-support-services





ACO BIM Models

BIM is the process of generating and managing data, and developing collaborative behaviours that will unlock new and more efficient ways of working at all stages of the project life-cycle.

These files will help contractors specify and optimise drainage systems in line with the overall benefits of BIM-

enabled working, including faster project delivery, reduced costs, reduced waste and greater project predictability.

Depending on the product range Civil3D, IFC or Revit files are available for download.

www.aco.co.uk/aco-bim-models

Further Learning

ACO Professional Development

ACO has recognised that knowledge transfer is fundamental in keeping up-to-date with the latest advancements in surface water management and has a unique training offer that can be accessed online, in-house or at the state-of-art training facility at the ACO Academy.

In Company

ACO offers face-to-face or by Teams professional development sessions. These are carefully designed to last up to 1 hour, so they can be undertaken across a lunch break.



A member of our team will contact you directly to discuss your requirements and will tailor the session to meet your needs.

Webinars

ACO has developed a series of webinars that will keep you up to date, bringing you technical expertise as well as more specific product information. Whatever your involvement from specification to installation, there will be a webinar to meet your needs and further your learning.



ACO Academy Days

ACO's training facility at its UK head office in Bedfordshire has a theatre-style facility that can hold up to 50 people as well as a number of breakout rooms for small groups.



Professional development training can be combined with more in-depth product training at the on-site learning zone.

Seminars

ACO is bringing the experts to you via our programme of regional events, and by sharing information from key influencers within the industry as well as more specific product information. ACO's seminar events will include opportunities to enhance existing knowledge as well as network and discuss thoughts and ideas with other delegates.



www.aco.co.uk/professional_development | email: ukprofessionaldevelopment@aco.co.uk



Case Studies

ACO has operated in the UK for over 30 years and in this time we have worked on ground breaking projects that have pushed the boundaries of surface water management. Our case studies provide bite sized information that counts towards your professional development and can provide inspiration for future projects.

www.aco.co.uk/case-studies



Colab

Colab is a collaboration of partnerships, bringing together CPD and self-certified content to ensure that knowledge is shared and accessible to the construction industry. Visit our content and CPD partner website: Colab to see more professional development content from partners such as ACO, FutureBuild, CIHT, The Edge, and CIWEM

www.colab-cpd.co.uk



askACO

train | design | support | care

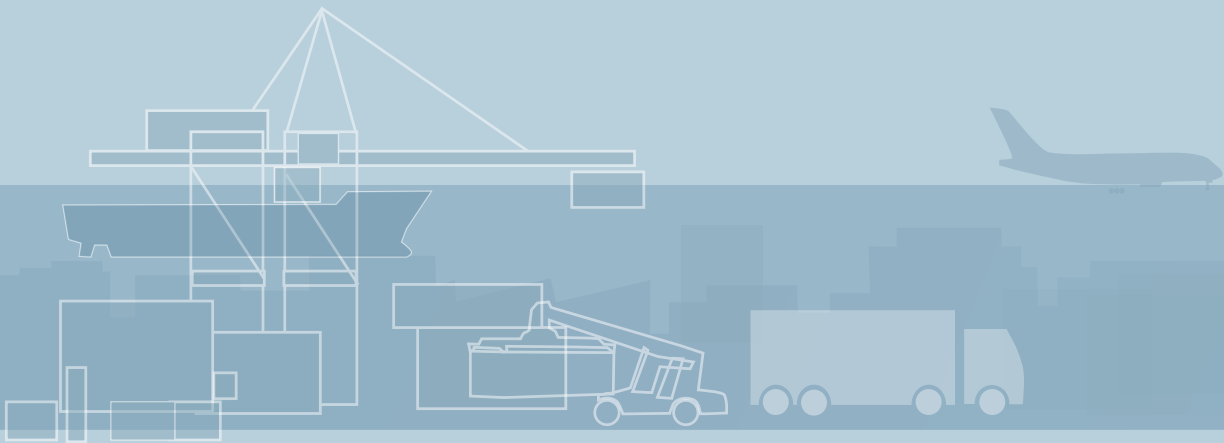

Every product from ACO Water Management supports the ACO WaterCycle



-
- [ACO Water Management](#)
[Civils + Infrastructure](#)
[House & Garden](#)
 - [ACO Building Drainage](#)
 - [ACO Access](#)
 - [ACO Sport](#)
 - [ACO Wildlife](#)
-

ACO Water Management

A division of ACO Technologies plc

ACO Business Park
Hitchin Road
Shefford
Bedfordshire
SG17 5TE

Tel: 01462 816666
Sales: customersupport@aco.co.uk
Project pricing: awmprojects@aco.co.uk
Technical: technical@aco.co.uk

www.aco.co.uk

ACO. we care for water

