



# ACO Qmax<sup>®</sup>

High capacity slot drainage system

Product Catalogue



## ACO Qmax®

ACO Qmax® combines traditional drainage functionality with attenuation capacity, allowing sites to be value engineered and reducing additional on-site storage needs.

The innovative pavement beam allows concrete and any rebar/cables to pass under the rail, making for an easy and robust installation. This versatile design has a range of hydraulic sizes, and inlet openings to suit pedestrian and Industrial locations

## ACO Qmax® 900



## ACO Qmax® 550



## ACO Qmax® 225





<b>Introduction to ACO Qmax®</b>	4
ACO Qmax® system layout	6
ACO Qmax® channel features overview	8
ACO Qmax® edge rails and components overview	10
Project case studies	12
ACO Qmax® system overview	15
<b>ACO Qmax® 150 system</b>	19
ACO Qmax® 150 system and components	20
<b>ACO Qmax® 225 system</b>	23
ACO Qmax® 225 system and components	24
<b>ACO Qmax® 350 system</b>	28
ACO Qmax® 350 system and components	29
<b>ACO Qmax® 225 and 350 access, outlet/inlet and silt chambers</b>	32
<b>ACO Qmax® 550 system</b>	35
ACO Qmax® 550 system and components	36
<b>ACO Qmax® 700 system</b>	40
ACO Qmax® 700 system and components	41
<b>ACO Qmax® 900 system</b>	45
ACO Qmax® 900 system and components	46
<b>ACO Qmax® 550, 700 and 900 access and silt chambers</b>	51
Controlling stormwater discharge	52
Design Software	54
Design Support Services	55
Channel installation detail	56
Access chamber installation detail	58
Chemical resistance chart	60
Specification clauses and certification	61

# ACO. we care for water

ACO is a Water-Tech company that protects water. Building on our global drainage expertise that protects people from water, we increasingly see our mission as also protecting water from people.

With the ACO WaterCycle, ACO provides systems that collect and channel, clean, retain and ultimately reuse water. In this way, ACO contributes to the preservation of clean groundwater as a vital resource, and makes a contribution to tomorrow's world. In its Agenda 2030, the UN global community set the improvement of water quality as one of 17 sustainable development goals.

Intelligent drainage systems from ACO increasingly use smart technology to ensure that rainwater and wastewater are drained, or temporarily stored. With innovative separation and filter technology, we prevent water contamination by pollutants such as fat and grease, fuels, heavy metals and microplastics.

Today, ACO goes one step further: we accept the challenge of reusing water, and thus establishing a resource-saving cycle. For all products and systems, ACO attaches great importance to durability, reusability and a low carbon footprint. The pursuit of sustainability is an ongoing process that we strive to meet every day.

The ACO Group is a global family business that is one of the world market leaders in the Water-Tech segment. Founded in Schleswig-Holstein in 1946, it operates as a transnational network in over 50 countries. Worldwide, ACO is characterised by a high level of decentralised ownership, and explicit regional market proximity.

[www.aco.com](http://www.aco.com)



**Holder**  
Iver and Hans-Julius Ahlmann



**Headquarters of the ACO Group**  
in Rendsburg/Büdelndorf





**5,200**

employees in more than 47 countries (Europe, North and South America, Asia, Australia, Africa)

**1 Billion**

Euro Sales in 2021

**37**

production sites in 18 countries



ACO Academy  
for practical training

## Water protection

## and rainwater management

### What is ACO Qmax®?

The ACO Qmax® system provides optimum surface water drainage and attenuation for a wide range of infrastructure, industrial, hard landscaped and other SuDS applications.



ACO Qmax® satisfies the demand for a versatile, high capacity slot drainage system for applications involving small to large catchment areas. For economical system design and installation, ACO Qmax® can cater for a wide range of applications to any load class.

ACO Qmax® is specifically designed to form an integral part of any modern, sustainable surface water management solution. The system maximises the hydraulic capacity available providing effective storage, attenuation, and eliminating carry over in stormwater conditions.

The ACO Qmax® system has six channel sizes ensuring greater system flexibility for engineers and designers to optimise scheme hydraulics. In recognition of its innovative design, ACO Qmax® has received many accolades including Construction Product of the Year 2006 and The Queen's Award for Enterprise: Innovation in 2006.

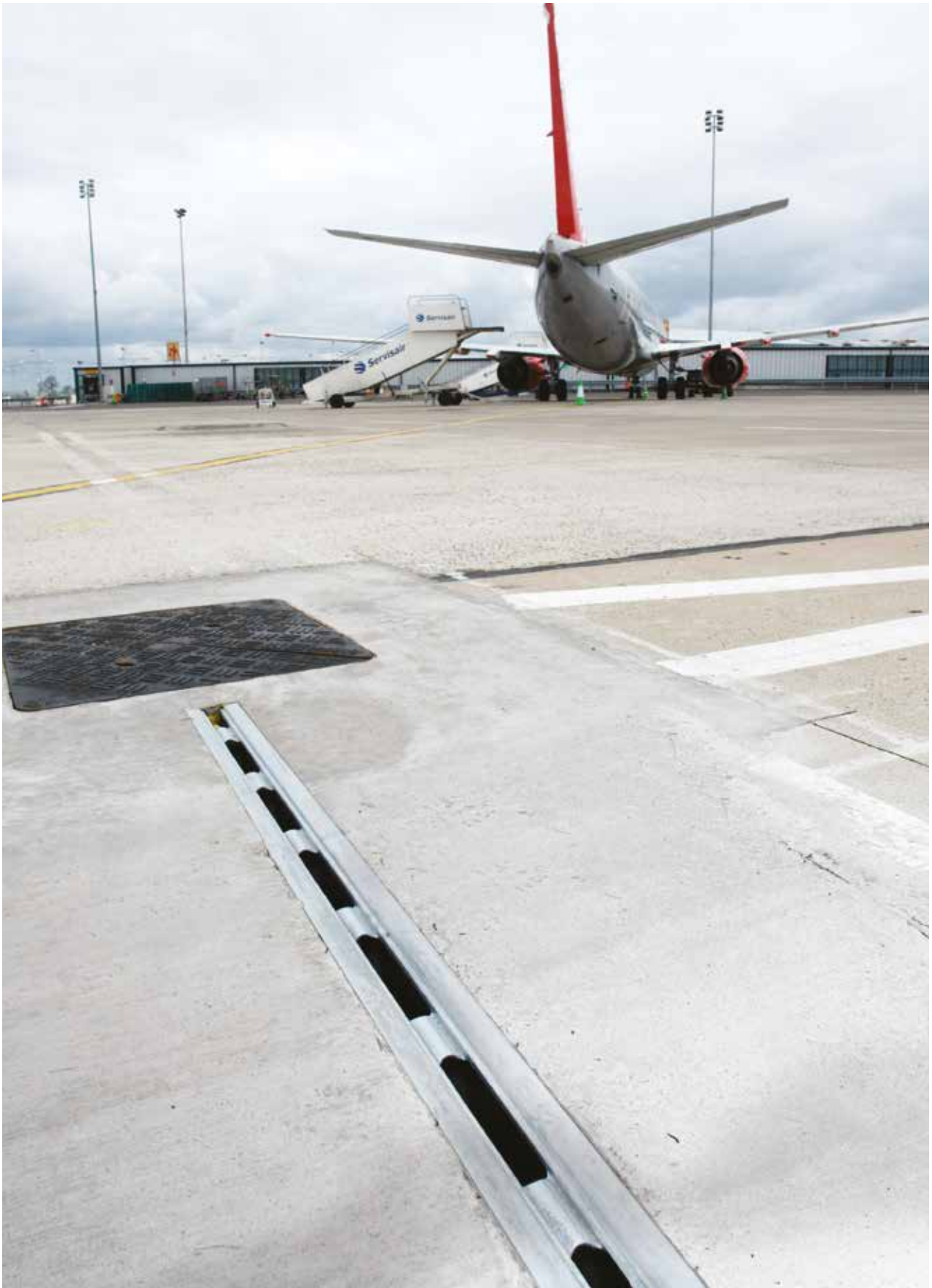

# Why choose ACO Qmax®?

## SuDS

ACO Qmax® provides many solutions as part of a SuDS system allowing engineers and designers to combine the benefits of both “Hard” and “Soft” SuDS in order to achieve the key elements of quality, quantity and amenity.

When combined with the ACO Q-Brake Vortex flow control, it can regulate and control stormwater before it discharges into the ongoing watercourses or drainage network.

## Discreet finish

To satisfy surface finishes and application requirements, ACO Qmax® is available with a range of discreet edge rail designs and materials.

ACO Qmax® channels come complete with either high quality ATec coated ductile iron, hot dipped galvanised steel, or composite plastic edge rails.

The edge rails are available in three different inlet slot designs: ACO Q-Flow, ACO Q-Guard, and for landscaped areas with block pavements or flags, the ACO Q-Slot galvanised steel edge rail provides a discreet, unobtrusive finish.



## System features

- Available in these sizes: 150, 225, 350, 550, 700 and 900
- The ACO Qmax® channel unit is 2m in length
- Simple connection between each channel run is provided by step and channel connectors
- Manufactured from Polyethylene (PE), including recycled material
- ACO Qmax® is easy to handle and quick to install
- Unique patented inlet design provides a continuous pavement beam feature over the line of the channel
- UKCA/CE marked and certified to BS EN1433:2002
- Supports all Load Classes up to and including F 900
- ATec coating on all the ductile iron edge rails

## System benefits

- Unobtrusive continuous slot drainage system
- Eliminates stormwater carry over
- Sealed system
- Meets environmental construction targets
- Improves onsite handling and installation rates
- Proven performance and durability
- Long service life in excess of 25 years





## Carbon Smart Certified

‘Carbon Smart’ signifies that an ACO product has achieved carbon neutrality. This is accomplished through changes in the manufacturing process, advancements in product technology, or by offsetting residual impacts that are beyond our control.

### Qmax Certification

ACO Qmax is the first product line in our range to earn the ‘Carbon Smart’ badge. This means that our Qmax drainage channel has been certified as Carbon Neutral. In other words, there are zero carbon emissions associated with its manufacture – a claim that encompasses both direct emissions (scope 1) and indirect emissions (scope 2).

This certification confirms that all emissions directly linked to the manufacture of the product comply with the standards set out in BS EN 15804.

#### How is Qmax Carbon Neutral?

**Green Energy:**  
We exclusively use renewable energy sources and green gas in our production process.

**Offsetting Credits:** direct operational and embedded carbon emissions in Qmax— from raw material extraction to manufacturing and transport— using accredited gold standard and VCS offsetting.

Find out more...



# ACO Qmax® system layout

The layout diagram below illustrates a selection of channels and components available within the ACO Qmax® range.

- 1** Edge rail protector for ductile iron edge rails
- 2** ACO Qmax® access / silt chamber with solid cover and frame
- 3** ACO Qmax® 700 chamber connector
- 4** ACO Qmax® 700 with ACO Q-Flow ductile iron edge rail
- 5** ACO Qmax® 550 to 700 step connector
- 6** Qmax® 550 with ACO Q-Guard ductile iron edge rail
- 7** ACO Qmax® 550 chamber connector
- 8** ACO Qmax® access / silt chamber with slotted cover and frame
- 9** ACO Qmax® 350 with ACO Q-Guard galvanised steel edge rail
- 10** ACO Qmax® access chamber with ACO Q-Slot recessed cover and frame
- 11** ACO Qmax® 225 with ACO Q-Slot galvanised steel edge rail
- 12** ACO Qmax® 225 end cap

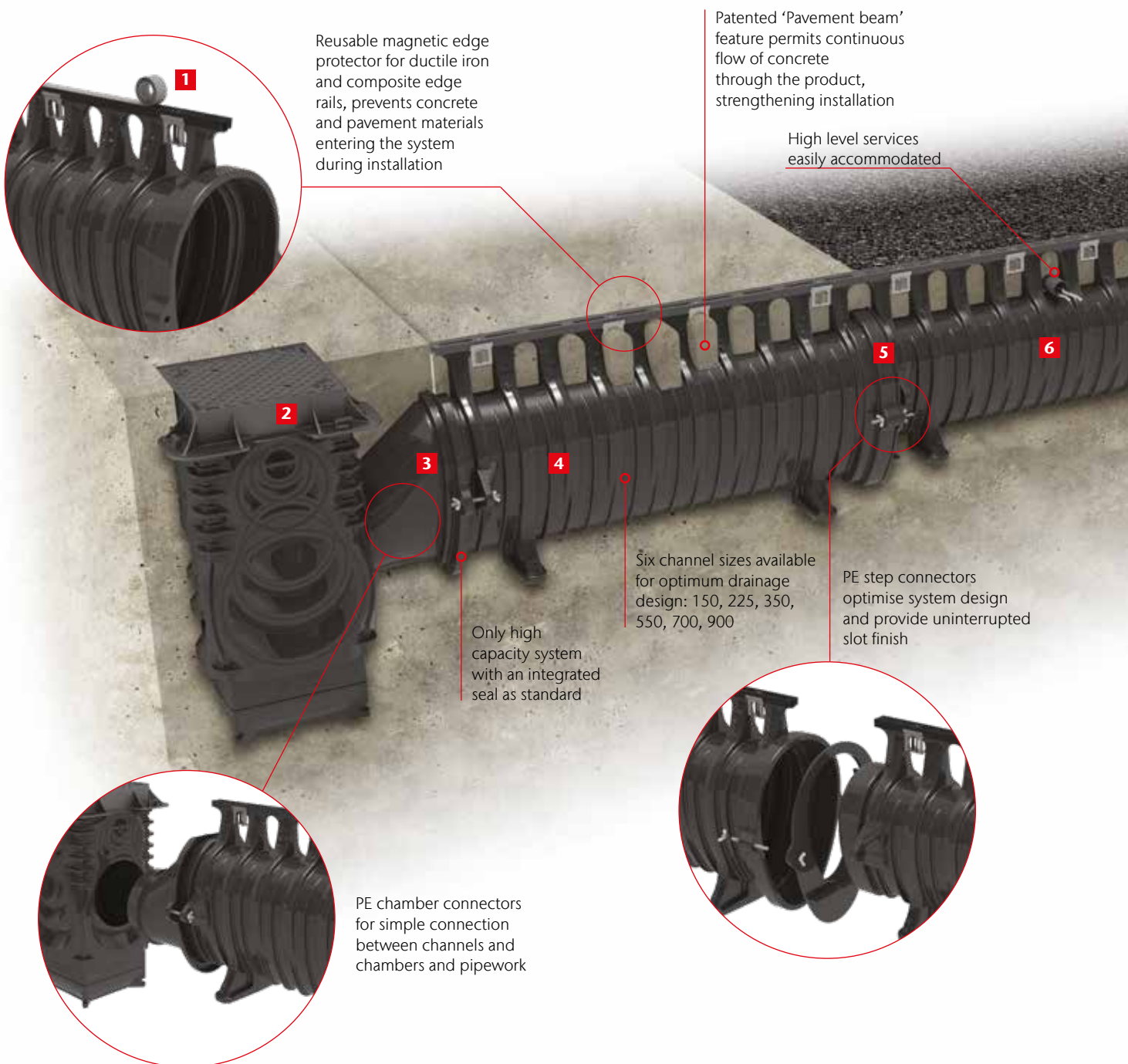

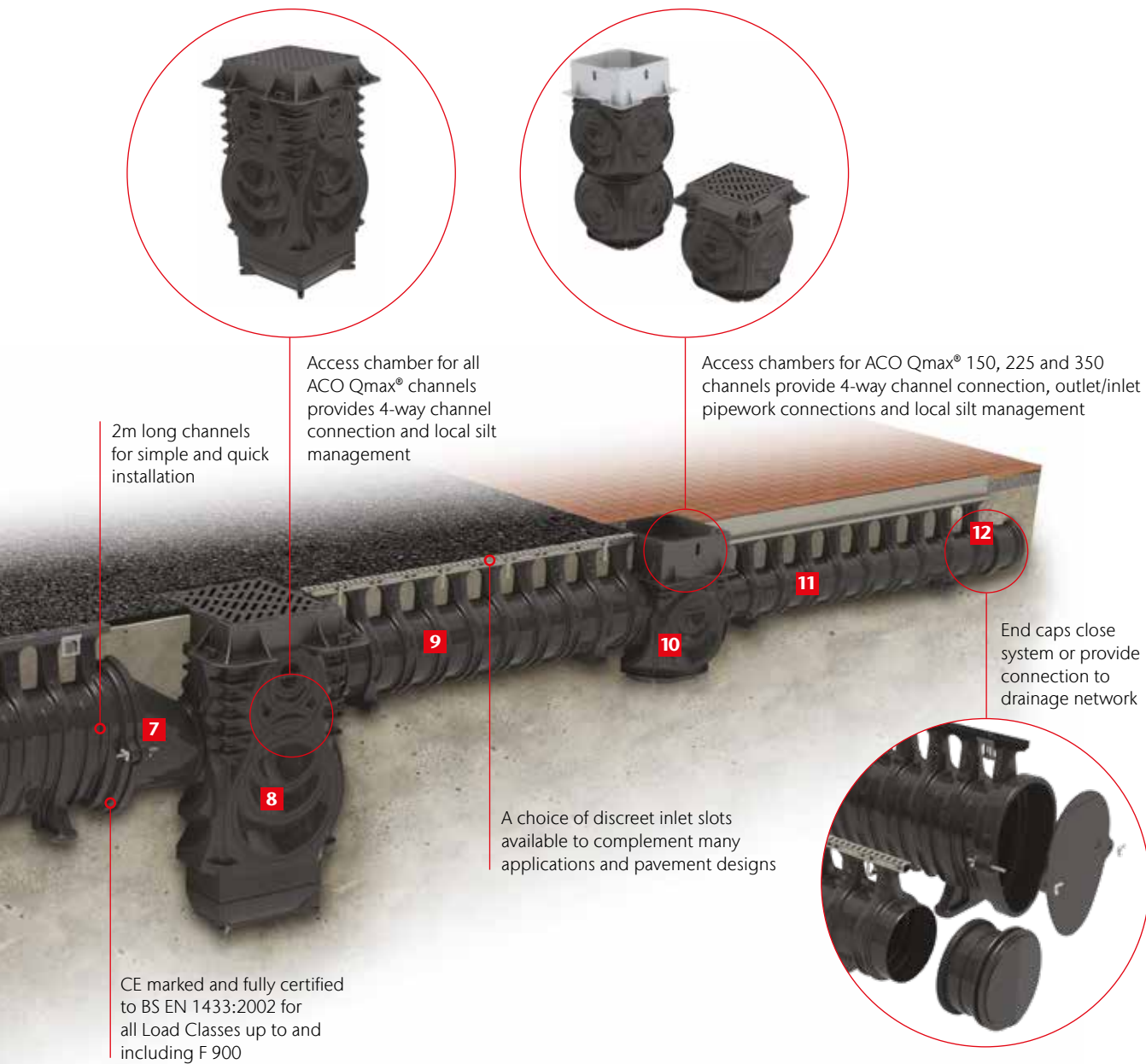

2m long channels for simple and quick installation

Access chamber for all ACO Qmax® channels provides 4-way channel connection and local silt management

Access chambers for ACO Qmax® 150, 225 and 350 channels provide 4-way channel connection, outlet/inlet pipework connections and local silt management

End caps close system or provide connection to drainage network

A choice of discreet inlet slots available to complement many applications and pavement designs

CE marked and fully certified to BS EN 1433:2002 for all Load Classes up to and including F 900

**Controlling stormwater discharge**

If a controlled rate discharge is required, ACO Qmax® can be used in conjunction with the ACO Q-Brake Vortex flow control unit to regulate stormwater flows. ACO Q-Brake Vortex provides superior hydraulic performance in comparison to traditional flow control systems and permits more flow at lower heads, reducing storage volume requirements and lowering cost. For more information on ACO Q-Brake Vortex see page 64 or go to [www.aco.co.uk/products/q-brake-vortex](http://www.aco.co.uk/products/q-brake-vortex)



# ACO Qmax® channel features overview

Patented 'Pavement beam' feature permits continuous flow of concrete through the product, for strong and cost effective installation

Simple push fit channel connection detail for easy edge rail alignment

ACO Qmax® 550, 700 and 900 channels are provided with wingnut connection

Integrated channel seal for quick and easy watertight connections\*

UKCA/CE marked and fully certified to BS EN 1433:2002 for all Load Classes up to and including F 900

Female connection detail

ACO Qmax® channels are available as standard with three different edge rail details for specific applications



## Available channel sizes:

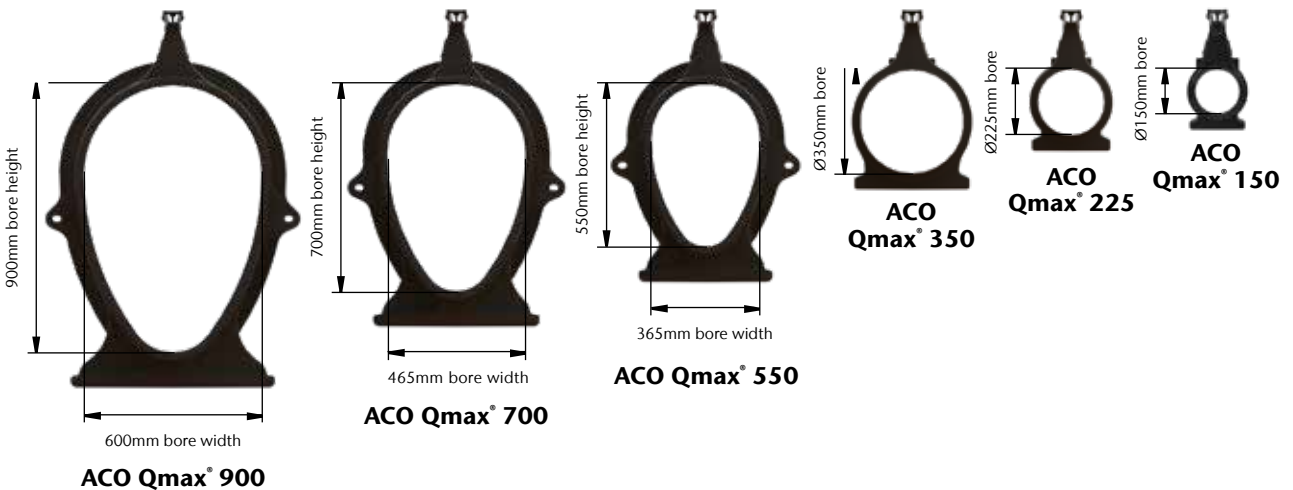





## Load Classes



**A 15**  
Pedestrian, cycleways, minimally trafficked areas (light domestic vehicles only).



**B 125**  
Pedestrian precincts, light vehicles, private car parks and drives.



**C 250**  
Parking areas, service stations (cars) and slow-moving light commercial vehicles.



**D 400**  
Public highways, parking areas for all types of vehicles, distribution yards.



**E 600**  
Industrial areas, heavy wheel loads, slow-moving HGV's and forklifts, service stations.



**F 900**  
Airport runways, very heavy industrial and military installations, service yards and lorry parks.

\*ACO Qmax® channels are tested to confirm compliance with the watertightness requirements of BS EN 1433 when filled with water to the top of the channel bore. See watertightness note on page 22 for more information.

# Surface design detail

## Bringing aesthetic choices to high capacity slot drainage

Style, aesthetics, performance and reliability are all important factors when specifying surface water management systems. Globally recognised as the number one choice in managing surface water, ACO provide designers with the widest range of channel and grating

styles to choose from. By using a range of different design options including form, texture, material and colour, ACO's grating and channel styles can be used to complement or enhance many landscape designs.



## Multiple applications with Qmax edge rails

The discreet edge rails of Qmax mask the large capacity drainage underneath, and with a choice of material and colour options Qmax can be further blended into the landscape or used as a landscape feature.

Depending on the application, Designers, Planners and Architects can choose from rails in ductile iron, hot dipped galvanised steel or the composite material, which comes in black.

With 3 designs and 3 materials, from 9mm to 26mm slot widths, these rails are compatible with all Qmax channels.



**Q-Flow Ductile Iron**  
Finish: ATeC coated ductile iron  
Slot Width: 26mm

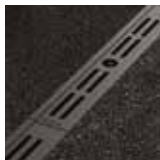

**Q-Guard Ductile Iron**  
Finish: ATeC coated ductile iron  
Slot Width: 8mm twin slot



**Q-Flow Composite Black**  
Finish: Composite plastic  
Slot Width: 25mm



**Q-Slot Steel**  
Finish: Hot dipped galvanised steel  
Slot Width: 10mm discreet slot



**Q-Guard Composite Black**  
Finish: Composite plastic  
Slot Width: 9mm



**Q-Guard Steel**  
Finish: Hot dipped galvanised steel  
Slot Width: 10mm



**Q-Flow Steel**  
Finish: Hot dipped galvanised steel  
Slot Width: 26mm

## Urban Surface Design

### Designing surface water run-off in urban environments



#### Designing Lines

The term 'line' typically relates to structures within a landscape - the edges of footpaths or flower beds and how they link with open space; in domestic environments it references things like the perimeter of a patio or deck. The long 2 metre ACO Qmax® channel lines can be utilised to critically influence the flow of any landscape, not least in the urban environment.

For more information on Urban surface design go to...  
[www.aco.co.uk/Urban-Surface-Design](http://www.aco.co.uk/Urban-Surface-Design)

#### Technical Performance

All ACO channel systems interface directly with the load demands from traffic, and they also have to meet hydraulic demands – with the inlet needing to be capable of coping with varying levels of water flow. All ACO channels have clearly defined hydraulic capacity and have been developed using design formulae for calculating the hydraulic flow capacity of drainage channels. Even discreet slot channels can accommodate high capacity drainage underneath.

#### Scale

In urban design, scale refers to the size relationship between elements within structures and the surrounding 'space'. Frequently it is also the surface elements within the 'space' that contribute to a visual perspective. Consequently it is important to make size choices that are suitable for the setting and the scale of the design. The largest ACO Qmax® has the highest capacity in the range and might be expected to have a consequentially large profile at the surface, this is not the case as Qmax surface options include a variety of discreet slot inlets.



A clever, yet easy to use software program that visualises how our range of grating designs could enhance your project.

To make specification easier, the software will suggest our most suitable ranges based on the project requirements. You can then select from the available options and visualise how these may look in different surface finishes. Once a choice is made, a simple, yet detailed specification sheet provides full product information.



To launch the visualiser scan the QR code or visit  
[www.aco.co.uk/gratingvisualiser](http://www.aco.co.uk/gratingvisualiser)



## A range of solutions with ACO Qmax®

Since its launch, the many benefits of ACO Qmax® have helped architects, engineers and contractors realise some of the country's most ambitious, groundbreaking and high profile projects.



### Minimal disruption

Keeping disruption to a minimum was essential as Belfast International Airport undertook a major extension and refurbishment of its aircraft handling aprons. ACO Water Management's Design Services conducted trials that proved to the Belfast team that ACO Qmax® set in a polycarbonate fibre reinforced concrete mix would not only meet the specified cure time but also deliver Load Class F900 performance. Four sizes of ACO Qmax® have been installed across the project forming the principal part of a wider SuDS system handling surface water from all the areas of hardstanding.



### Value and Versatility

The transformation of the former quarry site into five state-of-the-art logistics centres ranging from 50,000 to 700,000 sq ft required extensive earthworks and remediation before superstructure works could commence. By exploiting the handling and Value Engineering benefits of Qmax, Winvic were able to complete the critical groundworks phases within extremely tight schedules, using the Load Class versatility of ACO Qmax® to provide surface water management in all the trafficked areas including trailer handling yards, access roads and car parks.





## Total SuDS solution

The refurbishment of J & J Stanley's recycling centre has benefited from a SuDS scheme created using products from every process within ACO's System Chain - Collect, Clean, Hold, Reuse. By integrating the high attenuating capacity of ACO Qmax® with an ACO Q-Ceptor, StormTank and a Q-Brake Vortex, the scheme's overall performance has been designed to balance the operating conditions of the facility with the discharge limits for the site – a Value Engineering exercise that has reduced total cost and installation time and minimised ongoing maintenance requirements.



## Self contained SuDS

All run-off generated from the new eight acres of hardstanding created for Mansfield Brick's new manufacturing facility is collected, cleaned and returned safely to ground within the curtilage of the site. Meeting the project planning requirements, no connection to the main sewer network has been made. By utilising the high attenuating capacity of over 1000 metres of ACO Qmax®, consulting engineers MHI were able to avoid having to provide additional underground stormwater storage – a benefit that greatly simplified the overall design and significantly reduced installation time and costs.

# A range of solutions with ACO Qmax®



## Managing for exceedance

ACO's Qmax® 225 was selected for use in the car parking areas alongside a permeable paving option. Water can be stored at source within the product, allowing for a controlled discharge of water to surrounding drainage networks, to manage heavy downpours and exceedance. This solution supported John Lewis' 'Responsible Development Framework' which is concerned with future proofing Waitrose against the impacts of climate change.



## Discrete drainage in an historic site

The Cutty Sark Gardens, situated in historic Greenwich, were redeveloped to provide a versatile public space which can be used for special events and also accommodate the large numbers of visitors to the Cutty Sark ship.

ACO Qmax® was chosen to provide effective, discreet drainage in keeping with the traditional design of this historic public area. Q-Slot edge rails were used within the terraces and pedestrian areas of the tidal square. The 10mm inlet edge rails were installed within the natural breaks between the granite pavements, forming a virtually invisible solution. The narrow inlets for this system not only create an aesthetically pleasing, unbroken landscape in the area, they also provide a practical solution for heavy pedestrian traffic with no large gaps where heels can be caught.





## Award-winning surf complex makes waves

The Wave, required a very specific level of water attenuation. ACO Qmax® was chosen because of its slimline design both above and below ground, which makes installation significantly more straightforward.

SuDS are an increasingly important factor in the design of any project, and with The Wave situated on a Greenfield site, sustainable collection and removal of rainwater was even more vital. This necessitated an innovative approach to water management.

One of the key factors is to prevent contaminants from entering the nearby lake. This required a robust drainage solution all along the perimeter of the water, which could offer the hydraulic capacity to ensure no contaminants entered the lake.

## Designing the scheme

ACO has been a pioneer of 'Value Engineering' – a revolutionary approach to design and construction. Through ACO Water Management's Design Services Team, any proposal can be Value Engineered to identify how its performance can be optimised with minimal use of materials. Powerful CAD systems produce full hydraulic calculations and installation schedules that enable all on-site work to be completed efficiently. It is a unique, comprehensive service that is provided free of charge. ACO Qmax® has played a key role in realising the benefits of Value Engineering. Its high carrying capacity, ability to

attenuate stormwater flows, ease of installation, and design versatility allow extensive conventional drainage networks to be greatly simplified, significantly reducing installation and whole lifetime costs.

### **ACO Water Management Design Services Team**

Telephone: 01462 816666

e-mail: [technical@aco.co.uk](mailto:technical@aco.co.uk)

# ACO QuAD Hydraulic Design Software

Try our free design tool

The free-to-use ACO QuAD Hydraulic Design software has unprecedented levels of choice and flexibility built-in, to enable the efficient and accurate hydraulic design of any surface water management scheme.





The hydraulic engine has been robustly tested and is the tool used by ACO's own internal Design Services Team in modelling surface water solutions for customers.

ACO QuAD Hydraulic Design software uses differential equations for spatially varied flow that online alternative solutions cannot accurately match. For example the Manning's equation for steady uniform flow does not work with level channels and is grossly inaccurate on shallow gradients.

Here are some of the features it includes:

- Powerful project-based software
- Create catchment models that are fully editable
- PDF summary document output
- Cloud based – All designs are stored securely on our server against your login
- Integrated rainfall data for the whole of the UK

## QuAD Features Overview

### Cloud based

The software means increased efficiency providing design resources you need when you need it, allowing you to deploy the same design capability consistently, with the same consistency in results every time.



### Application

Application selection ensure designers are able to get quick and accurate guidance in selection of the most suitable products based on the type of application the catchment is to cater for.



### Flexible catchment design

QuAD is designed to support designers in the creation of catchment areas. Supplementary catchment areas can easily be added upstream and downstream of any previously designed channel run.



### Rainfall assist

Rainfall intensity by location matters in design. QuAD provides a site locator map enabling the most accurate intensity to be input.



### Product + value optimiser

Optimising the specific channel runs can be done with the optimiser feature selecting the smallest product suitable. Excavation and concrete requirements are also provided.



### Resilience assessment

By inputting anticipated sedimentation rates and sedimentation density the QuAD software enables the designer to test their suggested maintenance schedules.



### Attenuation assessments

Calculate the attenuation required for the project and compare it with the storage available in the channel design. Attenuation volume is presented along with suitable options for storage.



### Secure scheme filing

All designs created by registered users are stored on a secure server and are password protected. Past projects are easily retrieved from the personalised menu.



### Flexible download format

Output can be generated for all or parts of the project and can be generated in pdf or CSV formats.



### Fully supported

There is support available either through a query submission or through self-help made possible by the comprehensive Knowledge database.



# Channel installation detail

## Load class

Installation recommendations shown are ACO minimum recommendations for BS EN 1433:2002 load class requirements.

## Ground conditions

The long term performance of a channel installation to sustain vertical and lateral loads depends upon A) ground conditions B) stability of the adjacent pavement and C) a durable concrete bed and surround. The recommended installation detail may require the minimum dimensions to be revised to achieve site specific load class requirements (referred to in 1.0 above).

## Cutting and jointing

The 2000mm long channels may be cut to a shorter length of 400mm, 1000mm and 1400mm. Where possible 90° joints and T's should be formed so that rails do not have to be cut utilising ACO Qmax access/inlet/outlet/silt chambers. Angles can be formed by connecting them using proprietary pipework attached to ACO inlet/outlet endcaps. For further details please contact ACO Technical Support Team. Where requested ACO can custom manufacture special connections to order.

## Isolation joints

The channel must be isolated from the surrounding environment. An isolation joint must be positioned up to 1500mm from the channel wall. Any dowel bars must be located no nearer than 150mm from the channel wall. Other isolation joints in surrounding slab must be continued through the channel. Additional crack control may be required to comply with specifier requirements.

## Concrete surround and reinforcement

Ensure that the channels do not float while pouring the concrete. To prevent flotation or distortion of the 550, 700 and 900 when using high workability concrete, pour concrete in several lifts (e.g. 1 to the line on the side of the channel, 2 to the crown of the channel and 3 to the finished levels). Concrete lifts to 1 and 2 to be 50mm maximum slump (consistance class S1).

The reinforcement required in the concrete surround varies with the installation group (load class) and channel size. For a load class D 400, E 600 & F 900, it may be necessary to reinforce over, under and to the sides of the unit (as indicated).

The combined depth of the asphalt pavement must not exceed the Y2 and Y3 dimensions given in the table. Ensure the edge rail anchors are well embedded into the concrete.

## Temporary installation

A channel installation is not complete until the final surfacing is laid. In any temporary condition, i.e. with the channel walls projecting above adjacent ground, site traffic should not cross channels. Loose boards, stone fill or cover plates will not protect the channel walls or grating. A temporary channel crossing should be formed by raising the ground level locally, to 3 - 6mm above top of edge rail, either side of a channel for a distance of 750 to 1000mm say, to form ramps. Note that the channel load class should be adequate to carry the site traffic.

## Block pavements

The channel must be supported laterally. Blocks laid directly against a channel must be laid as a soldier course and restrained from movement by bedding securely on the concrete haunch e.g. by using a polymer modified mortar for bed and perpendicular joints (e.g. RONAFIX mortar mix C or similar). Blocks or slabs bedded on sand remote from the channel should be set at a higher level to compensate for possible settlement of the paving in service.

## Channel protection

Avoid contact between compaction equipment and top of ACO channel edge rail. The installer must ensure that the finished surface level lies above the top of the edge rail (by at least 3-6mm). Covering or protecting the rails, before concreting the haunch or laying blocks, removes the time and cost associated with cleaning the channel and grating of cement material and embedded stones. During site work ensure that the plastic protective strip (supplied with the galvanised steel edge rails) or the ductile iron edge rail protector (supplied separately) is not damaged or displaced, in order to prevent debris entering the channel during construction. Ensure the edge rail anchors are well embedded into the concrete.

## Watertight installation to BS EN 1433:2002

Where ACO Qmax channels are to be installed with watertight joints, the seal between channel units must be checked for cleanliness and then smeared with lubricant jelly such as proprietary pipe joining lubricant. Guidance on the preparation should be sought from the lubricant manufacturer.

## ACO Qmax® 150, 225 and 350 channel units

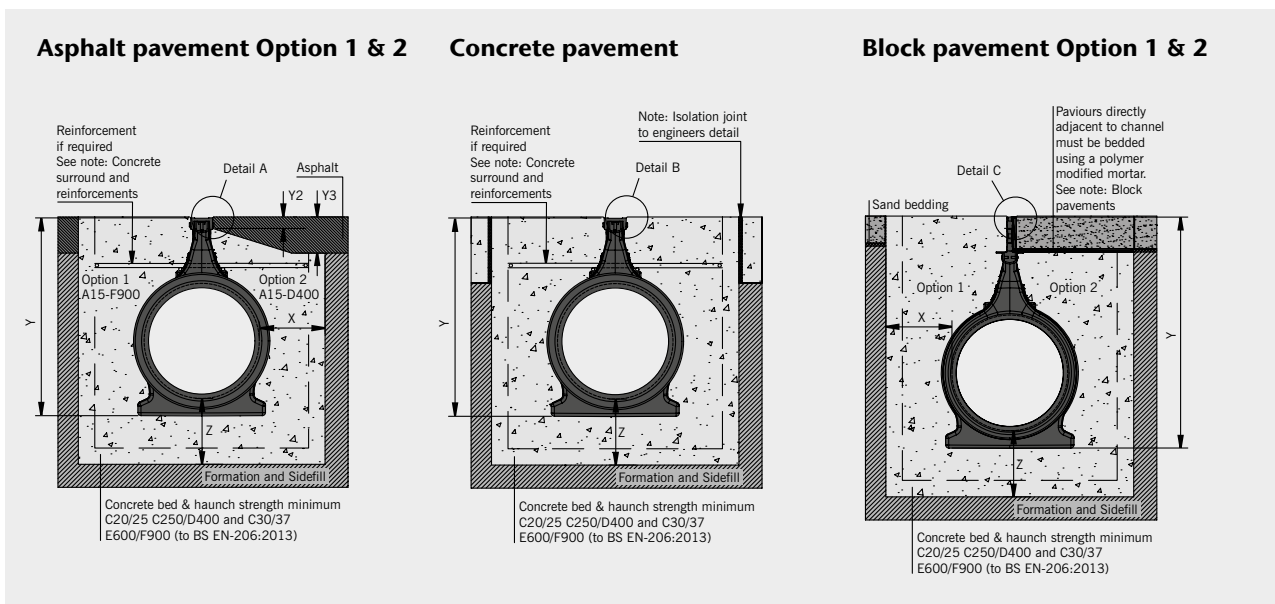

### Load Class concrete requirements

Load Class	C 250	D 400	E 600	F 900
Concrete class:	C20/25	C20/25	C20/25	C20/25

#### ACO Qmax® 150

X	100	100	150	200
Y	Full Channel Height (less Y2 where applicable)			
Z	100	100	150	200
Y2*	35 max	35 max	N/A	N/A
Y3*	110 max	110 max	N/A	N/A
Reinforcement	No	No	No	No

#### ACO Qmax® 225

X	150	150	150	200
Y	Full Channel Height (less Y2 where applicable)			
Z	150	150	150	200
Y2*	35 max	35 max	N/A	N/A
Y3*	110 max	110 max	N/A	N/A
Reinforcement	No	No	No	Yes

#### ACO Qmax® 350

X	150	150	150	200
Y	Full Channel Height (less Y2 where applicable)			
Z	150	150	150	200
Y2*	35 max	35 max	N/A	N/A
Y3*	110 max	110 max	N/A	N/A
Reinforcement	No	No	No	Yes

Load Class	C 250	D 400	E 600	F 900
Concrete class:	C20/25	C20/25	C20/25	C20/25

#### ACO Qmax® 550

X	150	150	200	200
Y	Full Channel Height (less Y2 where applicable)			
Z	150	150	200	200
Y2*	35 max	35 max	N/A	N/A
Y3*	110 max	110 max	N/A	N/A
Reinforcement	No	No	No	Yes
Dimension D	265	265	265	265

#### ACO Qmax® 700

X	150	150	200	200
Y	Full Channel Height (less Y2 where applicable)			
Z	150	150	200	200
Y2*	35 max	35 max	N/A	N/A
Y3*	110 max	110 max	N/A	N/A
Reinforcement	No	No	Yes	Yes
Dimension D	290	290	290	290

#### ACO Qmax® 900

X	200	200	200	200
Y	Full Channel Height (less Y2 where applicable)			
Z	200	200	200	200
Y2*	35 max	35 max	N/A	N/A
Y3*	110 max	110 max	N/A	N/A
Reinforcement	No	Yes	Yes	Yes
Dimension D	315	315	315	315

All dimensions are shown in mm. \*Check suitability of rail for asphalt installation.

ACO Qmax channels are tested to conform compliance with the watertightness requirements of BS EN 1433 when filled with water to the top of the channel bore (below the inlet arches). Installation must be in accordance with ACO's recommendations and the recommendations of the lubricant manufacturer. It is envisaged that the channel joints would not be subject to movement, but any movement of the joint might compromise the watertightness.

**Note:** Galvanised steel and iron products have good corrosion resistance to concrete and mortar products but may experience corrosion if high chloride and/or sulphate content is present. Use only good quality concrete and consider using corrosion inhibitors where necessary. The use of protective coatings, such as paint, can minimise the risk of corrosion.

#### Detail A

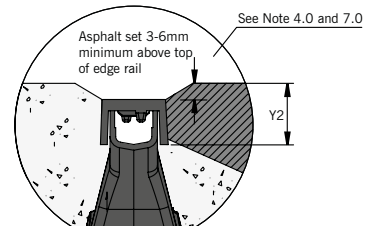

#### Detail B

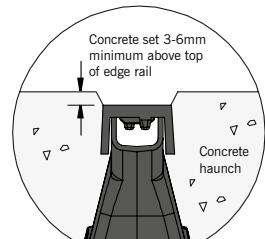

#### Detail C

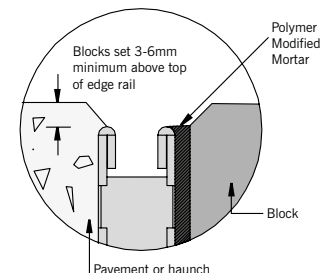

### ACO Qmax® 550, 700 and 900 channel units

#### Asphalt pavement Option 1 & 2

Option 1 Load Class A 15 - F 900  
Option 2 Load Class A 15 - D 400

Reinforcement if required See note: Concrete surround and reinforcements

Concrete class See notes: Concrete surround and reinforcements and load class concrete requirements

Concrete lift dimensions See note: Load class concrete requirements

#### Concrete pavement

Isolation joint to engineer detail See note: Isolation joints

Reinforcement if required See note: Concrete surround and reinforcements

Concrete class See notes: Concrete surround and reinforcements and load class concrete requirements

Concrete lift dimensions See note: Load class concrete requirements

#### Block paving

Reinforcement if required See note: Concrete surround and reinforcements

See note: Block pavements

Concrete class See notes: Concrete surround and reinforcements and load class concrete requirements

# Access chamber installation detail

## Chamber preparation

Remove the appropriate ACO Qmax® access chamber circular connection panel(s) with padsaw or similar.

For the access, outlet/inlet, silt chamber, remove the base of the upper unit and top of the lower unit.

## Excavation

Excavate including for the concrete bed and surround. Allowance must be made for the access chamber, cover and frame.

## Concrete base

Backfill around the ACO Qmax® access chamber with concrete, for class see table 10.0 given in tables on page 23, to fix the unit in place. Base concrete level should not interfere with channel connection. Ensure the chamber does not float or move.

## Channel connection

Connect the channels: For the ACO Qmax® 150, 225 and 350 female channel connections the seal must be removed to connect to the ACO Qmax® Access Chamber. Male channels can connect directly. For connection of ACO Qmax® 550, 700 and 900 channels to ACO Qmax® access chambers an access chamber connector must be used. The ACO Qmax® access chamber connector must be cut, and the pipe connection detail removed, to enable connection to the ACO Qmax® access chamber.

## Concrete surround

Install and backfill access chamber and channels with concrete as per ACO installation detail. Remove ACO Qmax® access chamber top panel prior to installation of frame and cover.

The minimum class of concrete is given in table 10.0 given in tables on page 23 depending on channel size and load class required with the chamber, subject to the client engineer's specification.

## Chamber design and reinforcement

The customer should ensure that the minimum dimensions shown are suitable for the existing ground conditions. The structural design/reinforcement of the concrete surround is to be determined by the client. Engineering advice may be necessary.

The reinforcement required in the chamber construction varies with the installation group (load class). Engineering advice should be sought.

## Joints

The detailing of joints is to be determined by the engineer in conjunction with the detailing of the pavement. A longitudinal expansion joint is typically formed down each side of the chamber (as indicated). Where the pavement is asphalt or block paving (with no concrete slab), then expansion joints may not be necessary. Engineering advice should be sought.

**ACO Qmax® 150, 225 & 350 access chamber with slotted cover and frame**

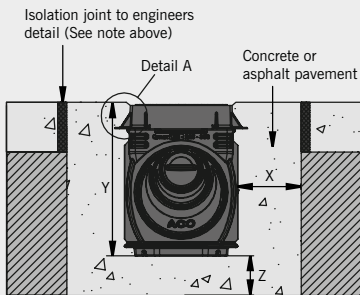

**ACO Qmax® 150, 225 & 350 access, outlet/inlet chamber with slotted cover and frame**

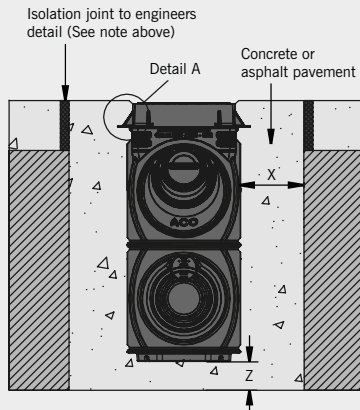

**ACO Qmax® 150, 225 & 350 access, outlet/inlet and silt chamber with slotted cover and frame**

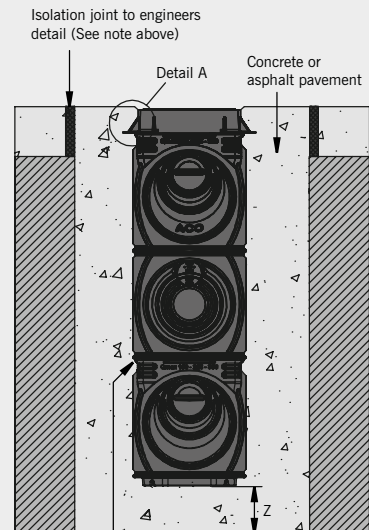

Prior to installation, remove base and top panels at this level



## Installation guidance

ACO can give guidance with respect to the most suitable methods of installation for the Qmax® range. ACO Qmax® should be installed using acceptable levels of workmanship and according to the National Code of Practice (UK: BS 8000: Part 14:1989) in keeping with BS EN 1433:2002 (Drainage channels for vehicular and pedestrian areas).

Detailed installation statements and methodologies will vary for all sites as each will have different aspects deserving particular consideration, consequently the relevant approvals should be sought from the consulting engineer and/or the installer.

## Offloading, handling and storage instructions

In all operations, do not stack product on spigot (Male) end.

### ACO Qmax® 150, 225 and 350 Channels

Offload channels from delivery vehicle using forks. Do not throw channels off the vehicle. Products may have moved in transit. Ensure that stack is stable before removing pallet wrap. To avoid product falling during unpacking, ACO recommend that this is a 2 man job. Always lift stack via pallet. Do not lift from any part of channel.

### ACO Qmax® 550, 700 and 900 Channels

Offload channels from delivery vehicle using long forks or slings as appropriate. Do not throw channels off the vehicle. If craned, do not support from waterway inlet – use arches under the inlet slots. ACO Qmax® may be stored vertically, single stacked on socket (female) end or horizontally in a single layer.

## Storage instructions

ACO advises that products are stored in their original packaging until required to ensure protection of the product and to aid manoeuvre on site. Pallets of product must not be stacked on site to prevent damage and must be stored in a single layer only. All unwrapped products must be stored horizontally in a single layer.

When long term storage is envisaged (Greater than 6 weeks), the ACO Qmax® channels must be protected from direct sunlight, if protection cannot be provided, consideration must be given to the effects of daily exposure to direct sunlight. Protect from prolonged sub-zero temperatures. Do not allow heavy materials to be stacked on or against channels.

### ACO Qmax® 150, 225 & 350 access chamber with slotted Q-Slot recessed cover

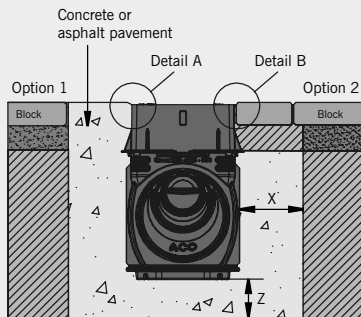

### ACO Qmax® 150, 225 & 350 access, outlet/inlet and silt chamber with slotted Q-Slot recessed cover and frame

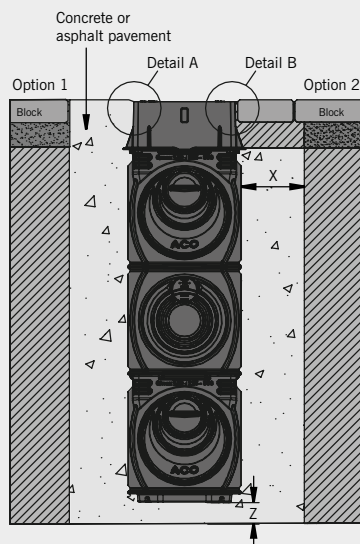

### ACO Qmax® 550, 700 & 900 access chamber with D 400 slotted/solid cover and frame oval to round connection detail

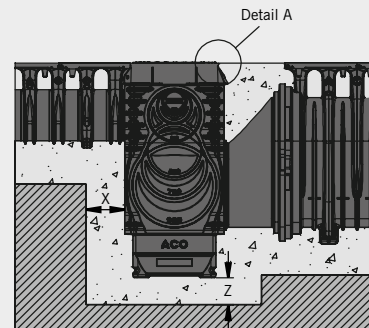

### ACO Qmax® 150, 225 & 350 access, outlet/inlet chamber with D 400 Q-Slot recessed cover and frame

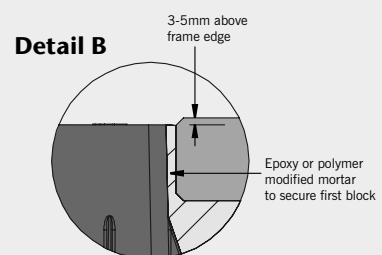
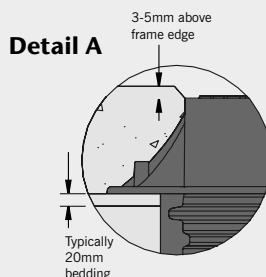
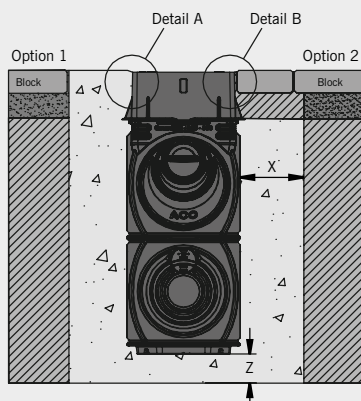



# ACO Qmax® system overview

## Making the right product selection

ACO Qmax® is available in six channel sizes: 150, 225, 350, 550, 700 and 900.

To summarise the available options, the product selector below displays key features for each of the profiles and unit depths available.

Once product selection has been made based on the features required, the table will direct you to the appropriate page.

### ACO Qmax® is:

- Available in six channel sizes
- Supplied in 2m lengths
- Manufactured from tough, highly corrosion resistant PE
- CE and UKCA marked and fully certified to BS EN 1433:2002, A 15 – F 900



	ACO Qmax® 150	ACO Qmax® 225	ACO Qmax® 350
	Page 31	Page 35	Page 40
			
UNIT	<b>150</b>	<b>225</b>	<b>350</b>
HYDRAULIC CAPACITY			
CATCHMENT AREA*	<b>390m<sup>2</sup></b>	<b>1500m<sup>2</sup></b>	<b>5200m<sup>2</sup></b>
ATTENUATION CAPACITY	<b>0.0177m<sup>3</sup>/m</b>	<b>0.0398m<sup>3</sup>/m</b>	<b>0.0962m<sup>3</sup>/m</b>
ACCESS/OUTLET/INLET/ SILT CHAMBERS	✓	✓	✓
Q-SLOT ACCESS CHAMBER, COVER AND FRAME	✓	✓	✓

	ACO Qmax® 550	ACO Qmax® 700	ACO Qmax® 900
	Page 47	Page 52	Page 57
			
UNIT	<b>550</b>	<b>700</b>	<b>900</b>
HYDRAULIC CAPACITY			
CATCHMENT AREA*	<b>8400m<sup>2</sup></b>	<b>16600m<sup>2</sup></b>	<b>31700m<sup>2</sup></b>
ATTENUATION CAPACITY	<b>0.1544m<sup>3</sup>/m</b>	<b>0.2501m<sup>3</sup>/m</b>	<b>0.4135m<sup>3</sup>/m</b>
ACCESS/OUTLET/INLET/ SILT CHAMBERS	✓	✓	✓
Q-SLOT ACCESS CHAMBER, COVER AND FRAME	✗	✗	✗

\* Catchment area. Example run based on 100m length laid level at 50mm/hr rainfall.

These products are subject to weight and dimensional tolerances. The dimensions shown on this page are for guidance purposes only.

# ACO Qmax® edge rails

## Composite edge rails

ACO Qmax® edge rails are available in seven different finishes, and are suitable for all channel sizes. To summarise the available options, the product selector

below displays key features for each of the different profiles and finishes available including details of slot width and typical applications.

- Tough and durable thermoset composite construction
- Weight savings for easier installation
- Will not rust / UV stable / flame resistant
- Bolted rail connection for easy on site assembly and accurate alignment

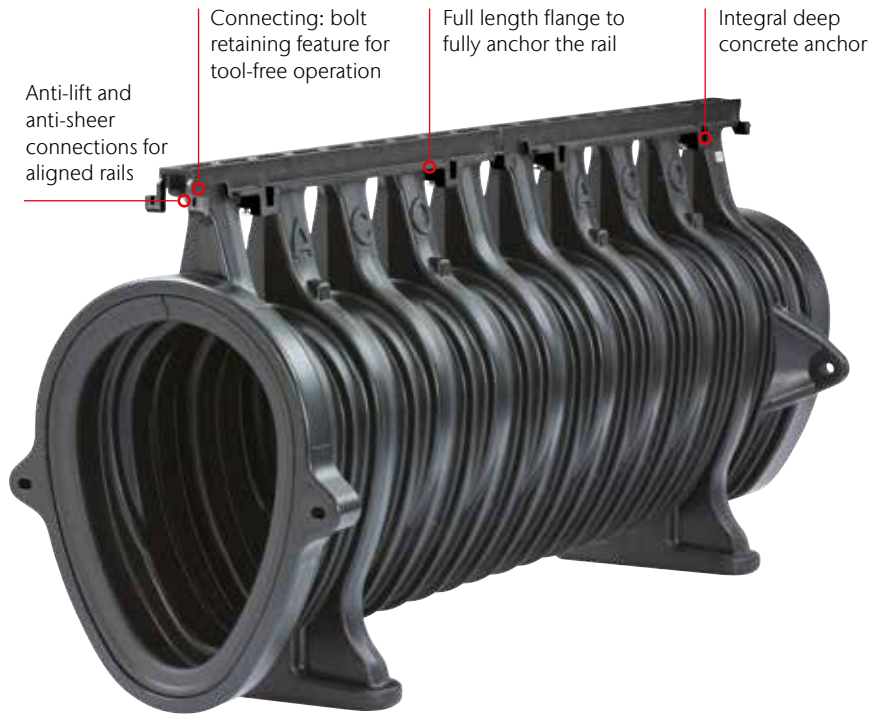

**Q-Flow Ductile Iron**

**Q-Guard Ductile Iron**



<b>Finish</b>	ATec coated ductile iron*	ATec coated ductile iron*
<b>Load Class</b>	A 15 to F 900	A 15 to F 900
<b>Typical Applications</b>	Commercial, industrial, highways, docks and airports	Car parking, petrol forecourts, retail, commercial and airports
<b>Pavement Type</b>	Concrete and asphalt	Concrete and asphalt
<b>Slot Width</b>	26mm	8mm twin slot
<b>Intake Area</b>	18775mm <sup>2</sup> /m	10925mm <sup>2</sup> /m
<b>Chemical Resistant</b>	Effluents, oils, petrol, diesel, road salts and de-icing agents	Effluents, oils, petrol, diesel, road salts and de-icing agents
<b>Rail Protector</b>	Edge protectors available	Edge protectors available

\* Long lasting corrosion protection



**Q-Flow Composite Black****Q-Guard Composite Black**

<b>Finish</b>	Composite plastic	Composite plastic
<b>Load Class</b>	A 15 to F 900	A 15 to F 900
<b>Typical Applications</b>	Commercial, industrial, highways, docks and airports	Car parking, petrol forecourts, retail, commercial and airports
<b>Pavement Type</b>	Concrete and asphalt	Concrete
<b>Slot Width</b>	25mm	9mm
<b>Intake Area</b>	18400mm <sup>2</sup> /m	10700mm <sup>2</sup> /m
<b>Chemical Resistant</b>	Effluent, oils, petrol, diesel, road salts and de-icing agents	Effluent, oils, petrol, diesel, road salts and de-icing agents
<b>Rail Protector</b>	Supplied with channel	Supplied with channel

**Q-Flow Steel****Q-Guard Steel****Q-Slot Steel**

<b>Finish</b>	Hot dipped galvanised steel	Hot dipped galvanised steel	Hot dipped galvanised steel
<b>Load Class</b>	A 15 to F 900	A 15 to F 900	A 15 to D 400
<b>Typical Applications</b>	Commercial, industrial, highways, docks and airports	Car parking, petrol forecourts, retail, commercial and airports	Landscaping, town centres, car parking, retail and commercial applications
<b>Pavement Type</b>	Concrete	Concrete and asphalt	Block, slab and natural stone (designed for paving material up to 100mm thick)
<b>Slot Width</b>	26mm	10mm	10mm discreet slot
<b>Intake Area</b>	18106mm <sup>2</sup> /m	8356mm <sup>2</sup> /m	10000mm <sup>2</sup> /m
<b>Chemical Resistant</b>	Effluents, oils, petrol, diesel and road salts	Effluents, oils, petrol, diesel and road salts	Effluents, oils, petrol, diesel, road salts and de-icing agents
<b>Rail Protector</b>	Supplied with channel	Supplied with channel	N/A

# ACO Qmax® accessories

## End caps\*

### Three types of end caps are available:

1. A multifunctional (closing/outlet/inlet) end cap for ACO Qmax® 150, 225 and 350 systems
2. A closing end cap for ACO Qmax® 550, 700 and 900 systems
3. A blanking end cap to suit cut channel for ACO Qmax® 550, 700 and 900 systems



Multifunctional end cap for 150, 225 and 350 systems



Closing end cap for 550, 700 and 900 systems

## Step connectors\*

### Four step connectors are available to provide connection between:

1. ACO Qmax® 150 to 225 systems
2. ACO Qmax® 225 to 350 systems
3. ACO Qmax® 550 to 700 systems
4. ACO Qmax® 700 to 900 systems



Step connector for 150 to 225 & 225 to 350 systems



Step connector for 550 to 700 & 700 to 900 systems

## Chamber connectors\*

### Three chamber connectors are available for:

1. ACO Qmax® 550 system
2. ACO Qmax® 700 system
3. ACO Qmax® 900 system



Chamber connector for 550, 700 & 900 systems

## Downpipe connectors\*

### Engineered solution to connect building curtilage downpipe connections with the Qmax® system

- Comes in two different sizes: Ø110 Downpipe connector for the Qmax® 225 & 350 and the Ø160 Downpipe connector for Qmax® 550, 700 & 900
- Polyethylene construction is the same material as the Qmax® channels
- Both pipe connectors can be installed at 200mm increments down the length of the channels
- Parts come packaged with all fixings and assembly instructions



Ø110 Downpipe connector for 225 & 350



Ø160 Downpipe connector for 550, 700 & 900

\* Functions and features are included in the relevant product chapters.

Access chambers providing outlet/inlet connections and silt management are available for each size in the ACO Qmax® system. For more information see: ACO Qmax® 150, 225 & 350 chambers – page 44 and ACO Qmax® 550, 700 & 900 chambers – page 63.

# ACO Qmax® 150





The ACO Qmax® 150 channel is manufactured from Polyethylene (PE), with recycled material which is lightweight, chemically resistant and extremely robust. Its circular bore, sealed push fit channel connections and unique patented inlet design ensure drainage inverts are kept to a minimum, installation rates are maximised and the product is fully integrated within the pavement detail providing long term dependable performance.

ACO Qmax® 150 channels are available with the following components:

- Outlet and closing end cap
- Qmax 150-225 step connector
- Access, outlet / inlet and silt chambers
- Installation edge rail protectors
- Q-Brake Vortex flow controls



150	Unit
	Hydraulic capacity
390m <sup>2</sup>	Catchment area*
0.0177m <sup>3</sup> /m	Attenuation capacity
	Access/outlet/inlet/silt chambers
	Q-slot access chamber, cover and frame

\* Catchment area. Example run based on 100m length laid level at 50mm/hr rainfall.

# ACO Qmax® 150

Product Code	Description	Length [mm]	Width overall [mm]	Depth overall [mm]	Slot width [mm]	Weight [kg]
--------------	-------------	-------------	--------------------	--------------------	-----------------	-------------

**ACO Qmax® 150 with ACO Q-Flow ductile iron edge rail**

32990	ACO Qmax® 150 channel assembly complete with ACO Q-Flow ductile iron edge rail	2010	Ø210	405	26	22
-------	--	------	------	-----	----	----

ACO Qmax® 150 with ACO Q-Flow ductile iron edge rail

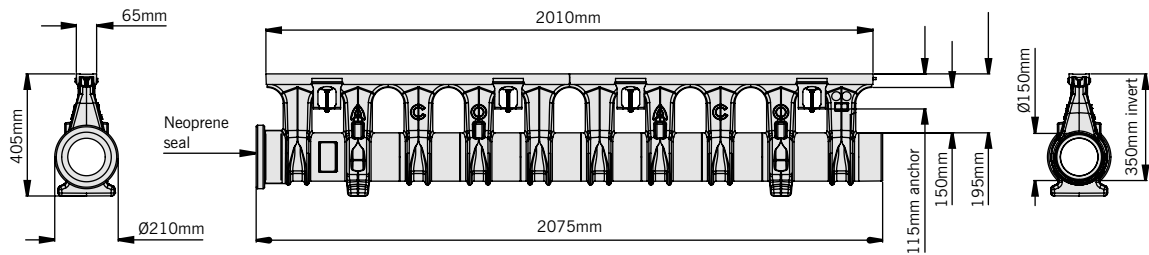

**ACO Qmax® 150 with ACO Q-Guard ductile iron edge rail**

32991	ACO Qmax® 150 channel assembly complete with ACO Q-Guard ductile iron edge rail	2010	Ø210	405	2 x 8	23
-------	---	------	------	-----	-------	----

ACO Qmax® 150 with ACO Q-Flow ductile iron edge rail

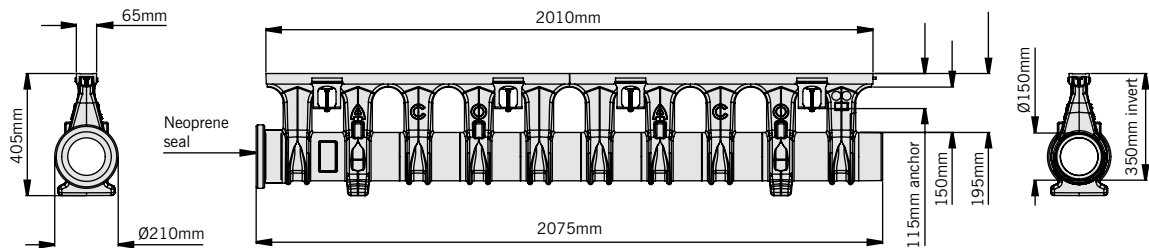

**ACO Qmax® 150 with ACO Q-Flow composite edge rail**

32893	ACO Qmax® 150 channel assembly complete with ACO Q-Flow composite edge rail - Black	2010	Ø210	405	25	13.3
-------	---	------	------	-----	----	------

ACO Qmax® 150 with ACO Q-Flow composite edge rail

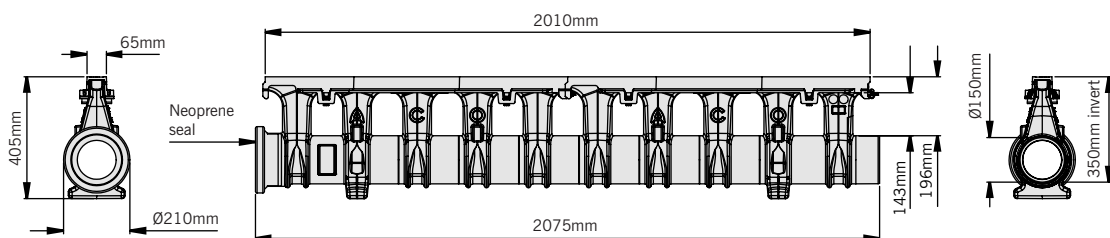



# ACO Qmax® 150

Product Code	Description	Length [mm]	Width overall [mm]	Depth overall [mm]	Slot width [mm]	Weight [kg]
--------------	-------------	-------------	--------------------	--------------------	-----------------	-------------

### ACO Qmax® 150 with ACO Q-Guard composite edge rail

32894	ACO Qmax® 150 channel assembly complete with ACO Q-Guard composite edge rail - Black	2010	Ø210	405	9	13.6
-------	--	------	------	-----	---	------

ACO Qmax® 150 with ACO Q-Guard composite edge rail

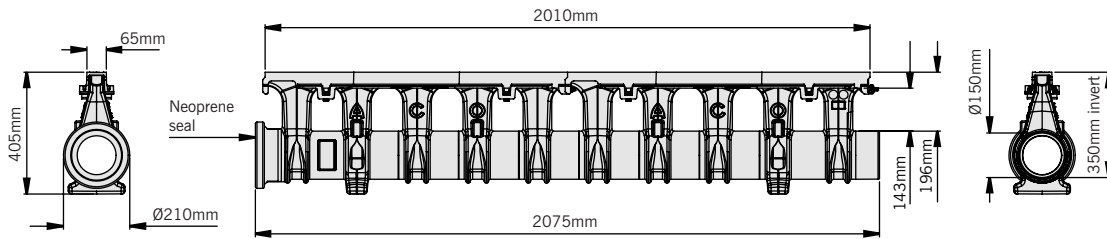

### ACO Qmax® 150 with ACO Q-Flow galvanised steel edge rail

32992	ACO Qmax® 150 channel assembly complete with ACO Q-Flow galvanised steel edge rail	2010	Ø210	405	26	12
-------	--	------	------	-----	----	----

ACO Qmax® 150 with ACO Q-Flow galvanised steel edge rail

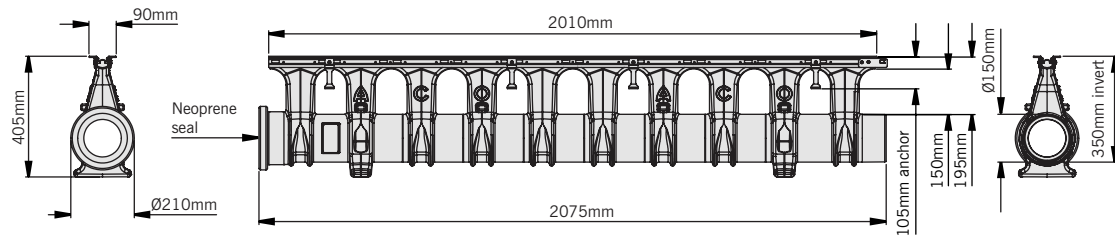

### ACO Qmax® 150 with ACO Q-Guard galvanised steel edge rail

32993	ACO Qmax® 150 channel assembly complete with ACO Q-Guard galvanised steel edge rail	2010	Ø210	405	10	12
-------	---	------	------	-----	----	----

ACO Qmax® 150 with ACO Q-Guard galvanised steel edge rail

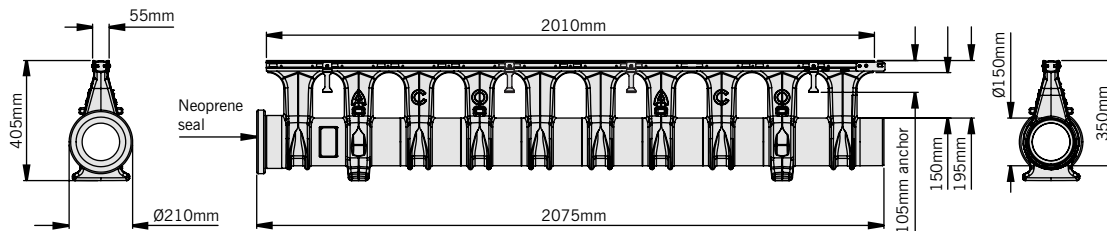

Note: For details regarding the access/outlet/inlet/silt chambers for use with this system please refer to page 32. These products are subject to weight and dimensional tolerances. The dimensions shown on this page are for guidance purposes only.

## ACO Qmax® 150

Product Code	Description	Length [mm]	Width overall [mm]	Depth overall [mm]	Slot width [mm]	Weight [kg]
--------------	-------------	-------------	--------------------	--------------------	-----------------	-------------

### ACO Qmax® 150 with ACO Q-Slot galvanised steel edge rail

32994	ACO Qmax® 150 channel assembly complete with ACO Q-Slot galvanised steel edge rail	2010	Ø210	500	10	20.5
-------	--	------	------	-----	----	------

ACO Qmax® 150 with ACO Q-Slot galvanised steel edge rail

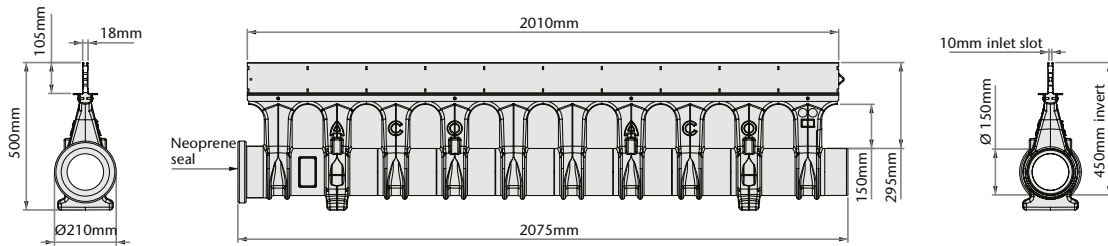

Product Code	Description	Length [mm]	Width overall [mm]	Depth overall [mm]	Weight [kg]
--------------	-------------	-------------	--------------------	--------------------	-------------

### ACO Qmax® 150 multifunctional end cap (closing/outlet/inlet)

32997	ACO Qmax® 150 universal endcap assembly	240	Ø210	-	1
-------	---	-----	------	---	---

ACO Qmax® 150 with ACO Q-Slot galvanised steel edge rail

ACO Qmax® 150 multifunctional end cap has the following functions:

- Male and female closing end cap
- Male and female inlet/outlet end cap for connection to Ø150mm twinwall pipe
- Simple fitting

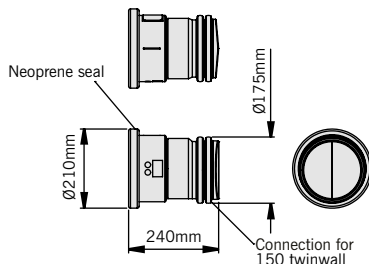

### ACO Qmax® 150 to 225 step connector

32995	ACO Qmax® 150 to 225 step connector (M to F)	-	Ø310	25	0.4
-------	--	---	------	----	-----

ACO Qmax® 150 to 225 step connector

ACO Qmax® 150 to 225 step connector has the following functions:

- Enables step fall installations of ACO Qmax® 150 and ACO Qmax® 225 channels
- For use between ACO Qmax® 150 male and ACO Qmax® 225 female channel connections
- Simple fitting

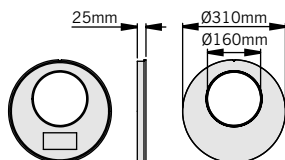

### ACO Qmax® ductile iron edge rail protector

32854	ACO Qmax® ductile iron edge rail protector 15.25m roll	15.25	65	1.5	5.0
-------	--	-------	----	-----	-----

ACO Qmax® ductile iron edge rail protector has the following functions:

- Used to cover and protect rails from debris during installation
- Simple fitting
- Can be reused

# ACO Qmax® 225





The ACO Qmax® 225 channel is manufactured from Polyethylene (PE), with recycled material which is lightweight, chemically resistant and extremely robust. Its circular bore, sealed push fit channel connections and unique patented inlet design ensure drainage inverts are kept to a minimum, installation rates are maximised and the product is fully integrated within the pavement detail providing long term dependable performance.

ACO Qmax® 225 channels are available with the following components:

- Outlet and closing end cap
- Qmax 225-350 step connector
- Access, outlet / inlet and silt chambers
- Installation edge rail protectors
- Q-Brake Vortex flow controls



225	Unit
	Hydraulic capacity
1500m <sup>2</sup>	Catchment area*
0.0398m <sup>3</sup> /m	Attenuation capacity
	Access/outlet/inlet/silt chambers
	Q-slot access chamber, cover and frame

\* Catchment area. Example run based on 100m length laid level at 50mm/hr rainfall.

## ACO Qmax® 225

Product Code	Description	Length [mm]	Width overall [mm]	Depth overall [mm]	Slot width [mm]	Weight [kg]
--------------	-------------	-------------	--------------------	--------------------	-----------------	-------------

### ACO Qmax® 225 with ACO Q-Flow ductile iron edge rail

32800	ACO Qmax® 225 channel assembly complete with ACO Q-Flow ductile iron edge rail	2010	Ø290	480	26	24
-------	--	------	------	-----	----	----

ACO Qmax® 225 with ACO Q-Flow ductile iron edge rail

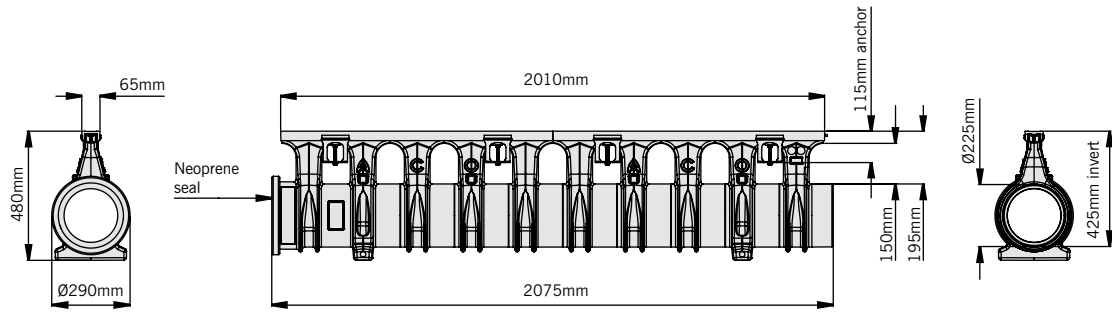

### ACO Qmax® 225 with ACO Q-Guard ductile iron edge rail

32801	ACO Qmax® 225 channel assembly complete with ACO Q-Guard ductile iron edge rail	2010	Ø290	480	2 x 8	25
-------	---	------	------	-----	-------	----

ACO Qmax® 225 with ACO Q-Guard ductile iron edge rail

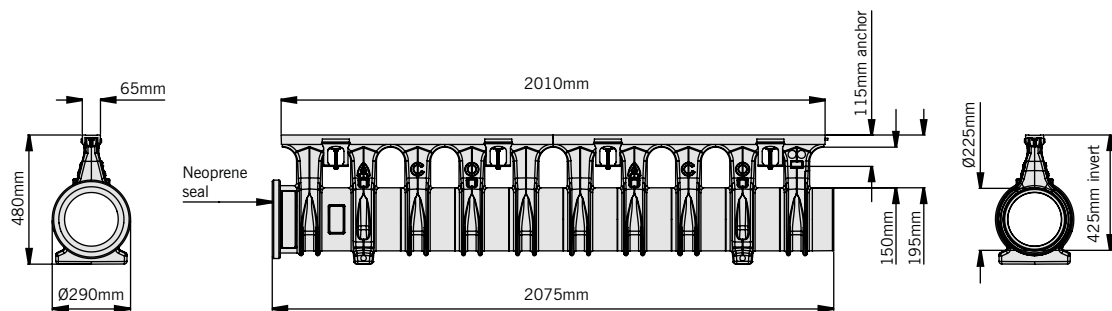

### ACO Qmax® 225 with ACO Q-Flow composite edge rail

32905	ACO Qmax® 225 channel assembly complete with ACO Q-Flow composite edge rail - Black	2010	Ø290	480	25	15.8
-------	---	------	------	-----	----	------

ACO Qmax® 225 with ACO Q-Flow composite edge rail

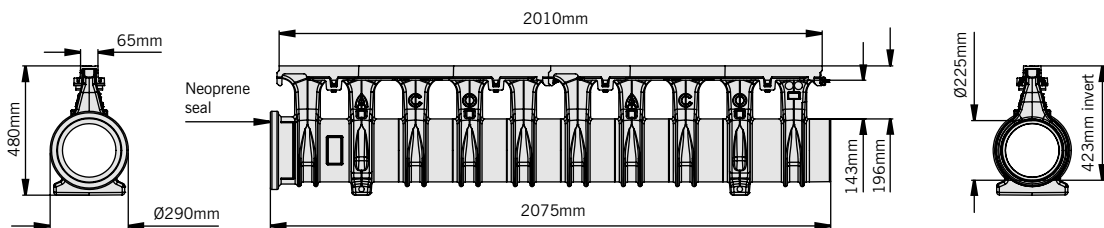



# ACO Qmax® 225

Product Code	Description	Length [mm]	Width overall [mm]	Depth overall [mm]	Slot width [mm]	Weight [kg]
--------------	-------------	-------------	--------------------	--------------------	-----------------	-------------

**ACO Qmax® 225 with ACO Q-Guard composite edge rail**

32906	ACO Qmax® 225 channel assembly complete with ACO Q-Guard composite edge rail - Black	2010	Ø290	480	9	16.1
-------	--	------	------	-----	---	------

ACO Qmax® 225 with ACO Q-Guard composite edge rail

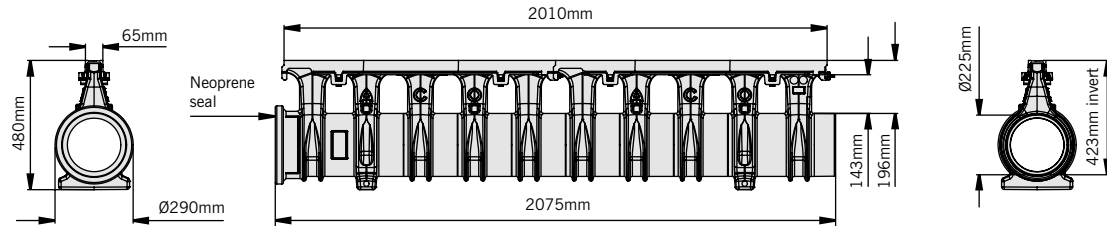

**ACO Qmax® 225 with ACO Q-Flow galvanised steel edge rail**

32802	ACO Qmax® 225 channel assembly complete with ACO Q-Flow galvanised steel edge rail	2010	Ø290	480	26	17.8
-------	--	------	------	-----	----	------

ACO Qmax® 225 with ACO Q-Flow galvanised steel edge rail

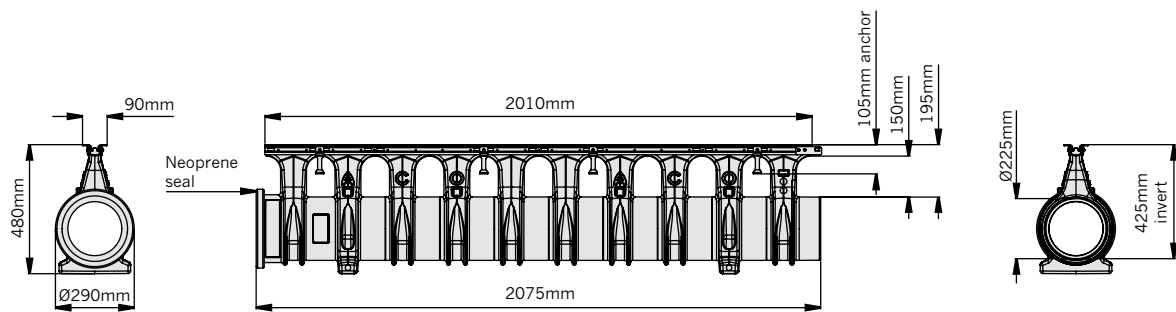

Note: For details regarding the access/outlet/inlet/silt chambers for use with this system please refer to page 32. These products are subject to weight and dimensional tolerances. The dimensions shown on this page are for guidance purposes only.

## ACO Qmax® 225

Product Code	Description	Length [mm]	Width overall [mm]	Depth overall [mm]	Slot width [mm]	Weight [kg]
--------------	-------------	-------------	--------------------	--------------------	-----------------	-------------

### ACO Qmax® 225 with ACO Q-Guard galvanised steel edge rail

32803	ACO Qmax® 225 channel assembly complete with ACO Q-Guard galvanised steel edge rail	2010	Ø290	480	10	15.3
-------	---	------	------	-----	----	------

ACO Qmax® 225 with ACO Q-Guard galvanised steel edge rail

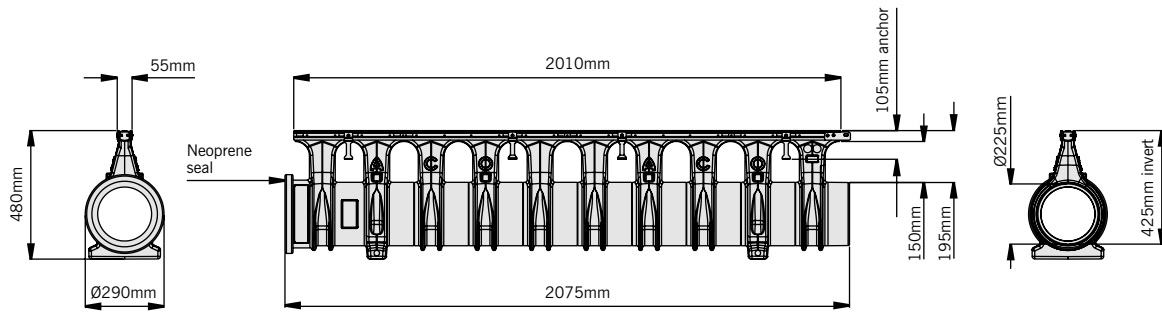

### ACO Qmax® 225 with ACO Q-Slot galvanised steel edge rail

32804	ACO Qmax® 225 channel assembly complete with ACO Q-Slot galvanised steel edge rail	2010	Ø290	580	10	22.9
-------	--	------	------	-----	----	------

ACO Qmax® 225 with ACO Q-Slot galvanised steel edge rail

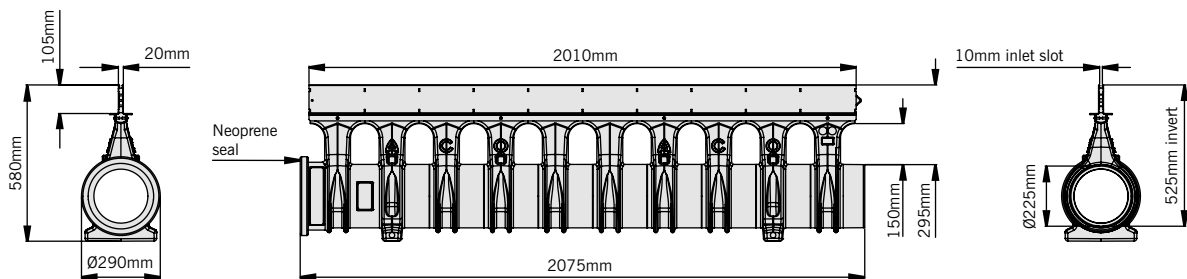

## ACO Qmax® 225

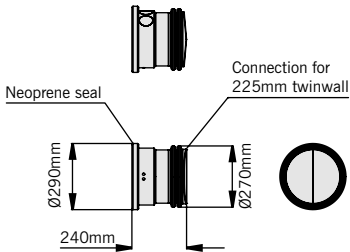
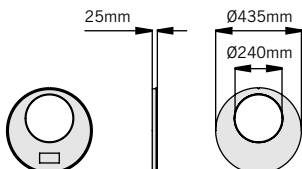
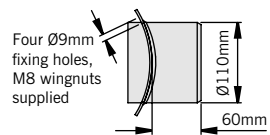
Product Code	Description	Length [mm]	Width overall [mm]	Depth overall [mm]	Weight [kg]
<b>ACO Qmax® 225 multifunctional end cap (closing/outlet/inlet)</b>					
42221	ACO Qmax® 225 multifunctional end cap	240	Ø290	Ø290	1.4
	ACO Qmax® 225 multifunctional end cap				
					
	ACO Qmax® 225 multifunctional end cap has the following functions:				
	<ul style="list-style-type: none"> <li>■ Male and female closing end cap</li> <li>■ Male and female inlet/outlet end cap for connection to Ø225mm twinwall pipe</li> <li>■ Simple fitting</li> </ul>				
<b>ACO Qmax® 225 to 350 step connector</b>					
32880	ACO Qmax® 225 to 350 step connector (M to F)	25	Ø435	-	0.8
	ACO Qmax® 150 to 225 step connector				
					
	ACO Qmax® 225 to 350 step connector has the following functions:				
	<ul style="list-style-type: none"> <li>■ Enables step fall installations of ACO Qmax® 225 and ACO Qmax® 350 channels</li> <li>■ For use between ACO Qmax® 225 male and ACO Qmax® 350 female channel connections</li> <li>■ Simple fitting</li> </ul>				
<b>ACO Qmax® 225 downpipe connector</b>					
44344	ACO Qmax® 225 downpipe connector Ø110mm outlet	100	120	146	0.16
	ACO Qmax® 150 to 225 step connector				
					
	ACO Qmax® 225 downpipe connector has the following functions:				
	<ul style="list-style-type: none"> <li>■ Allows the connection of rain water pipes into the body of Qmax channels</li> <li>■ Simple fitting</li> </ul>				
<b>ACO Qmax® ductile iron edge rail protector</b>					
32854	ACO Qmax® ductile iron edge rail protector 15.25m roll	15.25	65	1.5	5.0
	ACO Qmax® ductile iron edge rail protector has the following functions:				
	<ul style="list-style-type: none"> <li>■ Used to cover and protect rails from debris during installation</li> <li>■ Simple fitting</li> <li>■ Can be reused</li> </ul>				

Note: For details regarding the access/outlet/inlet/silt chambers for use with this system please refer to page 32. These products are subject to weight and dimensional tolerances. The dimensions shown on this page are for guidance purposes only.

# ACO Qmax® 350



The ACO Qmax® 350 channel is manufactured from Polyethylene (PE), with recycled material which is lightweight, chemically resistant and extremely robust.



Its circular bore, sealed push fit channel connections and unique patented inlet design ensure drainage inverts are kept to a minimum, installation rates are maximised and the product is fully integrated within the pavement detail providing long term dependable performance.

ACO Qmax® 350 channels are available with the following components:

- Outlet/inlet and closing end cap
- Access, outlet / inlet and silt chambers
- Installation edge rail protectors
- Q-Brake Vortex flow controls



40

350	Unit
	Hydraulic capacity
5200m <sup>2</sup>	Catchment area*
0.0962m <sup>3</sup> /m	Attenuation capacity
	Access/outlet/inlet/silt chambers
	Q-slot access chamber, cover and frame

\* Catchment area. Example run based on 100m length laid level at 50mm/hr rainfall.



# ACO Qmax® 350

Product Code	Description	Length [mm]	Width overall [mm]	Depth overall [mm]	Slot width [mm]	Weight [kg]
--------------	-------------	-------------	--------------------	--------------------	-----------------	-------------

### ACO Qmax® 350 with ACO Q-Flow ductile iron edge rail

32810	ACO Qmax® 350 channel assembly complete with ACO Q-Flow ductile iron edge rail	2010	Ø415	600	26	28.3
-------	--	------	------	-----	----	------

ACO Qmax® 350 with ACO Q-Flow ductile iron edge rail

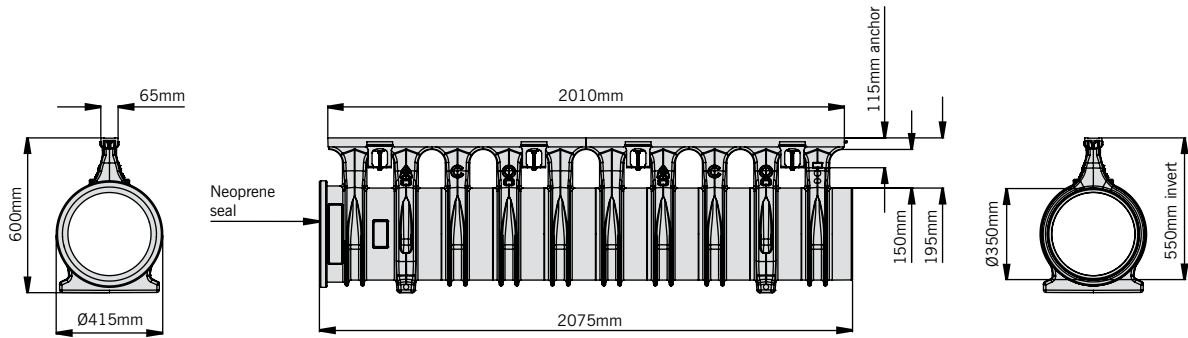

### ACO Qmax® 350 with ACO Q-Guard ductile iron edge rail

32811	ACO Qmax® 350 channel assembly complete with ACO Q-Guard ductile iron edge rail	2010	Ø415	600	2 x 8	29.3
-------	---	------	------	-----	-------	------

ACO Qmax® 350 with ACO Q-Guard ductile iron edge rail

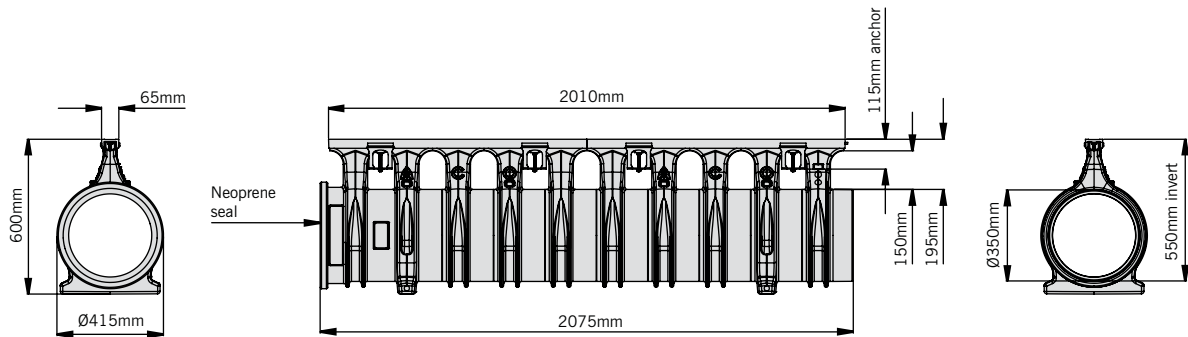

### ACO Qmax® 350 with ACO Q-Flow composite edge rail

32915	ACO Qmax® 350 channel assembly complete with ACO Q-Flow composite edge rail - Black	2010	Ø415	600	25	21.5
-------	---	------	------	-----	----	------

ACO Qmax® 350 with ACO Q-Flow composite edge rail

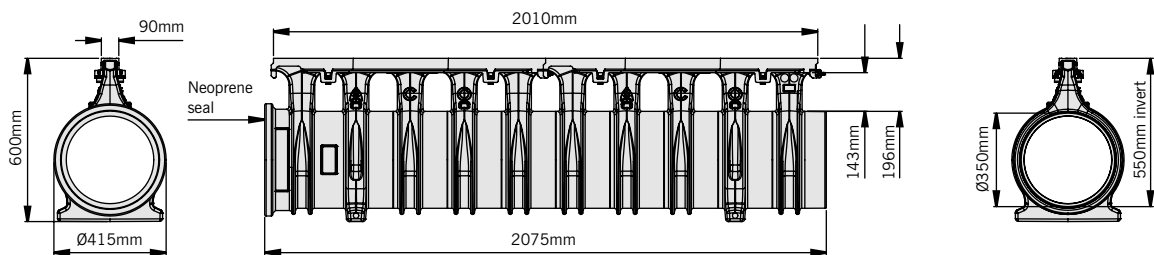

Note: For details regarding the access/outlet/inlet/silt chambers for use with this system please refer to page 32.

# ACO Qmax® 350

Product Code	Description	Length [mm]	Width overall [mm]	Depth overall [mm]	Slot width [mm]	Weight [kg]
--------------	-------------	-------------	--------------------	--------------------	-----------------	-------------

**ACO Qmax® 350 with ACO Q-Guard composite edge rail**

32916	ACO Qmax® 350 channel assembly complete with ACO Q-Guard composite edge rail -Black	2010	Ø415	600	9	21.8
-------	---	------	------	-----	---	------

ACO Qmax® 350 with ACO Q-Guard composite edge rail

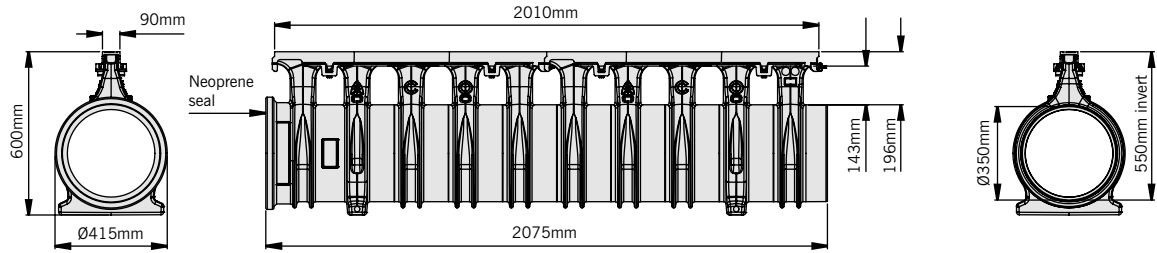

**ACO Qmax® 350 with ACO Q-Flow galvanised steel edge rail**

32812	ACO Qmax® 350 channel assembly complete with ACO Q-Flow galvanised steel edge rail	2010	Ø415	600	26	24.0
-------	--	------	------	-----	----	------

ACO Qmax® 350 with ACO Q-Flow galvanised steel edge rail

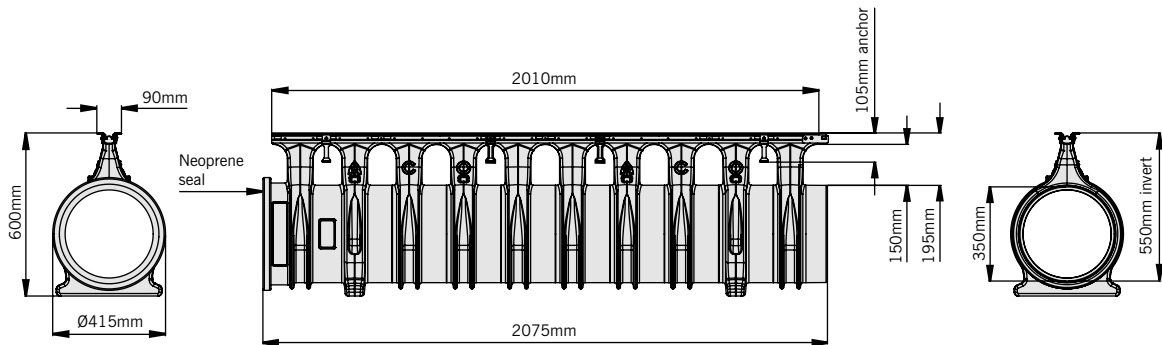

**ACO Qmax® 350 with ACO Q-Guard galvanised steel edge rail**

32813	ACO Qmax® 350 channel assembly complete with ACO Q-Guard galvanised steel edge rail	2010	Ø415	600	10	21.5
-------	---	------	------	-----	----	------

ACO Qmax® 350 with ACO Q-Guard galvanised steel edge rail

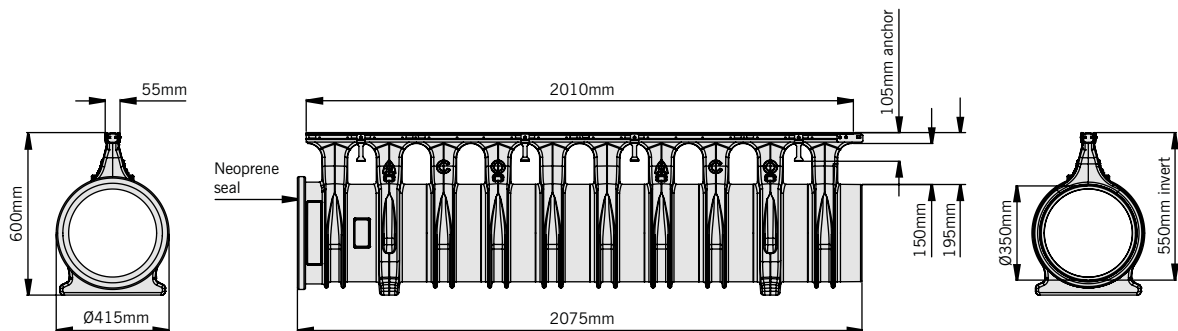

## ACO Qmax® 350

Product Code	Description	Length [mm]	Width overall [mm]	Depth overall [mm]	Slot width [mm]	Weight [kg]
32814	ACO Qmax® 350 channel assembly complete with ACO Q-Slot galvanised steel edge rail	2010	Ø415	700	10	29.1

ACO Qmax® 350 with ACO Q-Slot galvanised steel edge rail

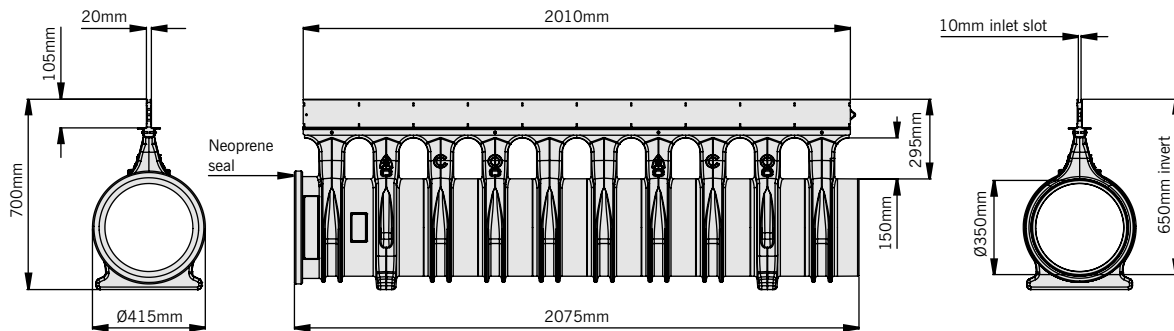

Product Code	Description	Length [mm]	Width overall [mm]	Depth overall [mm]	Weight [kg]
--------------	-------------	-------------	--------------------	--------------------	-------------

## ACO Qmax® 350 multifunctional end cap (closing/outlet/inlet)

42351	ACO Qmax® 350 multifunctional end cap	260	Ø415	Ø415	2.6
-------	---------------------------------------	-----	------	------	-----

ACO Qmax® 350 multifunctional end cap

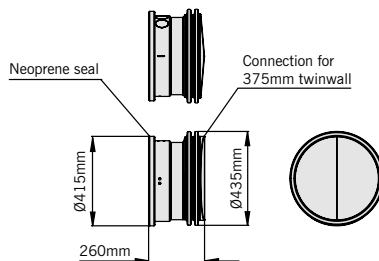

ACO Qmax® 350 multifunctional end cap has the following functions:

- Male and female closing end cap
- Male and female inlet/outlet end cap for connection to 375mm twinwall pipe
- Simple fitting

## ACO Qmax® 350 downpipe connector

44344	ACO Qmax® 350 downpipe connector Ø110mm outlet	100	120	146	0.16
-------	--	-----	-----	-----	------

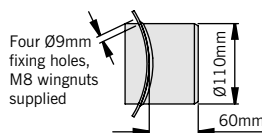

ACO Qmax® 350 downpipe connector has the following functions:

- Allows the connection of rain water pipes into the body of Qmax channels
- Simple fitting

## ACO Qmax® ductile iron edge rail protector

32854	ACO Qmax® ductile iron edge rail protector 15.25m roll	15.25	65	1.5	5.0
-------	--	-------	----	-----	-----

ACO Qmax® ductile iron edge rail protector has the following functions:

- Used to cover and protect rails from debris during installation
- Simple fitting
- Can be reused

Note: For details regarding the access/outlet/inlet/silt chambers for use with this system please refer to page 32. These products are subject to weight and dimensional tolerances. The dimensions shown on this page are for guidance purposes only.

## ACO Qmax® 150, 225 and 350 access, outlet/inlet and silt chambers

ACO Qmax® 150, 225 & 350 access, outlet/inlet and silt chambers provide a compact and economical method of gaining access to the channel system for maintenance and cleaning, connections to traditional underground drainage networks, or silt management.

These chambers are specifically designed for use with ACO Qmax® 150, 225 and 350 channels and allow 4-way channel connections to be made for simple directional changes and optimised scheme designs.

The three arrangements allow flexibility to Qmax installations, and depending on pipe connections can be used purely as an access point or an access unit incorporating a silt chamber.

ACO Qmax® outlet/inlet and silt chambers provide outlet pipe connection to 160mm PVC-U, 200mm, 225mm and 300mm twinwall or clay pipe work. They also allow 110mm PVC-U inlet connections to be made, reducing the need for additional underground pipe work.



ACO Qmax® access, outlet/inlet and silt chambers are manufactured from PE which is lightweight, tough and chemically resistant.

### Cover and frame options

The chambers come complete with a ductile iron slotted cover and frame available in either a lockable D 400 or hinged F 900 versions. An ACO Q-Slot D 400 galvanised steel recessed cover and frame for use with up to 100mm block paving, slab and natural stone is also available.

Materials used in the construction of ACO Qmax® chambers contain high levels of recycled materials and are themselves recyclable at the end of their life.



D 400 / F 900 ductile iron slotted cover and frame



ACO Q-Slot D 400 galvanised steel recessed cover and frame

## ACO Qmax® 150, 225 and 350 shallow access chamber with silt collection

ACO Qmax® 150, 225 & 350 shallow access chambers provide a compact method of local silt management whilst also providing access to the channel system for maintenance and cleaning.

These chambers are specifically designed for use with ACO Qmax® 150, 225 and 350 channels and allow 4-way channel connections combined with a silt collection within shallow installations.

### Cover and frame options

The chambers are supplied with a ductile iron slotted cover and frame available in either a lockable D 400 or F 900 versions.

Materials used in the construction of ACO Qmax® chambers contain high levels of recycled materials and are themselves recyclable at the end of their life.





# ACO Qmax® 150, 225 and 350 access, outlet/inlet and silt chambers

Product Code	Description	Length [mm]	Width overall [mm]	Depth overall [mm]	Slot width [mm]	Weight [kg]
<b>ACO Qmax® 150, 225 and 350 channel access, outlet/inlet and silt chambers with slotted cover and frame</b>						
32970	Access chamber with D 400 slotted cover and frame	565	565	640	10	48
32971	Access chamber with F 900 slotted cover and frame	660	660	640	19	77.5
32972	Outlet/inlet chamber with D 400 slotted cover and frame	565	565	1095	52	
32973	Outlet/inlet chamber with F 900 slotted cover and frame	660	660	1095	19	81.5
32974	Outlet/inlet/Silt chamber with D 400 slotted cover and frame	565	565	1600	10	60
32975	Outlet/inlet/Silt chamber with F 900 slotted cover and frame	660	660	1600	19	89.5

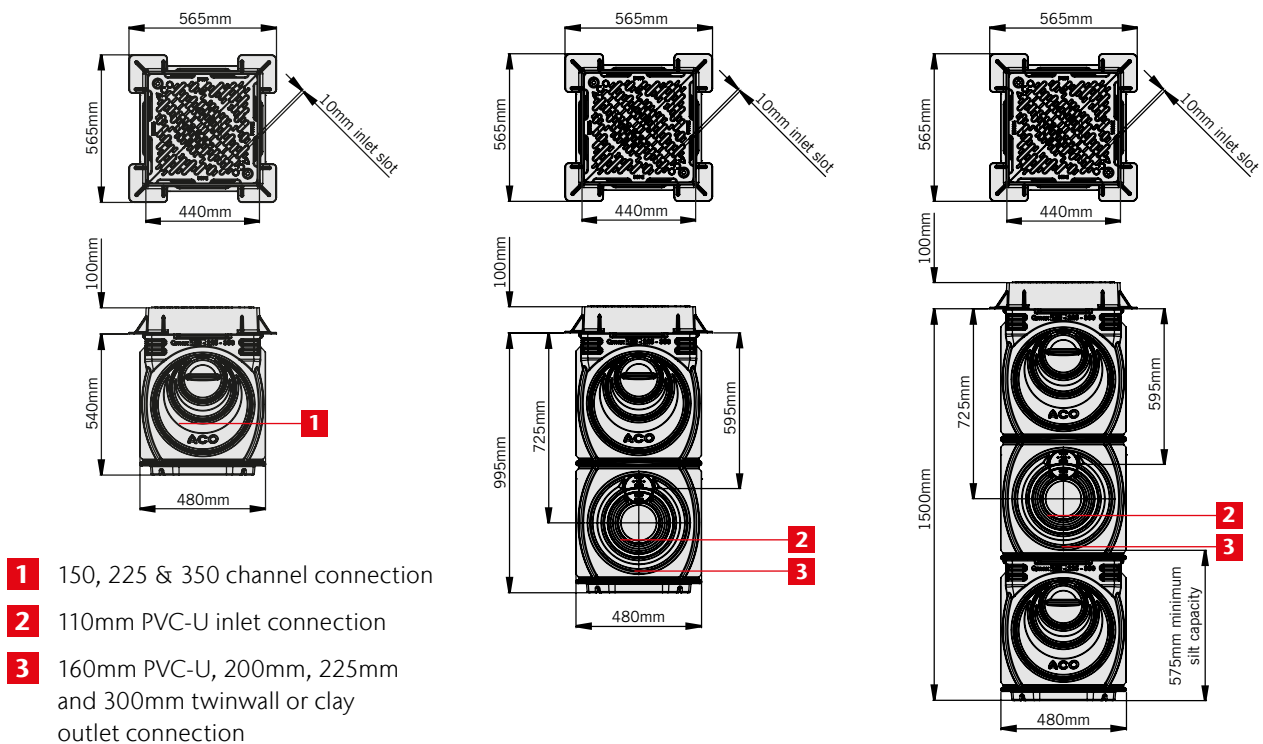

Image shows ACO Qmax® 150, 225 and 350 access chamber with D 400 slotted cover and frame. Also available in Load Class F 900.

Image shows ACO Qmax® 150, 225 and 350 access/outlet/inlet chamber with D 400 slotted cover and frame. Also available in Load Class F 900.

Image shows ACO Qmax® 150, 225 and 350 access/outlet/inlet/silt chamber with D 400 slotted cover and frame. Also available in Load Class F 900.

## ACO Qmax® 150, 225 and 350 shallow channel access, outlet/inlet and silt chamber with slotted cover and frame

46110	Shallow access chamber and silt collection with D 400 slotted cover and frame	760	760	885	21	97.5
46111	Shallow access chamber and silt collection with D 400 solid cover and frame	760	760	885	-	92
46112	Shallow access chamber and silt collection with F 900 slotted cover and frame	760	760	885	21	122
46113	Shallow access chamber and silt collection with F 900 solid cover and frame	760	760	885	-	110

These products are subject to weight and dimensional tolerances. The dimensions shown on this page are for guidance purposes only.

# ACO Qmax® 150, 225 and 350 access, outlet/inlet and silt chambers

Product Code	Description	Length [mm]	Width overall [mm]	Depth overall [mm]	Slot width [mm]	Weight [kg]
32976	Access chamber with D 400 ACO Q-Slot recessed cover and frame	520	520	740	10	55.5
32977	Outlet/inlet chamber with D 400 ACO Q-Slot recessed cover and frame	520	520	1195	59.5	
32978	Outlet/inlet/silt chamber with D 400 ACO Q-Slot recessed cover and frame	520	520	1700	10	67.5

ACO Qmax® 150, 225 and 350 access chamber with D 400 ACO Q-Slot recessed cover and frame.

ACO Qmax® 150, 225 and 350 outlet/inlet chamber with D 400 ACO Q-Slot recessed cover and frame.

ACO Qmax® 150, 225 and 350 outlet/inlet/silt chamber with D 400 ACO Q-Slot recessed cover and frame.

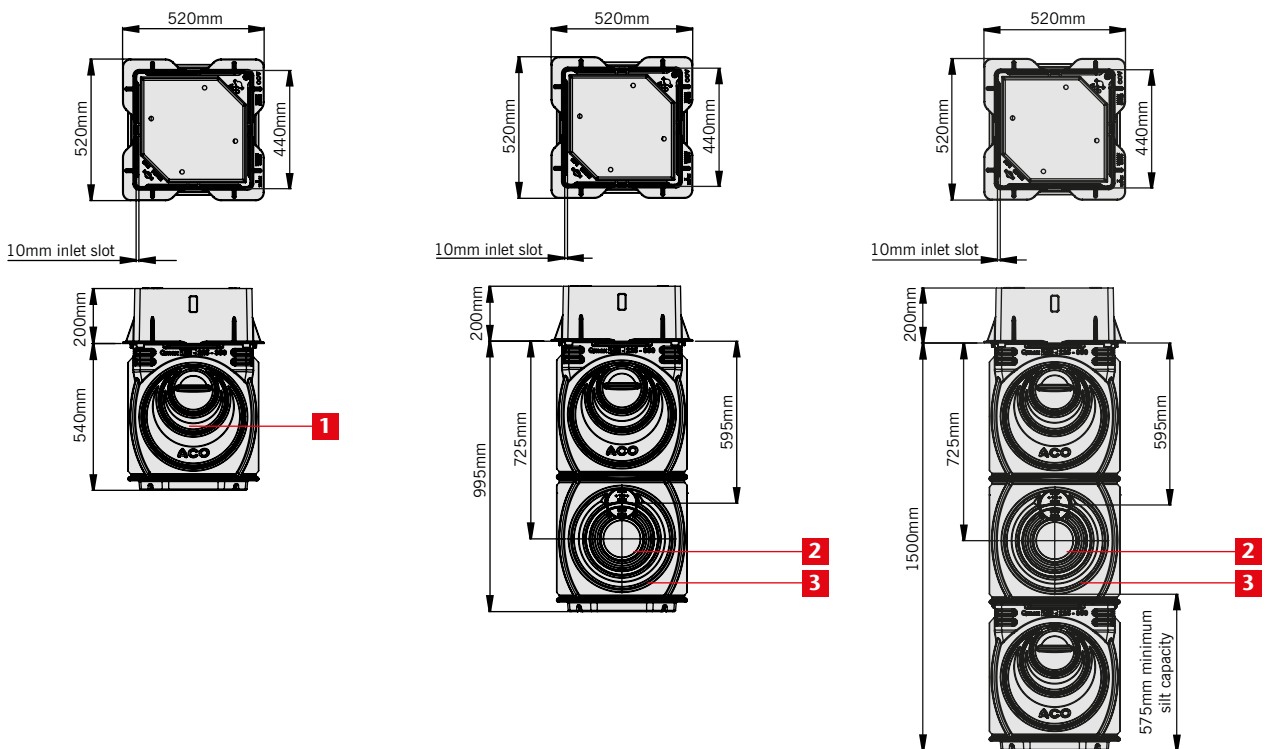

- 1** 150, 225 & 350 channel connection
- 2** 110mm PVC-U inlet connection
- 3** 160mm PVC-U, 200mm, 225mm and 300mm twinwall or clay outlet connection

### Maximum outlet capacity

(assuming water level to the crown of the channel bore)

160mm	200mm	225mm	300mm
45 l/s	71 l/s	90 l/s	159 l/s

Table and values apply to 32970 to 32975 also

# ACO Qmax® 550





The ACO Qmax® 550 channel is manufactured from Polyethylene (PE), with recycled material which is lightweight, chemically resistant and extremely robust. Its ovoid High-Flow bore, sealed push fit channel connections and unique patented inlet design ensure efficient drainage even at low hydraulic flows and promote self cleansing. Installation rates are maximised and the product is fully integrated within the pavement detail providing long term dependable performance. The increased hydraulic capacity of the ACO Qmax® 550 channel makes it ideal for larger catchments and can eliminate the need for additional carrier drains and pipework.

ACO Qmax® 550 channels are available with the following components:

- Outlet, closing and blanking end caps
- Qmax 550-700 step connector
- Access and silt chambers
- Installation edge rail protectors
- Q-Brake Vortex flow controls



550	Unit
	Hydraulic capacity
8400m <sup>2</sup>	Catchment area*
0.1544m <sup>3</sup> /m	Attenuation capacity
	Access/outlet/inlet/silt chambers
	Q-slot access chamber, cover and frame

\* Catchment area. Example run based on 100m length laid level at 50mm/hr rainfall.

## ACO Qmax® 550

Product Code	Description	Length [mm]	Width overall [mm]	Depth overall [mm]	Slot width [mm]	Weight [kg]
--------------	-------------	-------------	--------------------	--------------------	-----------------	-------------

### ACO Qmax® 550 with ACO Q-Flow ductile iron edge rail

32820	ACO Qmax® 550 channel assembly complete with ACO Q-Flow ductile iron edge rail	2010	635	920	26	44
-------	--	------	-----	-----	----	----

ACO Qmax® 550 with ACO Q-Flow ductile iron edge rail

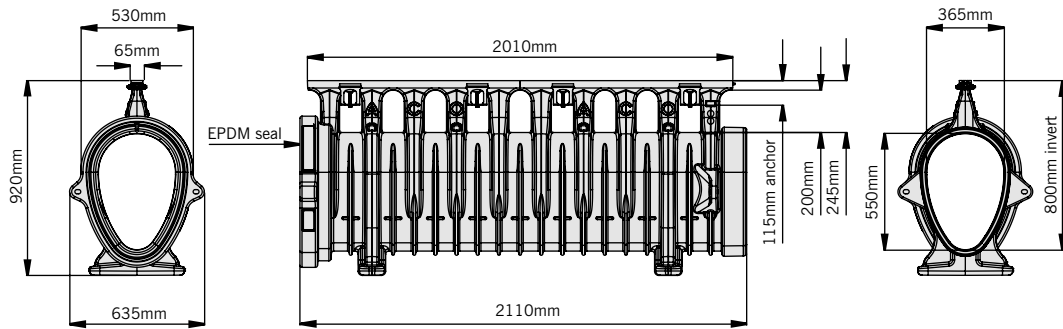

### ACO Qmax® 550 with ACO Q-Guard ductile iron edge rail

32821	ACO Qmax® 550 channel assembly complete with ACO Q-Guard ductile iron edge rail	2010	635	920	2 x 8	45
-------	---	------	-----	-----	-------	----

ACO Qmax® 550 with ACO Q-Guard ductile iron edge rail

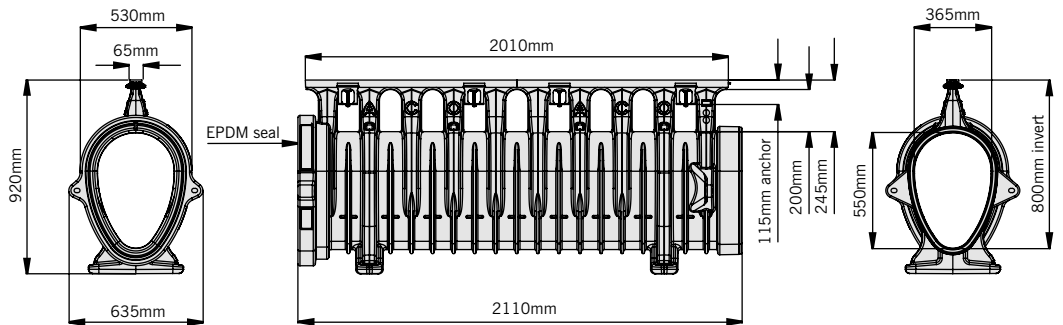

### ACO Qmax® 550 with ACO Q-Flow composite edge rail

32926	ACO Qmax® 550 channel assembly complete with ACO Q-Flow composite edge rail - Black	2010	Ø635	920	25	35.0
-------	---	------	------	-----	----	------

ACO Qmax® 150 with ACO Q-Flow composite edge rail

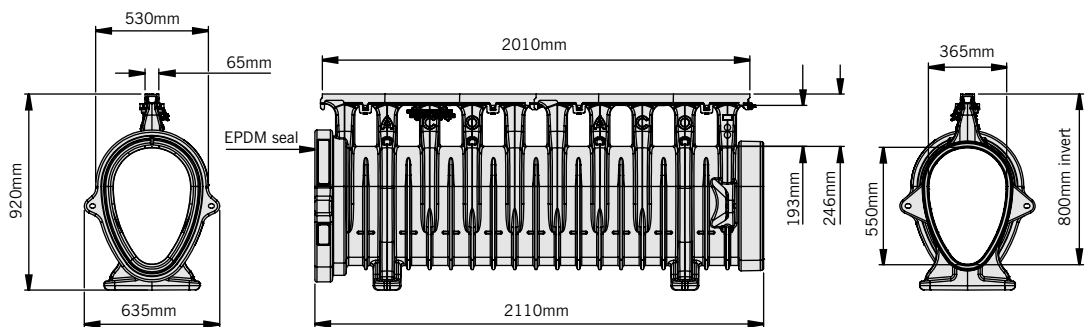



## ACO Qmax® 550

Product Code	Description	Length [mm]	Width overall [mm]	Depth overall [mm]	Slot width [mm]	Weight [kg]
<b>ACO Qmax® 550 with ACO Q-Guard composite edge rail</b>						
32927	ACO Qmax® 550 channel assembly complete with ACO Q-Guard composite edge rail - Black	2010	635	920	9	35.3

ACO Qmax® 550 with ACO Q-Guard composite edge rail

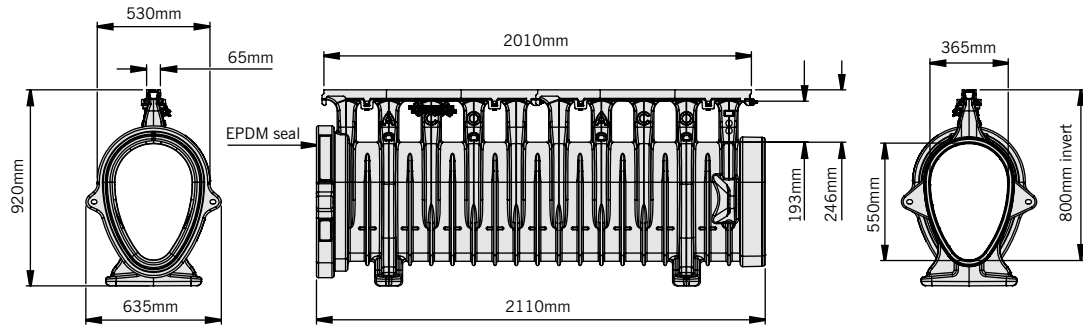
**ACO Qmax® 550 with ACO Q-Flow galvanised steel edge rail**

32822	ACO Qmax® 550 channel assembly complete with ACO Q-Flow galvanised steel edge rail	2010	635	920	26	35.6
-------	--	------	-----	-----	----	------

ACO Qmax® 550 with ACO Q-Flow galvanised steel edge rail

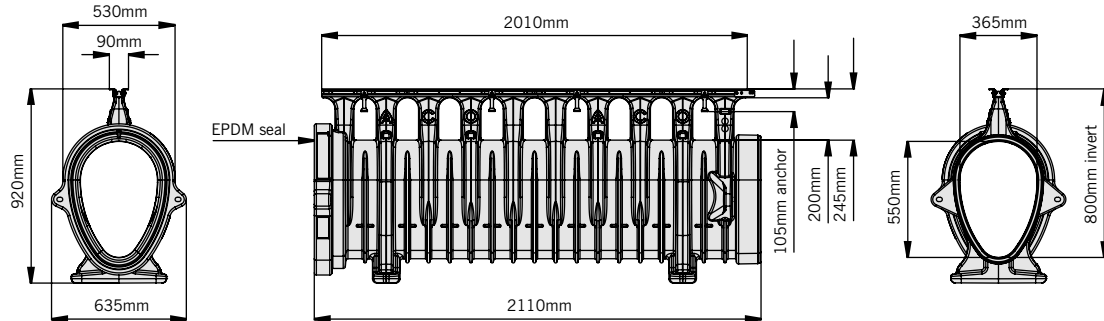
**ACO Qmax® 550 with ACO Q-Guard galvanised steel edge rail**

32823	ACO Qmax® 550 channel assembly complete with ACO Q-Guard galvanised steel edge rail	2010	635	920	10	33.1
-------	---	------	-----	-----	----	------

ACO Qmax® 550 with ACO Q-Guard galvanised steel edge rail

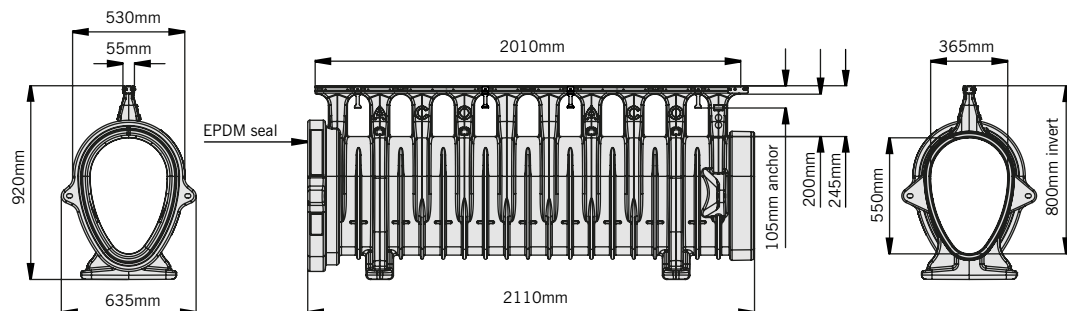

Note: For details regarding the access/silt chambers for use with this system please refer to page 51. These products are subject to weight and dimensional tolerances. The dimensions shown on this page are for guidance purposes only.

# ACO Qmax® 550

Product Code	Description	Length [mm]	Width overall [mm]	Depth overall [mm]	Slot width [mm]	Weight [kg]
--------------	-------------	-------------	--------------------	--------------------	-----------------	-------------

**ACO Qmax® 550 with ACO Q-Slot galvanised steel edge rail**

32824	ACO Qmax® 550 channel assembly complete with ACO Q-Slot galvanised steel edge rail	2010	635	1020	10	40.7
-------	--	------	-----	------	----	------

ACO Qmax® 550 with ACO Q-Slot galvanised steel edge rail

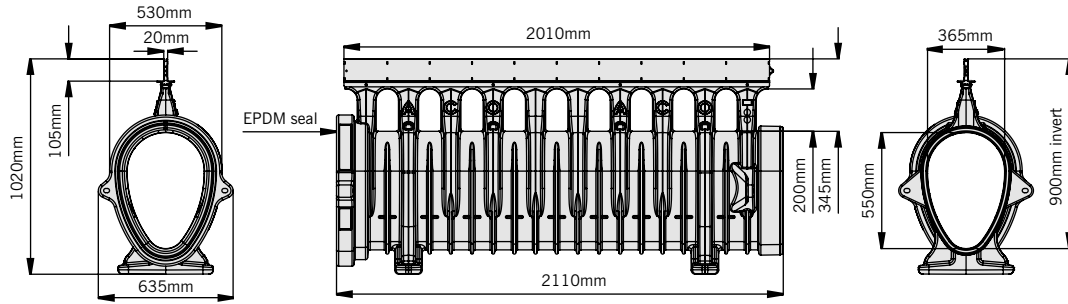

Product Code	Description	Length [mm]	Width overall [mm]	Depth overall [mm]	Weight [kg]
--------------	-------------	-------------	--------------------	--------------------	-------------

**ACO Qmax® 550 closing end cap**

32825	ACO Qmax® 550 closing end cap	635	12	715	3.5
-------	-------------------------------	-----	----	-----	-----

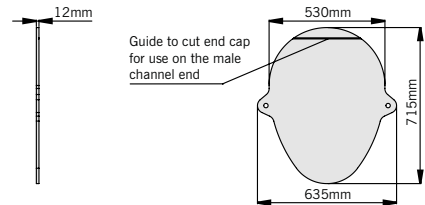

ACO Qmax® 550 closing end cap

Product Code	Description	Length [mm]	Width overall [mm]	Depth overall [mm]	Weight [kg]
--------------	-------------	-------------	--------------------	--------------------	-------------

**ACO Qmax® 550 blanking end cap**

32886	ACO Qmax® 550 blanking end cap	440	60	625	2.1
-------	--------------------------------	-----	----	-----	-----

ACO Qmax® 550 blanking end cap

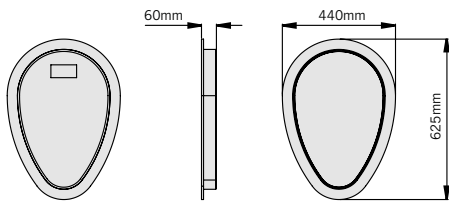

ACO Qmax® 550 blanking end cap has the following functions:

- Enables cut channels to be capped off if cut to length during installation
- Simple fitting

**ACO Qmax® 550 to 700 step connector**

32882	ACO Qmax® 550 to 700 step connector (M to F)	730	75	865	2.5
-------	--	-----	----	-----	-----

ACO Qmax® 550 to 700 step connector

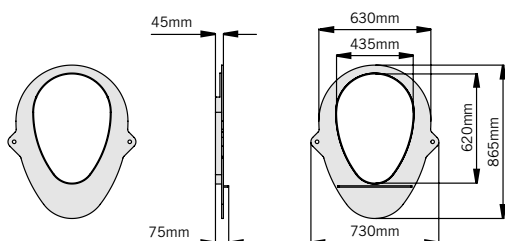

ACO Qmax® 550 to 700 step connector has the following functions:

- Enables step fall installations of ACO Qmax® 550 and ACO Qmax® 700 channels
- For use between ACO Qmax® 550 male and ACO Qmax® 700 female channel connection
- Simple fitting

## ACO Qmax® 550

Product Code	Description	Weight [kg]
32826	ACO Qmax® 550 chamber connector assembly (pair)	11.8

## ACO Qmax® 550 chamber connectors

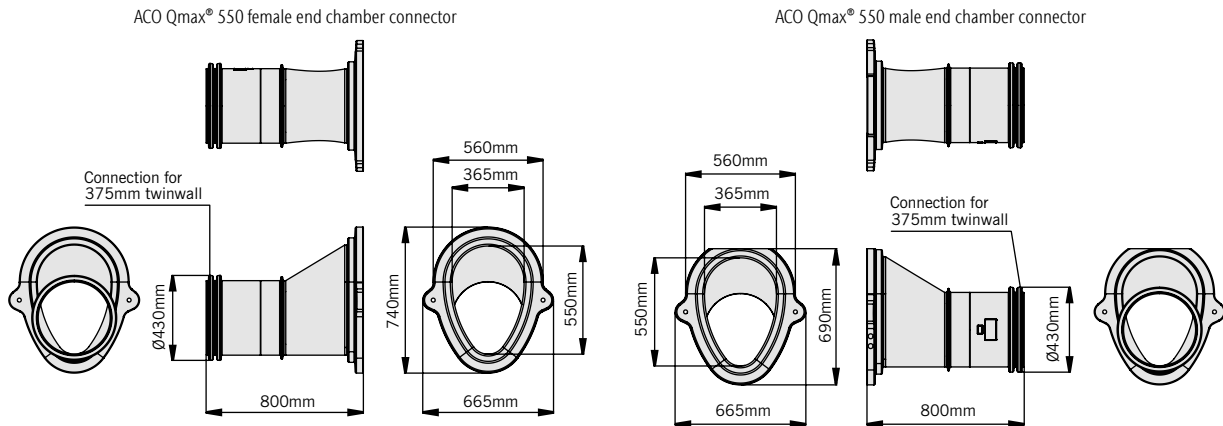

Product Code	Description	Length [mm]	Width overall [mm]	Depth overall [mm]	Weight [kg]
44345	ACO Qmax® 550 downpipe connector Ø160mm outlet	120	178	197	0.16

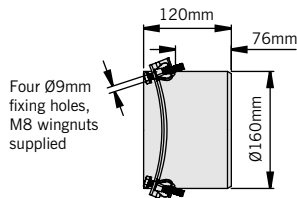

ACO Qmax® 550 downpipe connector has the following functions:

- Allows the connection of rain water pipes into the body of Qmax channels
- Simple fitting

## ACO Qmax® ductile iron edge rail protector

32854	ACO Qmax® ductile iron edge rail protector 15.25m roll	15.25	65	1.5	5.0
-------	--	-------	----	-----	-----

ACO Qmax® ductile iron edge rail protector has the following functions:

- Used to cover and protect rails from debris during installation
- Simple fitting
- Can be reused

# ACO Qmax® 700





The ACO Qmax® 700 channel manufactured from Polyethylene (PE), with recycled material which is lightweight, chemically resistant and extremely robust. Its ovoid High-Flow bore, sealed push fit channel connections and unique patented inlet design ensure efficient drainage even at low hydraulic flows and promote self cleansing. Installation rates are maximised and the product is fully integrated within the pavement detail providing long term dependable performance. The increased hydraulic capacity of the ACO Qmax® 700 channel makes it ideal for larger catchments and can eliminate the need for additional carrier drains and pipework.

ACO Qmax® 700 channels are available with the following components:

- Outlet, closing and blanking end caps
- Qmax 700-900 step connector
- Access and silt chambers
- Installation edge rail protectors
- Q-Brake Vortex flow controls



700	Unit
	Hydraulic capacity
16600m <sup>2</sup>	Catchment area*
0.2501m <sup>3</sup> /m	Attenuation capacity
	Access/outlet/inlet/silt chambers
	Q-slot access chamber, cover and frame

\* Catchment area. Example run based on 100m length laid level at 50mm/hr rainfall.

# ACO Qmax® 700

Product Code	Description	Length [mm]	Width overall [mm]	Depth overall [mm]	Slot width [mm]	Weight [kg]
--------------	-------------	-------------	--------------------	--------------------	-----------------	-------------

### ACO Qmax® 700 with ACO Q-Flow ductile iron edge rail

32830	ACO Qmax® 700 channel assembly complete with ACO Q-Flow ductile iron edge rail	2010	730	1070	26	49.7
-------	--	------	-----	------	----	------

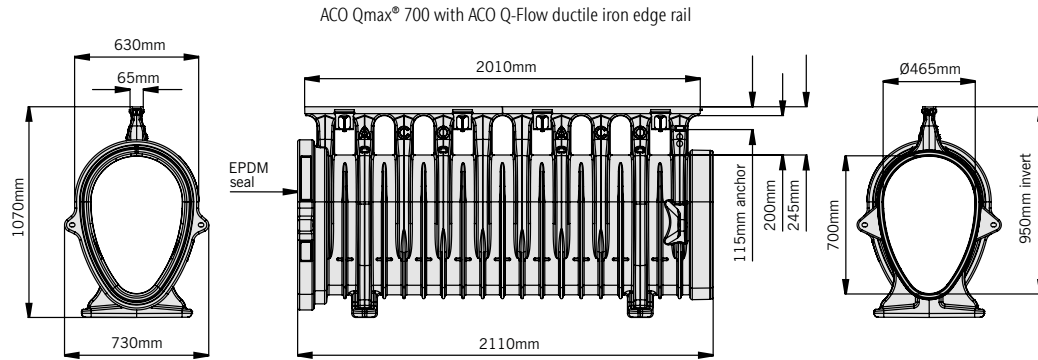

### ACO Qmax® 700 with ACO Q-Guard ductile iron edge rail

32831	ACO Qmax® 700 channel assembly complete with ACO Q-Guard ductile iron edge rail	2010	730	1070	2 x 8	50.7
-------	---	------	-----	------	-------	------

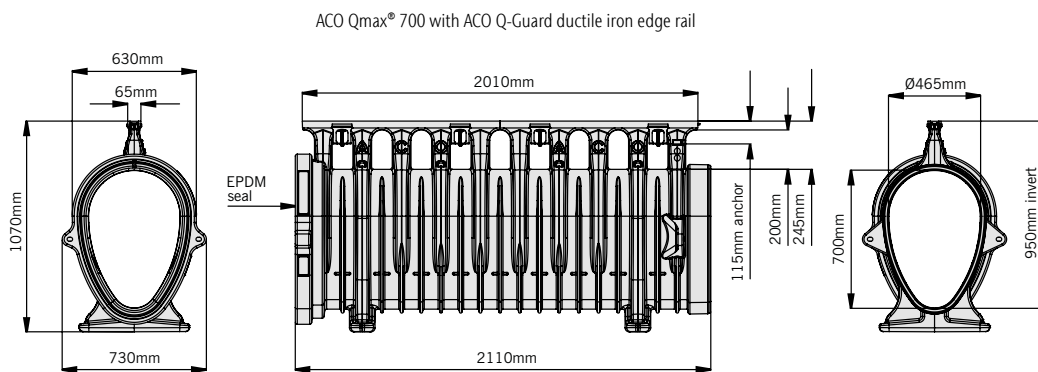

### ACO Qmax® 700 with ACO Q-Flow composite edge rail

32935	ACO Qmax® 700 channel assembly complete with ACO Q-Flow composite edge rail - Black	2010	730	1070	25	41.5
-------	---	------	-----	------	----	------

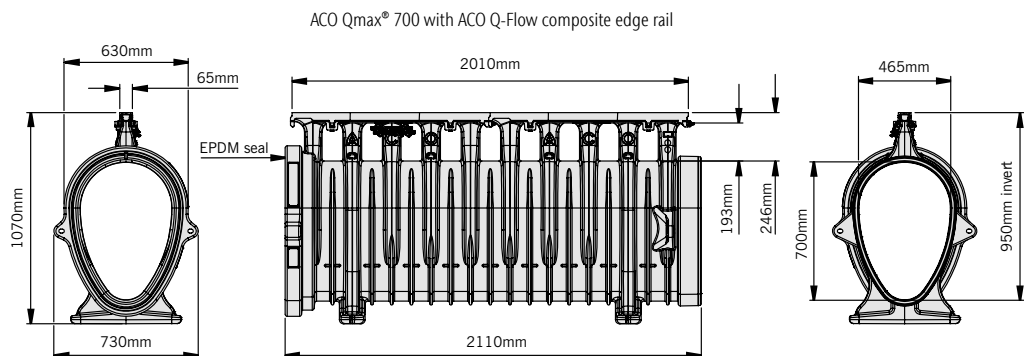

Note: For details regarding the access/silt chambers for use with this system please refer to page 63. These products are subject to weight and dimensional tolerances. The dimensions shown on this page are for guidance purposes only.



# ACO Qmax® 700

Product Code	Description	Length [mm]	Width overall [mm]	Depth overall [mm]	Slot width [mm]	Weight [kg]
--------------	-------------	-------------	--------------------	--------------------	-----------------	-------------

**ACO Qmax® 700 with ACO Q-Guard composite edge rail**

32936	ACO Qmax® 700 channel assembly complete with ACO Q-Guard composite edge rail - Black	2010	730	1070	9	41.8
-------	--	------	-----	------	---	------

ACO Qmax® 700 with ACO Q-Guard composite edge rail

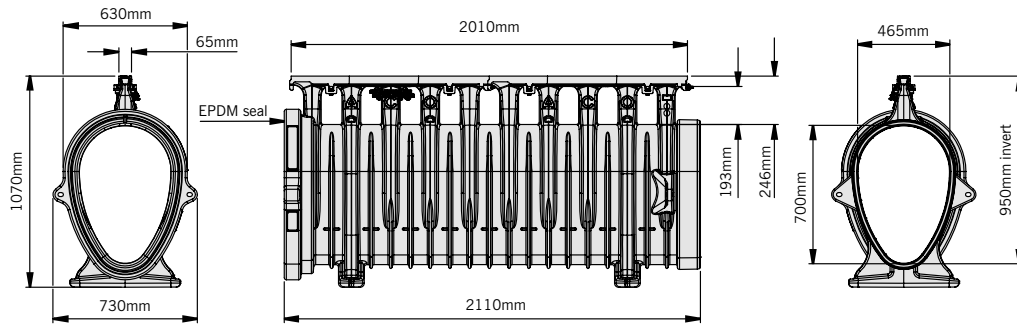

**ACO Qmax® 700 with ACO Q-Flow galvanised steel edge rail**

32832	ACO Qmax® 700 channel assembly complete with ACO Q-Flow galvanised steel edge rail	2010	730	1070	26	41.9
-------	--	------	-----	------	----	------

ACO Qmax® 700 with ACO Q-Flow galvanised steel edge rail

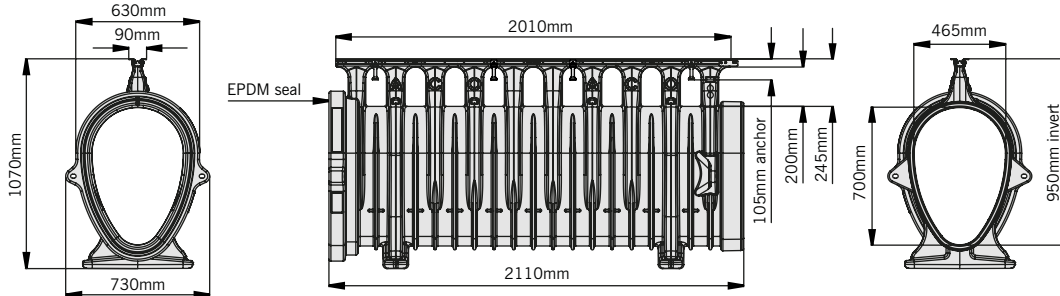

**ACO Qmax® 700 with ACO Q-Guard galvanised steel edge rail**

32833	ACO Qmax® 700 channel assembly complete with ACO Q-Guard galvanised steel edge rail	2010	730	1070	10	39.4
-------	---	------	-----	------	----	------

ACO Qmax® 700 with ACO Q-Guard galvanised steel edge rail

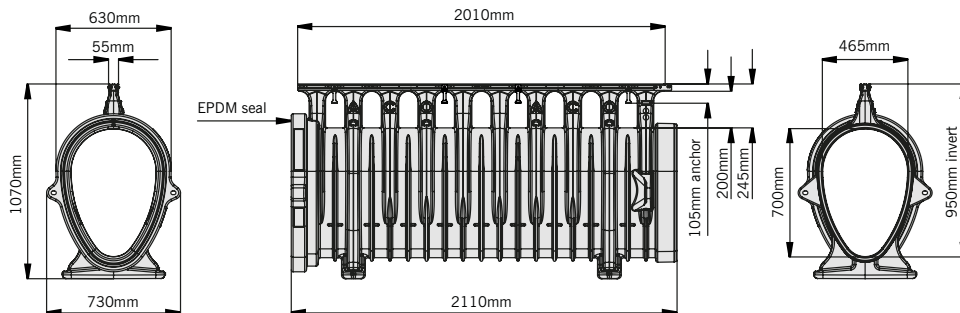

# ACO Qmax® 700

Product Code	Description	Length [mm]	Width overall [mm]	Depth overall [mm]	Slot width [mm]	Weight [kg]
--------------	-------------	-------------	--------------------	--------------------	-----------------	-------------

## ACO Qmax® 700 with ACO Q-Slot galvanised steel edge rail

32834	ACO Qmax® 700 channel assembly complete with ACO Q-Slot galvanised steel edge rail	2010	730	1170	10	47.0
-------	--	------	-----	------	----	------

ACO Qmax® 700 with ACO Q-Slot galvanised steel edge rail

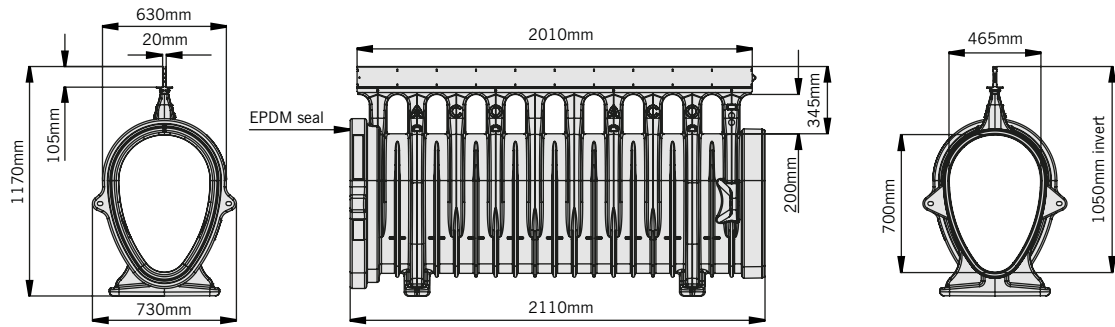

Product Code	Description	Length [mm]	Width overall [mm]	Depth overall [mm]	Weight [kg]
--------------	-------------	-------------	--------------------	--------------------	-------------

## ACO Qmax® 700 closing end cap

32835	ACO Qmax® 700 closing end cap	730	12	865	4.9
-------	-------------------------------	-----	----	-----	-----

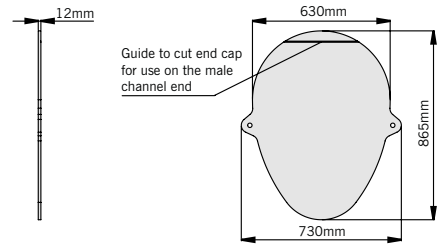

ACO Qmax® 700 closing end cap

Product Code	Description	Length [mm]	Width overall [mm]	Depth overall [mm]	Weight [kg]
--------------	-------------	-------------	--------------------	--------------------	-------------

## ACO Qmax® 700 blanking end cap

32887	ACO Qmax® 700 blanking end cap	540	60	770	3.1
-------	--------------------------------	-----	----	-----	-----

ACO Qmax® 700 blanking end cap

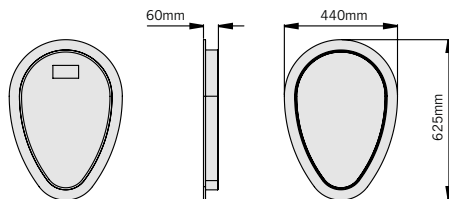

ACO Qmax® 700 blanking end cap has the following functions:

- Enables cut channels to be capped off if cut to length during installation
- Simple fitting

## ACO Qmax® 700

Product Code	Description	Weight [kg]			
<b>ACO Qmax® 700 to 900 step connector</b>					
32883	ACO Qmax® 700 to 900 step connector (M to F)	860	95	1065	3.7

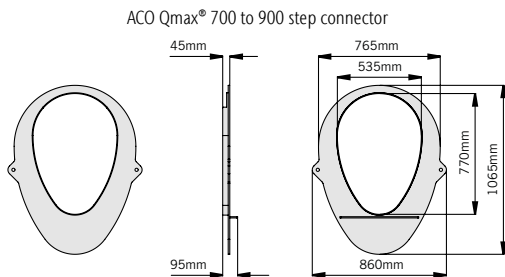

ACO Qmax® 700 to 900 step connector has the following functions:

- Enables step fall installations of ACO Qmax® 700 and ACO Qmax® 900 channels
- For use between ACO Qmax® 700 male and ACO Qmax® 900 female channel connection
- Simple fitting

### ACO Qmax® 700 chamber connectors

32836	ACO Qmax® 700 chamber connector assembly (pair)	15.8
-------	---	------

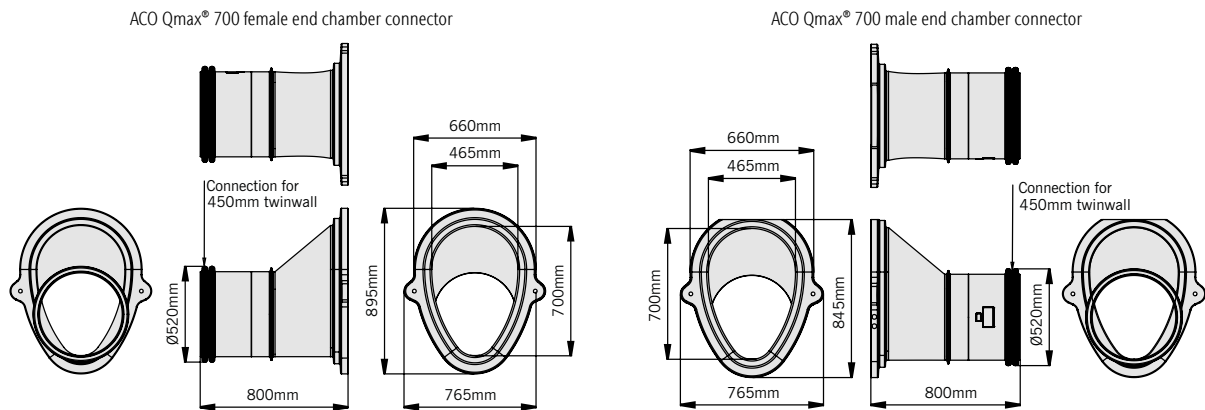

Product Code	Description	Length [mm]	Width overall [mm]	Depth overall [mm]	Weight [kg]
--------------	-------------	-------------	--------------------	--------------------	-------------

### ACO Qmax® 700 downpipe connector

44345	ACO Qmax® 700 downpipe connector Ø160mm outlet	120	178	197	0.16
-------	--	-----	-----	-----	------

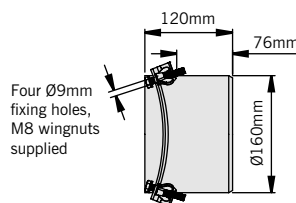

ACO Qmax® 700 downpipe connector has the following functions:

- Allows the connection of rain water pipes into the body of Qmax channels
- Simple fitting

### ACO Qmax® ductile iron edge rail protector

32854	ACO Qmax® ductile iron edge rail protector 15.25m roll	15.25	65	1.5	5.0
-------	--	-------	----	-----	-----

ACO Qmax® ductile iron edge rail protector has the following functions:

- Used to cover and protect rails from debris during installation
- Simple fitting
- Can be reused

These products are subject to weight and dimensional tolerances. The dimensions shown on this page are for guidance purposes only.

# ACO Qmax® 900





The ACO Qmax® 900 channel manufactured from Polyethylene (PE), with recycled material which is lightweight, chemically resistant and extremely robust. Its ovoid High-Flow bore, sealed push fit channel connections and unique patented inlet design ensure efficient drainage even at low hydraulic flows and promote self cleansing. Installation rates are maximised and the product is fully integrated within the pavement detail providing long term dependable performance. The increased hydraulic capacity of the ACO Qmax® 900 channel makes it ideal for larger catchments and can eliminate the need for additional carrier drains and pipework.

ACO Qmax® 900 channels are available with the following components:

- Outlet, closing and blanking end caps
- Access and silt chambers
- Installation edge rail protectors
- Q-Brake Vortex flow controls



900	Unit
	Hydraulic capacity
31700m <sup>2</sup>	Catchment area*
0.4135m <sup>3</sup> /m	Attenuation capacity
	Access/outlet/inlet/silt chambers
	Q-slot access chamber, cover and frame

\* Catchment area. Example run based on 100m length laid level at 50mm/hr rainfall.

# ACO Qmax® 900

Product Code	Description	Length [mm]	Width overall [mm]	Depth overall [mm]	Slot width [mm]	Weight [kg]
--------------	-------------	-------------	--------------------	--------------------	-----------------	-------------

### ACO Qmax® 900 with ACO Q-Flow ductile iron edge rail

32840	ACO Qmax® 900 channel assembly complete with ACO Q-Flow ductile iron edge rail	2010	860	1270	26	65.3
-------	--	------	-----	------	----	------

ACO Qmax® 900 with ACO Q-Flow ductile iron edge rail

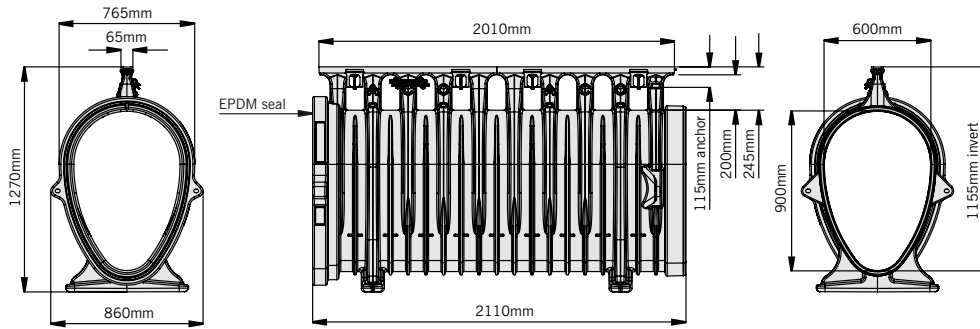

### ACO Qmax® 900 with ACO Q-Guard ductile iron edge rail

32841	ACO Qmax® 900 channel assembly complete with ACO Q-Guard ductile iron edge rail	2010	860	1270	2 x 8	66.3
-------	---	------	-----	------	-------	------

ACO Qmax® 900 with ACO Q-Guard ductile iron edge rail

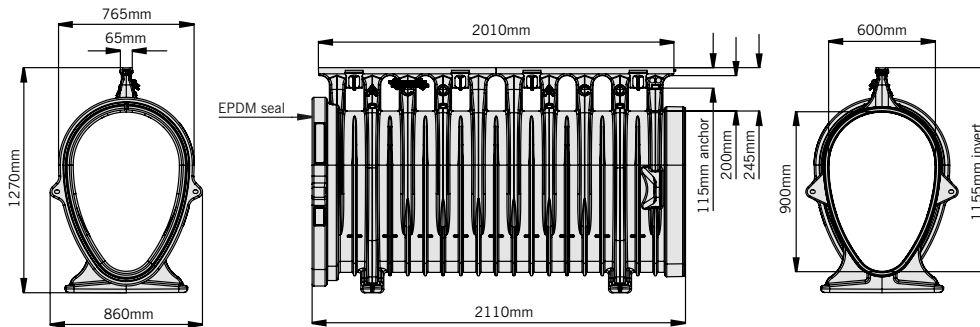

### ACO Qmax® 900 with ACO Q-Flow composite edge rail

32945	ACO Qmax® 900 channel assembly complete with ACO Q-Flow composite edge rail - Black	2010	Ø860	1270	25	57.8
-------	---	------	------	------	----	------

ACO Qmax® 900 with ACO Q-Flow composite edge rail

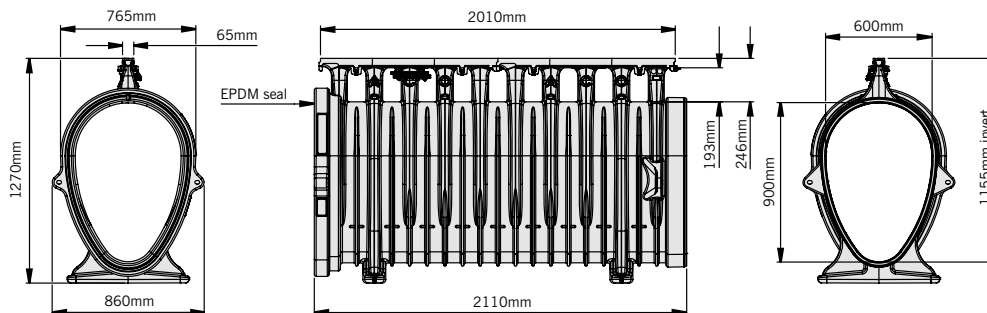



# ACO Qmax® 900

Product Code	Description	Length [mm]	Width overall [mm]	Depth overall [mm]	Slot width [mm]	Weight [kg]
--------------	-------------	-------------	--------------------	--------------------	-----------------	-------------

**ACO Qmax® 900 with ACO Q-Guard composite edge rail**

32946	ACO Qmax® 900 channel assembly complete with ACO Q-Guard composite edge rail - Black	2010	860	1270	9	58.1
-------	--	------	-----	------	---	------

ACO Qmax® 900 with ACO Q-Guard composite edge rail

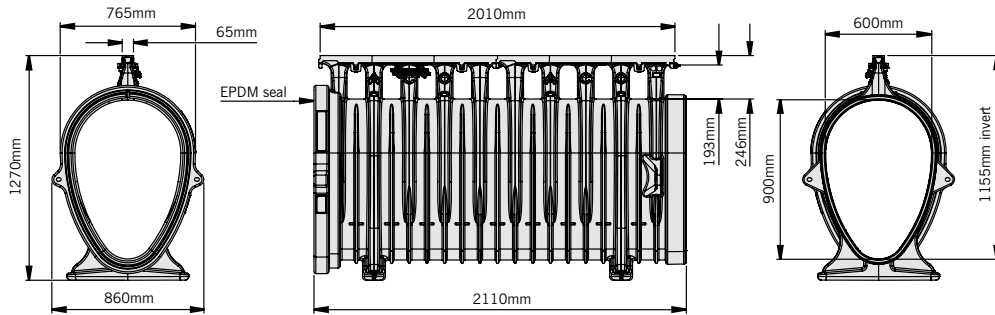

**ACO Qmax® 900 with ACO Q-Flow galvanised steel edge rail**

32842	ACO Qmax® 900 channel assembly complete with ACO Q-Flow galvanised steel edge rail	2010	860	1270	26	57.2
-------	--	------	-----	------	----	------

ACO Qmax® 900 with ACO Q-Flow galvanised steel edge rail

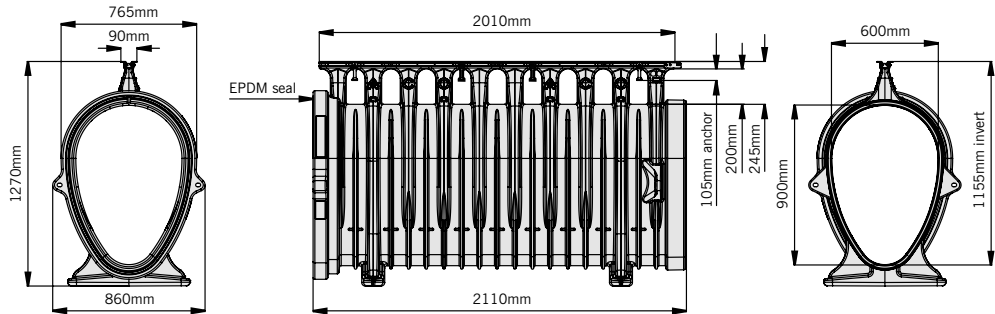

**ACO Qmax® 900 with ACO Q-Guard galvanised steel edge rail**

32843	ACO Qmax® 900 channel assembly complete with ACO Q-Guard galvanised steel edge rail	2010	860	1270	10	54.7
-------	---	------	-----	------	----	------

ACO Qmax® 900 with ACO Q-Guard galvanised steel edge rail

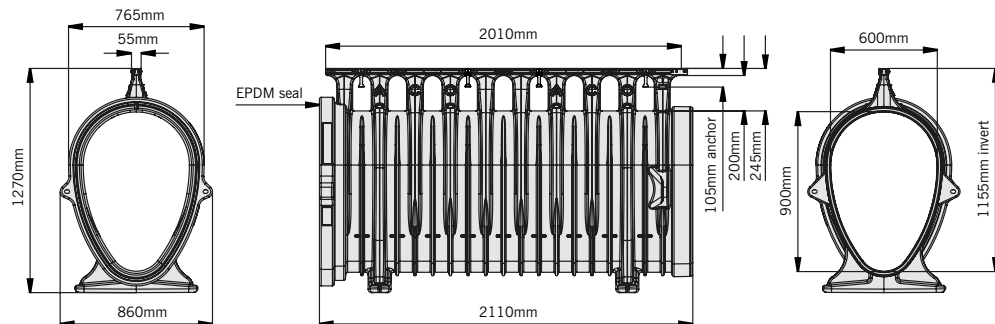

Note: For details regarding the access/silt chambers for use with this system please refer to page 63. These products are subject to weight and dimensional tolerances. The dimensions shown on this page are for guidance purposes only.

## ACO Qmax® 900

Product Code	Description	Length [mm]	Width overall [mm]	Depth overall [mm]	Slot width [mm]	Weight [kg]
--------------	-------------	-------------	--------------------	--------------------	-----------------	-------------

### ACO Qmax® 900 with ACO Q-Slot galvanised steel edge rail

32844	ACO Qmax® 900 channel assembly complete with ACO Q-Slot galvanised steel edge rail	2010	860	1370	10	62.3
-------	--	------	-----	------	----	------

ACO Qmax® 900 with ACO Q-Slot galvanised steel edge rail

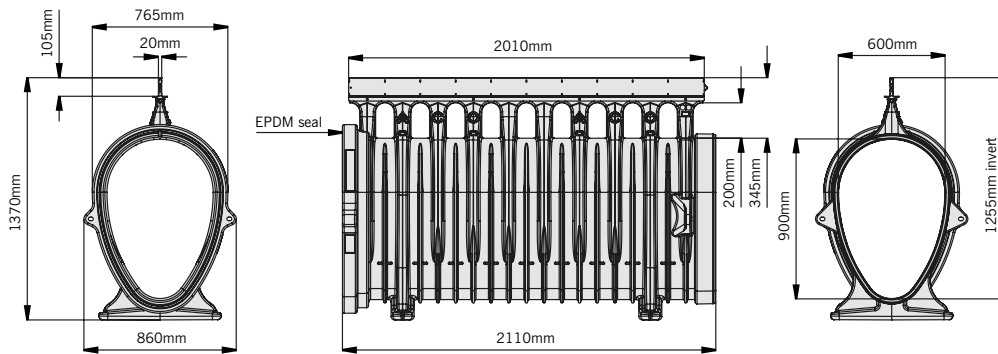

Product Code	Description	Length [mm]	Width overall [mm]	Depth overall [mm]	Weight [kg]
--------------	-------------	-------------	--------------------	--------------------	-------------

### ACO Qmax® 900 closing end cap

32845	ACO Qmax® 900 closing end cap	860	16	1065	9.8
-------	-------------------------------	-----	----	------	-----

CO Qmax® 900 closing end cap

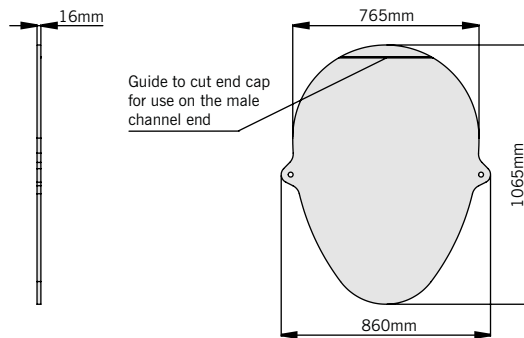

### ACO Qmax® 900 blanking end cap

32888	ACO Qmax® 900 blanking end cap	670	60	970	4.9
-------	--------------------------------	-----	----	-----	-----

ACO Qmax® 900 blanking end cap

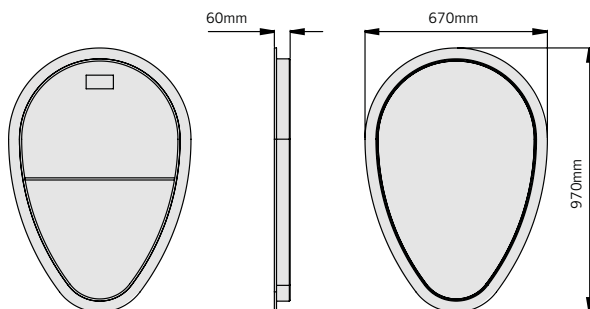

ACO Qmax® 900 blanking end cap has the following functions:

- Enables cut channels to be capped off if cut to length during installation
- Simple fitting

# ACO Qmax® 900

Product Code	Description	Weight [kg]
32846	ACO Qmax® 900 chamber connector assembly (pair)	25.1

## ACO Qmax® 900 chamber connectors

ACO Qmax® 900 female end chamber connector

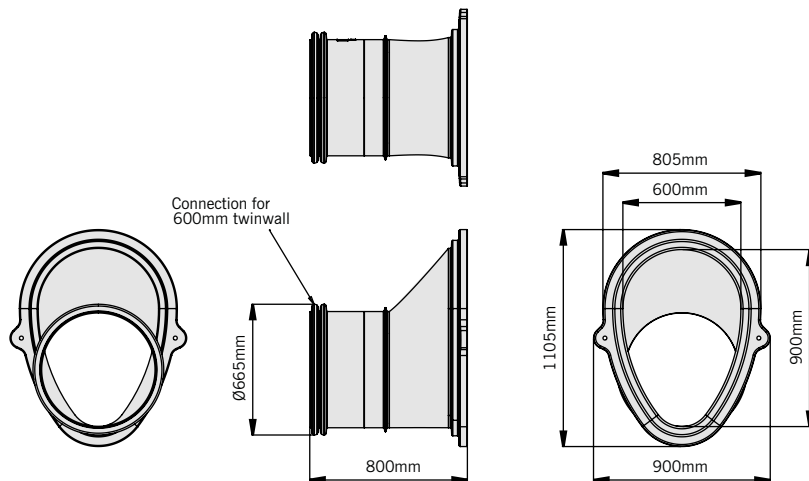

ACO Qmax® 900 male end chamber connector

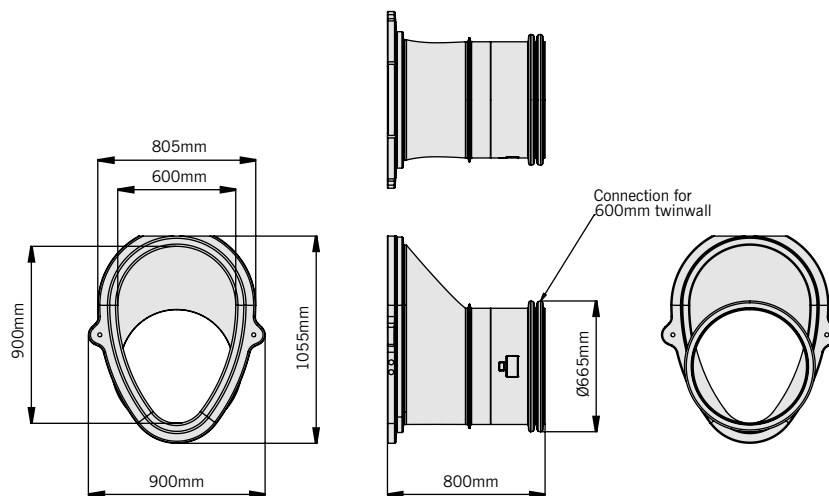

## ACO Qmax® 900

Product Code	Description	Length [mm]	Width overall [mm]	Depth overall [mm]	Weight [kg]
<b>ACO Qmax® 900 downpipe connector</b>					
44345	ACO Qmax® 900 downpipe connector Ø160mm outlet	120	178	197	0.16

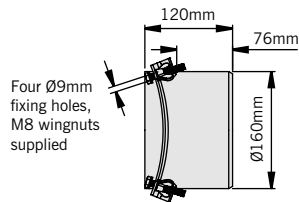

ACO Qmax® 900 downpipe connector has the following functions:

- Allows the connection of rain water pipes into the body of Qmax channels
- Simple fitting

<b>ACO Qmax® ductile iron edge rail protector</b>					
32854	ACO Qmax® ductile iron edge rail protector 15.25m roll	15.25	65	1.5	5.0

ACO Qmax® ductile iron edge rail protector has the following functions:

- Used to cover and protect rails from debris during installation
- Simple fitting
- Can be reused

# ACO Qmax® 550, 700 and 900 access, outlet/inlet and silt chambers

The ACO Qmax® 550, 700 & 900 access and silt chamber provides a compact and economical method of gaining access to the channel system for maintenance and cleaning, or silt management.

The chamber is specifically designed for use with ACO Qmax® 550, 700 and 900 channels and allow 4-way channel connections to be made for simple directional changes and optimised scheme designs.

ACO Qmax® 225 and 350 channel connections are also provided where large silt capacities are required or if all channel sizes are to be connected to the access chamber.

The ACO Qmax® access and silt chamber is manufactured from PE which is lightweight, tough and chemically resistant.

### Cover and frame options

The chambers come complete with either a ductile iron slotted or solid double triangular cover and frame. Both options are available in Load Class D 400 or F 900. As standard all F 900 ductile iron slotted or solid covers are lockable for added product and site security.

Where access and silt chambers are to be used in conjunction with ACO Qmax® Q-slot channels, a recessed cover and frame supplied by others can be used in conjunction with the ACO Qmax® 550, 700 and 900 access and silt chamber bodies. For further details of the chambers supplied without covers and frames, please contact the ACO Water Management Customer Support Team on 01462 816666.

Materials used in the construction of ACO Qmax® chambers contain high levels of recycled materials and are themselves recyclable at the end of their life.



D 400 / F 900 ductile iron slotted cover and frame



D 400 / F900 ductile iron solid cover and frame



Product Code	Description	Length [mm]	Width overall [mm]	Depth overall [mm]	Weight [kg]
--------------	-------------	-------------	--------------------	--------------------	-------------

### ACO Qmax® access chamber assemblies

46114	Access chamber with D 400 slotted cover and frame	760	760	1500	105
46115	Access chamber with D 400 solid cover and frame	760	760	1500	99
46116	Access chamber with F 900 slotted cover and frame	760	760	1500	130
46117	Access chamber with F 900 solid cover and frame	760	760	1500	117

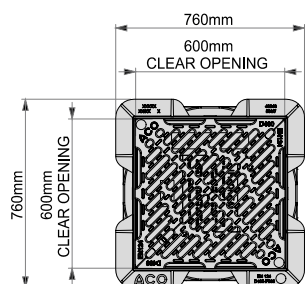

ACO Qmax® 550, 700 and 900 access chamber with slotted cover and frame

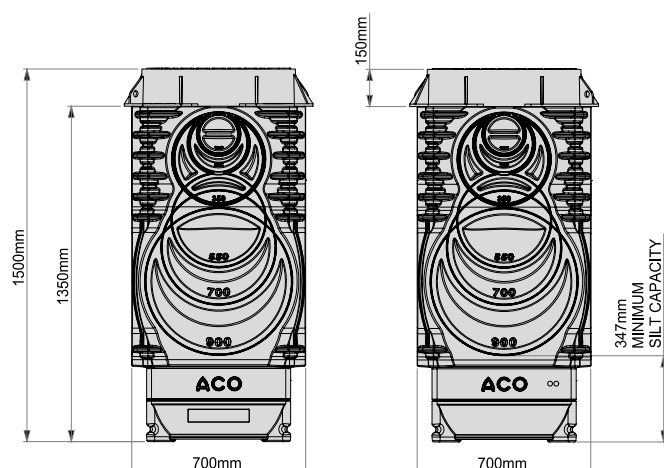

These products are subject to weight and dimensional tolerances. The dimensions shown on this page are for guidance purposes only.



# Controlling stormwater discharge

If a controlled rate discharge is required, ACO Qmax® can be used in conjunction with the ACO Q-Brake Vortex flow control unit to regulate stormwater flows. It provides superior hydraulic performance in comparison to traditional flow control systems and permits more flow at lower heads, reducing storage volume requirements and lowering cost.

Compared with more conventional methods e.g. orifice plates or sized pipework, ACO Q-Brake Vortex is less prone to blockage and permits higher flow at a lower head of water, as a vortex flow control allows an outlet orifice 4-6 times larger in cross-sectional area to be used.

The installation opposite simulates how the ACO Qmax® 900 channel system is used to provide surface water drainage, whilst the ACO Q-Brake Vortex is used to regulate the rate of discharge from the development into the watercourse or sewer network.

The benefits of using this stormwater control system are best demonstrated in the example shown on the opposite page. The example demonstrates that upstream storage requirements can be reduced by 10% when an ACO Q-Brake Vortex flow control is used instead of a traditional flow control system.

## ACO Qmax® channel attenuation storage with a Q-Brake Vortex flow control

### Example

There is a project in Bedford, England with a catchment area of 1200m<sup>2</sup>. The project has design criteria of a 1 in 30 year storm and the runoff from the site must not exceed 3.5l/s at a design head of 0.9m (the height of the ACO Qmax® 900 channel).

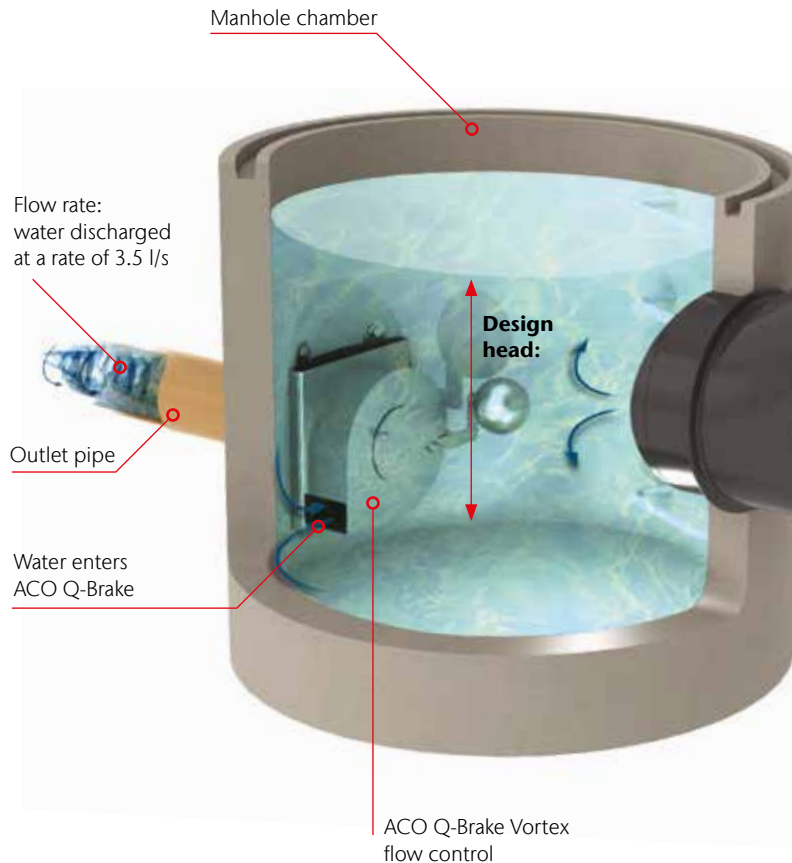

#### ACO Q-Brake Vortex flow control specification and design process

Manufactured from grade 304 stainless steel, each unit is individually configured to suit specific performance criteria. Our engineers will use industry standard drainage software and hydraulic design calculations to ensure the system is correctly sized for any project requirement.

For more information on Q-Brake Vortex flow control go to [www.aco.co.uk/products/q-brake-vortex](http://www.aco.co.uk/products/q-brake-vortex)

## Results

Using drainage software, ACO has compared the upstream storage requirements using ACO Q-Brake Vortex flow control and a traditional orifice plate. The results are summarised below:

- ACO Q-Brake Vortex flow control required Ø84mm. Upstream attenuation requirement met by 50m ACO Qmax® 900.
- Orifice plate size required Ø41mm. Upstream attenuation requires 55m of ACO Qmax® 900.

ACO Q-Brake Vortex flow control reduces the requirement for attenuation whilst having an orifice over four times the area of the traditional orifice plate and making it more efficient and far less prone to blockage.

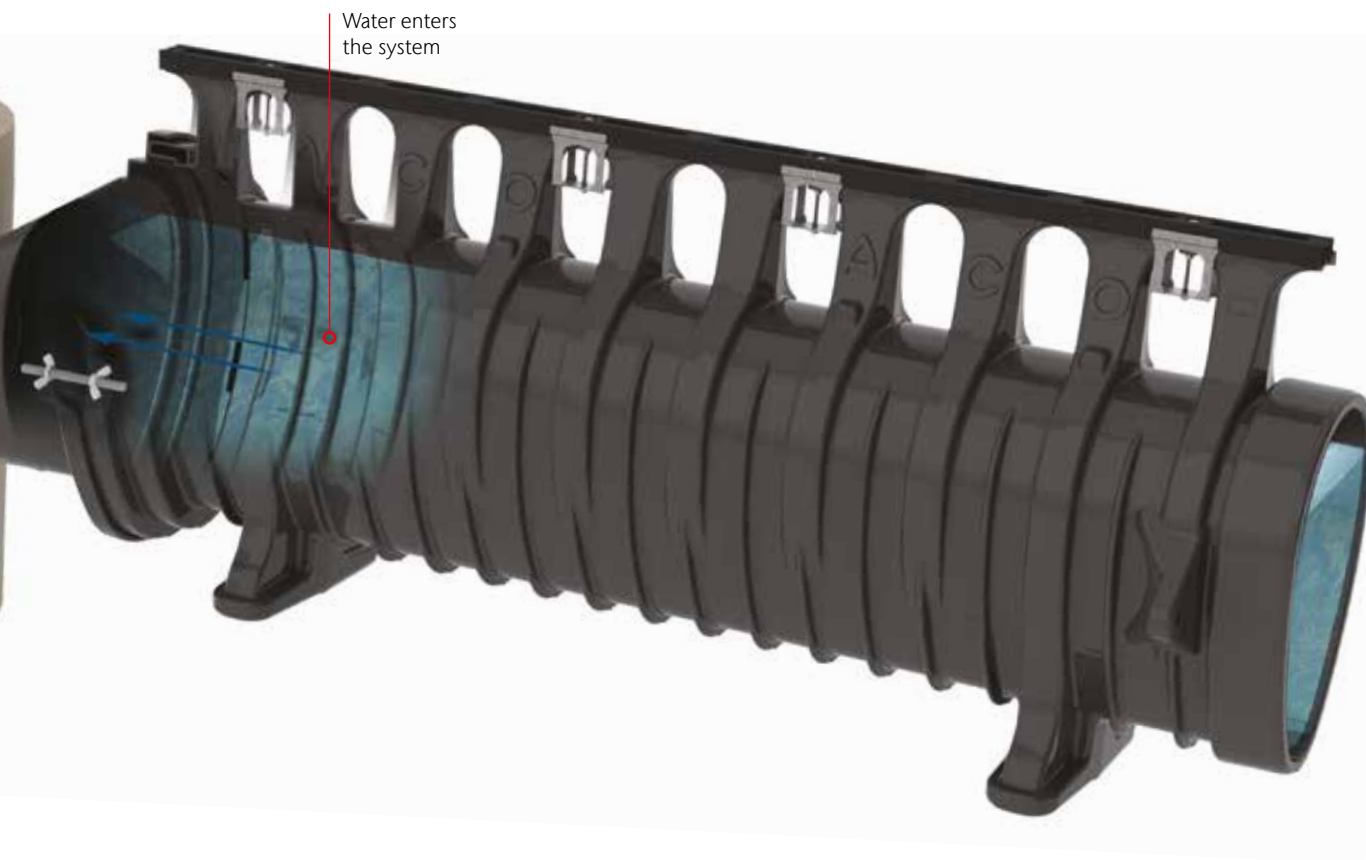
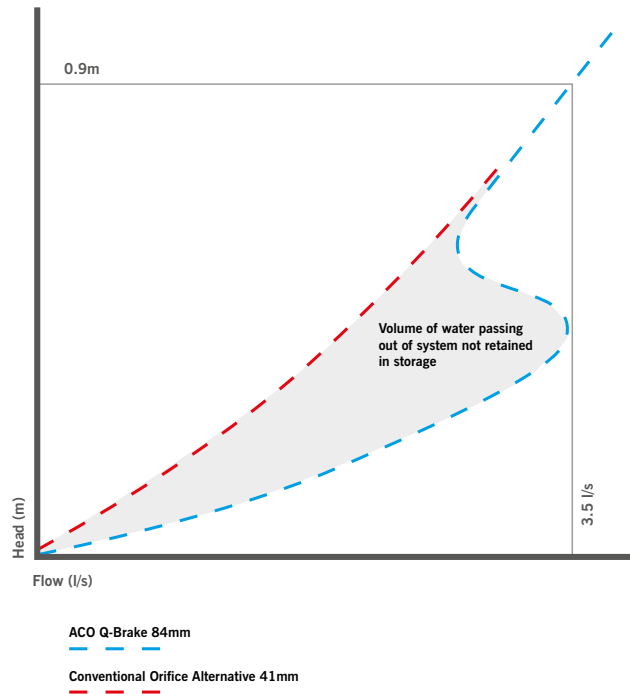

## Design support services

Surface water management system design can often be a complex task. Success in combining products and processes requires a thorough understanding of how these different elements work together.

The ACO Design Services Team is able to work closely with you through the entire design process to ensure accurate and cost-effective product selection is made.

Services we offer include (free and without obligation):

- Whole system design, from collection to the attenuation of surface water
- Hydraulic calculations and AutoCAD detailing
- Parts schedules
- Conduit files for MicroDrainage

ACO has embraced the concept of value engineering as an approach to on-site construction that saves both time and money.

ACO will review any design to minimise the total scheme and life cost of a proposal. The team can suggest the most appropriate range depending on your requirements.

Some ranges like MultiDrain or MonoDrain allow water to be contained and conveyed close to the surface, which accords with the principles advocated for Sustainable Drainage (SuDS Manual, 2015), by removing the need for pumping. Other ranges like Qmax allow attenuation – the storage of large volumes of water during storm events, reducing overall site costs.

For detailed designs using the ACO Hydraulic Design Software, please contact the ACO Water Management Design Services Team.

If manual calculations are preferred to using our QUAD software, hydraulic tables and instructions for manual calculations can be provided.

For design enquiries go to [www.aco.co.uk/design-+-support-services](http://www.aco.co.uk/design-+-support-services)





## ACO BIM Models

BIM is the process of generating and managing data, and developing collaborative behaviours that will unlock new and more efficient ways of working at all stages of the project life-cycle.

These files will help contractors specify and optimise drainage systems in line with the overall benefits of BIM-enabled working, including faster project delivery,

reduced costs, reduced waste and greater project predictability.

Depending on the product range Civils3D, IFC or Revit files are available for download.

**[www.aco.co.uk/aco-bim-models](http://www.aco.co.uk/aco-bim-models)**



# Chemical resistance chart

ACO Qmax® is manufactured from PE and has a high resistance to dilute acids, alkalis, and is unaffected by road salt, fuel, oil, de-icing agents and other commonly encountered chemicals. Further details of the chemical resistance can be obtained from the ACO Water Management Design Services Team or for particular chemicals, samples of PE can be supplied to customers for their own testing. The chemical resistance will also depend on the temperature of the effluent.

The resistance of the gratings and edge rails should also be considered. This chemical resistance chart refers to chemical at ambient temperatures (20°C) and the results are for general guidance only.

## Important considerations for chemical environments.

When reviewing potential applications for ACO Qmax® in chemical environments, the following issues should be considered:

- Type(s) & mixture of chemical(s)
- Concentration percentages
- Contact time with drainage system
- Temperatures of chemicals flowing into the drainage system (80°C max)
- Flushing system employed to clear chemicals from the drainage system
- Cleaning agents should be checked for compatibility with channel materials
- ACO material samples can be used for final determination of chemical resistance
- Edge rails, seals, access and silt chamber materials should be checked for chemical resistance

Chemical medium	% conc	Resistance: Polyethylene
Acetic acid, glacial	Greater than 96%	YES
Acetic acid	10% - 100%	YES
Acetic anhydride	100%	YES
Acetone	100%	YES
Alum	SOL	YES
Aluminium Sulphate	SAT SOL	YES
Ammonium Chloride	SAT SOL	YES
Ammonium Nitrate	SAT SOL	YES
Ammonium Phosphate	SAT SOL	YES
Ammonium Sulphate	SAT SOL	YES
Aniline (aminobenzene)	100%	YES
Barium Chloride	SAT SOL	YES
Benzaldehyde	100%	YES
Benzene	100%	Limited
Benzyl Alcohol	100%	YES
Borax	SAT SOL	YES
Boric Acid	SAT SOL	YES
Bromine	100%	NO
Bromine Water	100%	NO
Butyl Acetate	100%	YES
Butyric acid	100%	YES
Calcium Carbonate	SAT SOL	YES
Calcium Chloride	SAT SOL	YES
Calcium Hydroxide	SAT SOL	YES
Calcium Nitrate	SAT SOL	YES
Carbon Disulphide	100%	Limited
Carbon Tetrachloride	100%	Limited
Castor Oil	SOL	YES
Chlorine Gas, wet	100%	Limited
Chlorine Water	2% SAT SOL	YES
Chlorobenzene	100%	NO
Chloroform	100%	NO
Chromic Acid	50%	YES
Citric Acid	SAT SOL	YES
Citric Acid	20%	YES

Chemical medium	% conc	Resistance: Polyethylene
Citric Acid	50%	YES
Copper Chloride	SAT SOL	YES
Copper Nitrate	SAT SOL	YES
Diesel (DERV)	100%	YES
Dimethyl Formamide	100%	YES
Dicotyl Phthalate	100%	YES
Ethanol	40%	YES
Ethanol	96%	YES
Ethyl Acetate	100%	YES
Ethylene Glycol	100%	YES
Ferric Chloride	SAT SOL	YES
Ferrous Chloride	SAT SOL	YES
Ferrous Sulphate	SAT SOL	YES
Formaldehyde	40%	YES
Formic Acid	40%	YES
Fuel Oil	100%	YES
Glycerine	100%	YES
Hydrobromic Acid	100%	YES
Hydrochloric Acid	Concentrate	YES
Hydrofluoric Acid	Concentrate	YES
Hydrogen Peroxide	30-90%	YES
Lactic Acid	100%	YES
Lead Acetate	SAT SOL	YES
Magnesium Chloride	SAT SOL	YES
Magnesium Sulphate	SAT SOL	YES
Maleic Acid	Concentrate	YES
Motor Oil	100%	YES
Nickel Chloride	SAT SOL	YES
Nickel Sulphate	SAT SOL	YES
Nitric Acid	25%	YES
Hydrofluoric Acid	Concentrate	YES
Nitrobenzine	100%	NO
Oleic Acid	100%	YES
Oxalic Acid	100%	YES
Phosphoric Acid	98%	YES
Phosphorous Trichloride	100%	YES
Petrol	100%	Limited

Chemical medium	% conc	Resistance: Polyethylene
Potassium Carbonate	SAT SOL	YES
Potassium Chloride	SAT SOL	YES
Potassium Dichromate	SAT SOL	YES
Potassium Hydroxide	10%	YES
Potassium Nitrate	SAT SOL	YES
Potassium Permanganate	20%	YES
Potassium Sulphate	SAT SOL	YES
Pyridine	100%	YES
Sodium Acetate	SAT SOL	NO
Sodium Bromide	SAT SOL	YES
Sodium Carbonate	SAT SOL	YES
Sodium Chlorate	SAT SOL	YES
Sodium Chloride	SAT SOL	YES
Sodium Hydroxide (Caustic Soda)	Concentrate	YES
Sodium Hypochlorite	15%	YES
Sodium Nitrate	SAT SOL	YES
Sodium Nitrite	SAT SOL	YES
Sodium Phosphate	SAT SOL	YES
Sodium Sulphate	SAT SOL	YES
Sodium Sulphide	SAT SOL	YES
Stearic Acid	SAT SOL	YES
Styrene	SOL	Limited
Sulphuric Acid	10%	YES
Sulphuric Acid	50%	YES
Sulphuric Acid	70%	YES
Sulphuric Acid	80%	YES
Sulphuric Acid	98%	YES
Sulphuric Acid	FUMING	NO
Tetrachloroethylene	100%	NO
Thionyl Chloride	100%	NO
Toluene	100%	Limited
Turpentine	100%	Limited
Water	100%	YES
Xylene	100%	Limited
Zinc Sulphate	SAT SOL	YES



## Model specification clause

The channel drainage system shall be ACO Qmax® supplied by ACO Technologies plc. All materials and components within the scope of the system shall be supplied by this manufacturer. The channel units shall be fully compliant with BS EN 1433:2002 with Initial Type Test certification issued by a notified body independent of the manufacturer.

All units shall be of one piece manufacture in Polyethylene (PE), including recycled material, with metal or composite edge rails attached to the top of the channels.

The standard units shall be installed with the manufacturer's components as required for the scheme. The system shall be installed in accordance with the manufacturer's printed recommendations, and the works carried out as specified on drawings ... ..\* and in accordance with recognised good practice. Standards of workmanship shall generally be as specified in BS EN 752 and BS 8000:Part 14:1989.

\*complete as appropriate

## Recycled content

ACO Technologies aim to incorporate as much recycled material or waste material as is practicable in their manufactured products without compromising performance. Typically Polyethylene (PE) materials contain a maximum of 20% recycled material. This is reground material from the existing process making it a (near) zero waste manufacturing process.

The total recycled content of each product in the ACO Qmax® system will vary as the proportion of different material varies due to the channel size and edge rail material and type. As an example, ACO Qmax® 550 channels with Q-Guard ductile iron edges will contain a minimum of approximately 27% by weight recycled content.

The ACO Qmax® products are themselves intended for long life with low maintenance, to reduce the need to recycle, but when eventually they are no longer needed, their materials can be readily recycled with a very low risk of pollution to the environment.

ACO is actively engaging with its supply chain to change to recycled material without compromising the structural integrity of the product.



The ACO Qmax® system is CE and UKCA marked in accordance with the Construction Products Regulation.

Declarations of Performance are available via the DOP data zone on our website ([www.aco.co.uk/DoP.php](http://www.aco.co.uk/DoP.php)), CPR data on the product page, or on request. Please contact ACO Water Management Design Services Team on 01462 816666 for further assistance.

## BS EN 1433:2002



# Further Learning

## ACO Professional Development

ACO has recognised that knowledge transfer is fundamental in keeping up-to-date with the latest advancements in surface water management and has a unique training offer that can be accessed online, in-house or at the state-of-art training facility at the ACO Academy.

### In Company

ACO offers face-to-face professional development sessions. These are carefully designed to last up to 1 hour, so they can be undertaken across a lunch break.



A member of our team will contact you directly to discuss your requirements and will tailor the session to meet your needs.

### Webinars

ACO has developed a series of webinars that will keep you up to date, bringing you technical expertise as well as more specific product information. Whatever your involvement from specification to installation, there will be a webinar to meet your needs and further your learning.



### ACO Academy Days

ACO's training facility at its UK head office in Bedfordshire has a theatre-style facility that can hold up to 50 people as well as a number of breakout rooms for small groups.



Professional development training can be combined with more in-depth product training at the on-site learning zone.

### Seminars

ACO is bringing the experts to you via our programme of regional events, and by sharing information from key influencers within the industry as well as more specific product information. ACO's seminar events will include opportunities to enhance existing knowledge as well as network and discuss thoughts and ideas with other delegates.



[www.aco.co.uk/professional\\_development](http://www.aco.co.uk/professional_development) | email: [ukprofessionaldevelopment@aco.co.uk](mailto:ukprofessionaldevelopment@aco.co.uk)



ACO has operated in the UK for over 30 years and in this time we have worked on ground breaking projects that have pushed the boundaries of surface water management. Our case studies provide bite sized information that counts towards your professional development and can provide inspiration for future projects.

[www.aco.co.uk/case-studies](http://www.aco.co.uk/case-studies)



Colab is a collaboration of partnerships, bringing together CPD and self-certified content to ensure that knowledge is shared and accessible to the construction industry. Visit our content and CPD partner website: Colab to see more professional development content from partners such as ACO, FutureBuild, CIHT, The Edge, and CIWEM

[www.colab-cpd.co.uk](http://www.colab-cpd.co.uk)



# askACO

train | design | support | care



Every product from ACO Water Management supports the ACO WaterCycle



- 
- ACO Water Management  
Civils + Infrastructure  
House & Garden
  - ACO Building Drainage
  - ACO Access
  - ACO Sport
  - ACO Wildlife
- 

### ACO Water Management

A division of ACO Technologies plc  
ACO Business Park  
Hitchin Road  
Shefford  
Bedfordshire  
SG17 5TE

Tel: 01462 816666  
Sales: [customersupport@aco.co.uk](mailto:customersupport@aco.co.uk)  
Project pricing: [awmprojects@aco.co.uk](mailto:awmprojects@aco.co.uk)  
Technical: [technical@aco.co.uk](mailto:technical@aco.co.uk)

[www.aco.co.uk](http://www.aco.co.uk)

ACO. we care for water

