








A technical diagram of the Xtraline drainage system, showing a cross-section of a U-shaped channel with a curved bottom and a flat top. The diagram is rendered in white lines on a light blue background. A white rectangular box is overlaid on the lower left portion of the diagram, containing the product name 'Xtraline' in red text.

Xtraline

Plastic Drainage Systems

Contents

Plastic drainage solutions

1	ACO Xtraline G	■ Professional plastic channel with ductile iron rail	P. 2	
2	ACO Xtraline B	■ Professional plastic channel with galvanized steel rail and 8 bolt fixing system	P. 18	
3	ACO Xtraline S	■ Professional plastic channel with galvanized/stainless steel rail	P. 32	
4	ACO Xtraline C	■ Professional plastic channel with HD-PE rail	P. 46	
5	ACO Xtraline	■ Professional plastic channel with no rail	P. 64	
6	ACO Xtraline range special parts	■ Special parts for professional plastic channels	P. 77	
7	ACO Easyline	■ Plastic channel with PP-PE rail	P. 78	



1 ACO Xtraline G
Drainage channel

COLLECT:
Collect and convey



ACO Xtraline G – Plastic drainage channels

ACO Xtraline G 100	Channel body	P. 6
	Channel accessories	P. 7
	Sump unit	P. 7
	Gratings	P. 8
ACO Xtraline G 150	Channel body	P. 9
	Channel accessories	P. 10
	Sump unit	P. 10
	Gratings	P. 11
ACO Xtraline G 200	Channel body	P. 12
	Channel accessories	P. 13
	Sump unit	P. 13
	Gratings	P. 14
ACO Xtraline G 300	Channel body	P. 15
	Channel accessories	P. 15
	Gratings	P. 16



Declaration of performance at:
www.aco.it/download/dop-e-certificati/

ACO Xtraline G: The cast iron rail to challenge time

ACO Xtraline G, a full product range of channels designed and produced by ACO, dedicated to industrial areas, that, every day, are experienced by men and heavy vehicles intent on carrying out their fully productive activities.

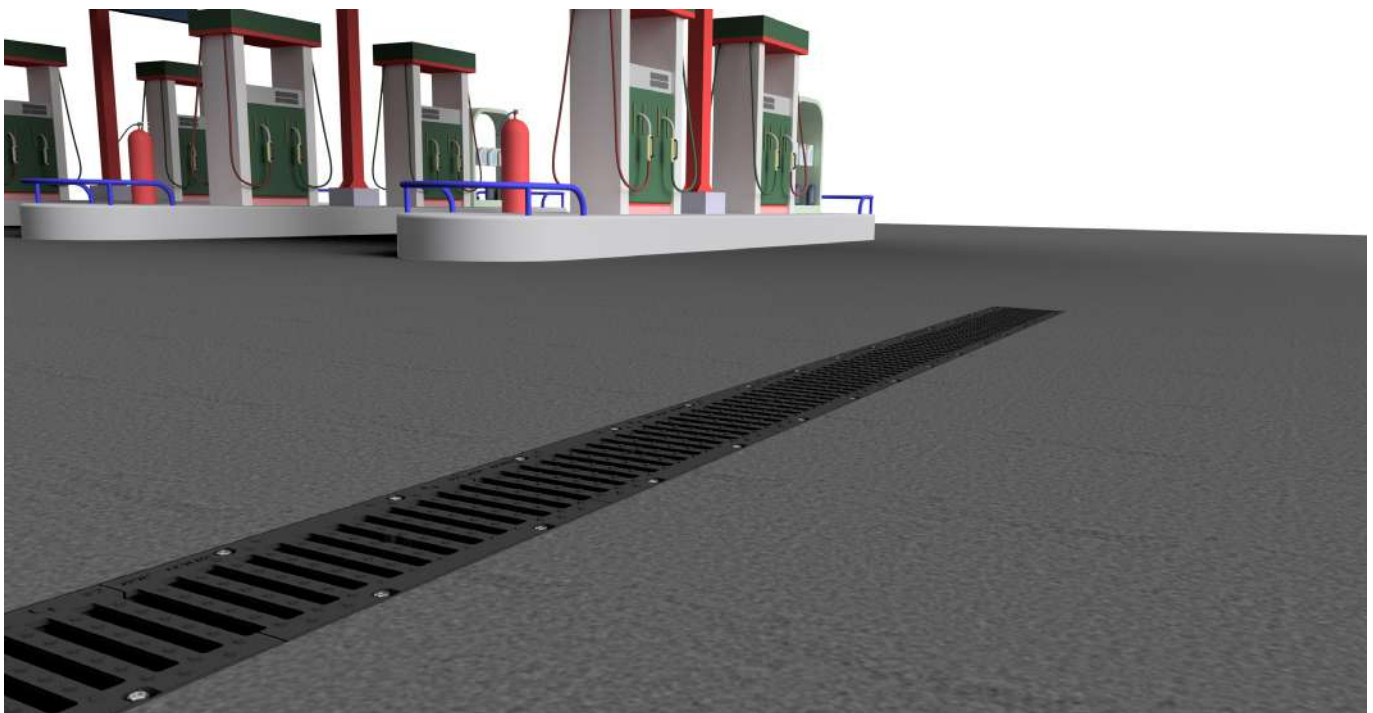
The channel body is completely made of HD-PE and the ductile iron rail is firmly integrated.

The ductile iron rail GJS 500/7 makes the **ACO Xtraline G** unique; in addition to being extremely strong due to its generous thickness (6 mm) in the areas subject to vehicular traffic and in the support area of the grating, it is capable of challenging time with its intrinsic qualities of resistance both to traffic and atmospheric severe conditions.

The complete system is suitable and certified up to load class F 900. Gratings are stable in place thanks to 4 M8 nuts every 50 cm.

Typical applications

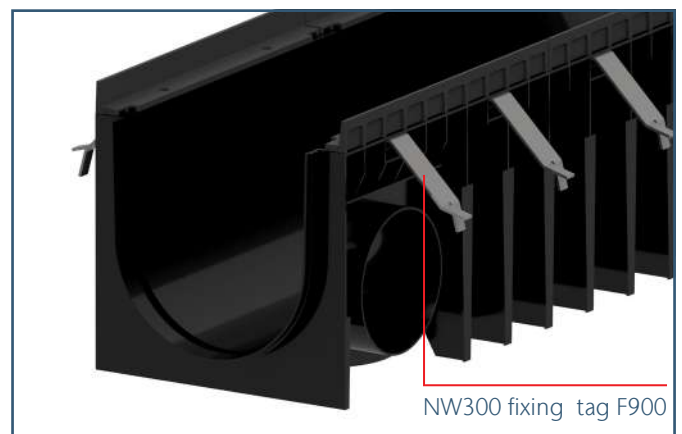
- Areas subject to loading/unloading of goods; container handling with transit of forklifts and truck
- Parking areas with high and constant traffic
- Roads and highways
- Viaducts
- Petrol stations
- Industrial areas
- Port and airport areas



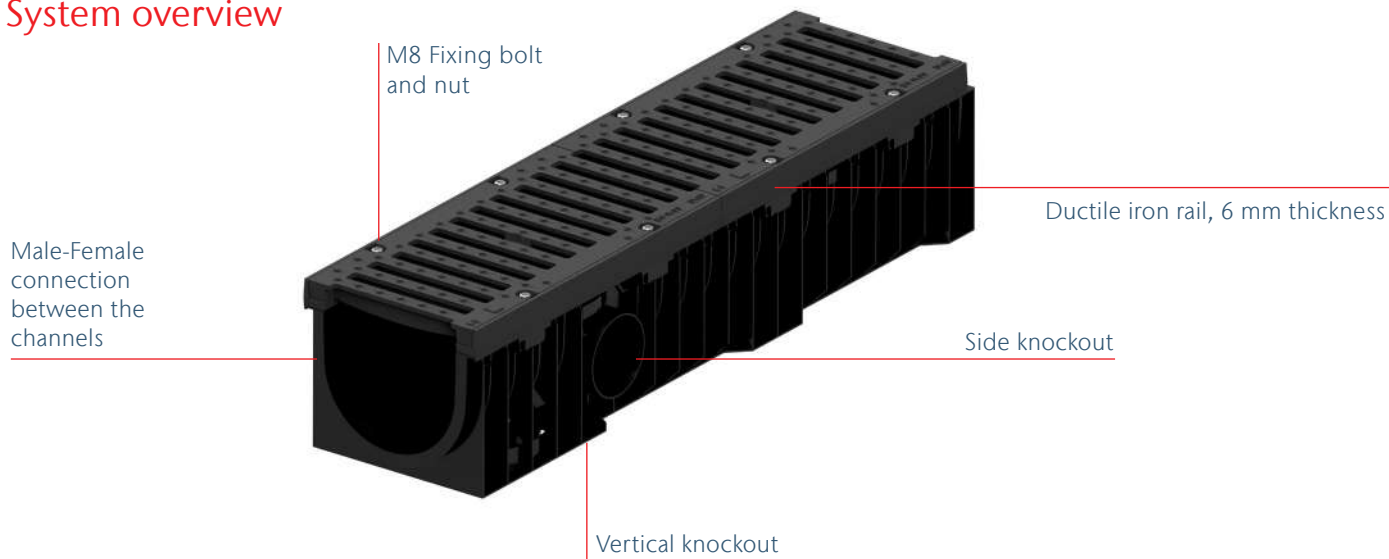
Main Features

- Plastic channel body certified for load class D400-F900 according to EN1433:2008
- Ductile iron rail
- 4 different nominal widths available: 100, 150, 200, 300 mm
- With vertical and lateral knockouts
- Sump unit with foul air trap*
- 4 bolts and nuts fixing system for each grating
- Special pieces for corners, "T" couplings and cross couplings are available on request

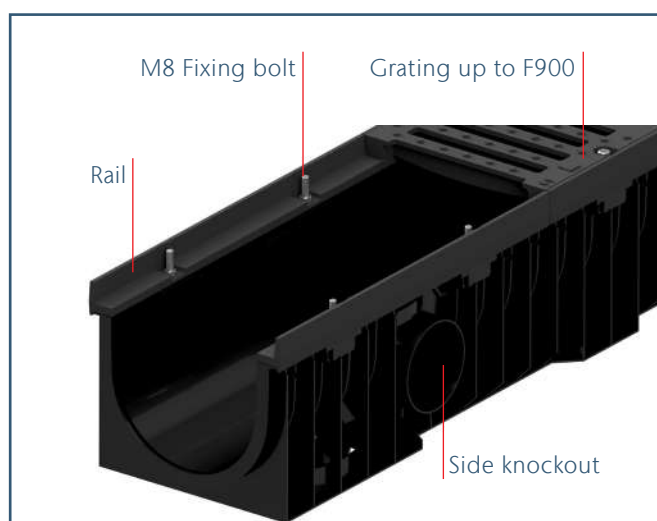
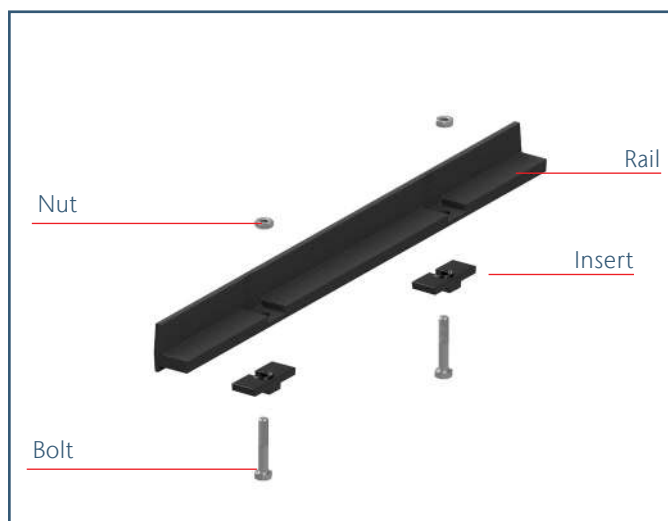
*Not available for Xtraline G 200 H=250 mm and Xtraline G 300 H=300 mm



System overview



Rail detail for channel internal width 100-150-200*



*For channel internal width 300, the insert is metallic.

Airsystem compost grating

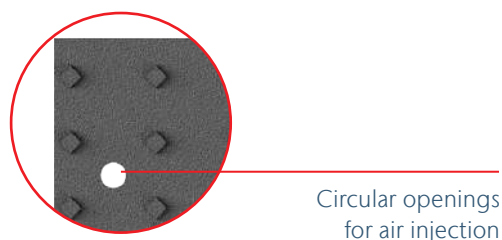
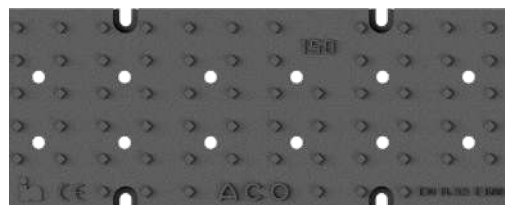
The AIRSYSTEM grating was developed together with the major construction companies specialized in large waste treatment plants. For these very special installations, it is necessary to convey big volumes of air into the rooms for the humid compounds treatment in order to ventilate and promote the aerobic composting processes.

The channel body, installed and integrated into the pavement, is the way to convey the air into the masses, while the gratings operates as real aerator.

The circular openings on the grating surface have the perfect geometry to inject air in the compost, at the same time, restrict the entry of percolating liquids inside the channel. The special “hook” connection, contains the pressure drop at the contact point between two following gratings.

In order to ensure the heavy work conditions in these special sites with all kinds of vehicles in transit on the drainage system, the Airsystem is tested for the load class E600. The gratings are fixed to the channels with 4 M8 bolts every 0,5 meter.

This system is available for 150mm clear width.



ACO Xtraline G 100

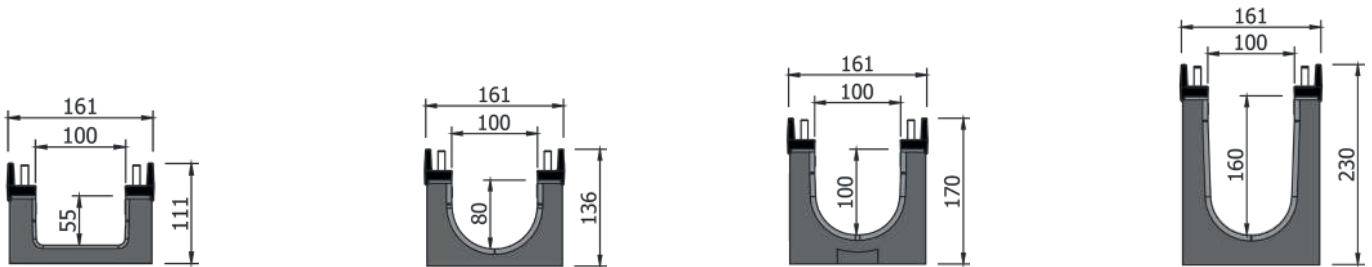
Product Information

- Plastic drainage channel, internal width: 100 mm
- Ductile iron rail
- Load classes: D 400 - F 900, according to EN 1433
- Sump unit with foul air trap
- Side and vertical knockouts
- Vertical outlet kit Ø100 and Ø110 mm for channels H 55 and H 80 mm; knockout on all other sizes
- M8 Bolts fixing system for gratings
- Special parts for corners, T-couplings and cross-couplings are available on request





ACO Xtraline G 100 channel with ductile iron rail

Length 1000 mm, total width 161 mm

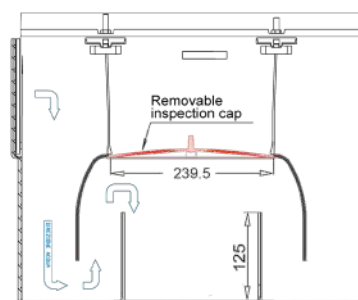
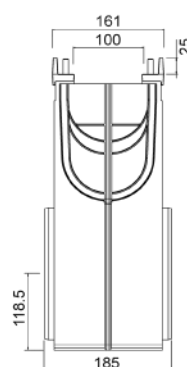
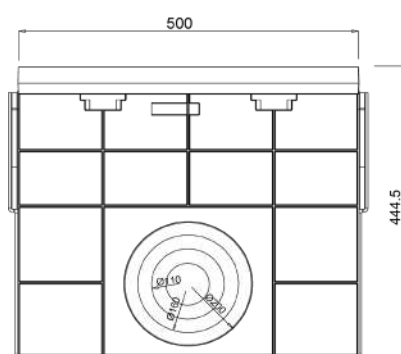


Total height	Internal height	Ø side outlet	Ø vertical outlet	Weight	Pieces/pallet	Ductile iron
[mm]	[mm]	[mm]	[mm]	[kg/pc]		Article number
Channel with vertical outlet kit Ø100/110						
111	55	2 x Ø40	1 x Ø100/110	7,80	84	840249
136	80	2 x Ø63	1 x Ø100/110	8,00	70	840250
Channel with vertical outlet Ø110						
170	100	2 x Ø63	1 x Ø110	8,30	56	840251
230	160	2 x Ø110	1 x Ø110	8,80	42	840252

ACO Xtraline G 100 channel accessories







Image	Description	For channel internal height [mm]	Material	Article number
	Closed end-cap	55	PE	840904
		80	PE	840905
		100	PE	840906
		160	PE	840907
	Ø40 outlet end-cap	55	PE	840900
	Ø50 outlet end-cap	80	PE	840946
	Ø75 outlet end-cap	100	PE	840947
		160	PE	840948
	Vertical outlet KIT Ø100	55/80	PE	840909
	Vertical outlet KIT Ø110	55/80	PE	840910
	Step connectors from 100 mm to 160 mm	-	Composit	840908

ACO Xtraline G 100 sump unit with ductile iron rail



Description	Material	Height [mm]	Width [mm]	Length [mm]	Ø Side Outlet [mm]	Weight [kg/pc]	Ductile Iron Article number
Sump unit with female-female connection	PE	444,5	161	500	2 x Ø110 2 x Ø160 2 x Ø200		840942

ACO Xtraline G 100 channel gratings

Image	Description	Fixing system	Width	Length	Slot/mesh	Weight	Article number
			[mm]	[mm]	[mm]	[kg/pc]	
D 400							
	Ductile iron square mesh	M8 nuts (not included)	148	498	22,5 x 22,5	4,80	840400
	Ductile iron heel safe mesh	M8 nuts (not included)	148	498	19 x 19	5,10	840496
	Ductile iron slot 20	M8 nuts (not included)	148	498	82 x 20	4,75	840401
E 600							
	Ductile iron slot 20	M8 nuts (not included)	148	498	82 x 20	5,10	840402
	Ductile iron solid top cover	M8 nuts (not included)	148	498	-	6,00	840403
F 900							
	Ductile iron slot 20	M8 nuts (not included)	148	498	82 x 20	6,30	840404

ACO Xtraline G 100 grating accessories

Description	Material	Valid for	Article number
M8 nuts	Galvanized steel	ACO Xtraline G 100 ductile iron gratings	840824 ⁽¹⁾

⁽¹⁾Valid for 1 meter of channel

ACO Xtraline G 150

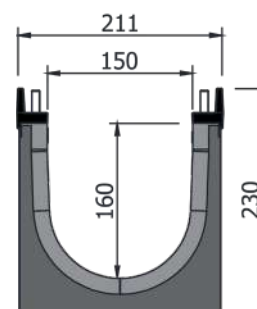
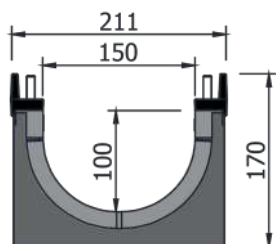
Product Information

- Plastic drainage channel, internal width: 150 mm
- Ductile iron rail
- Load classes: D 400 - F 900, according to EN 1433 norm
- Sump unit with foul air trap
- Side and vertical knockouts
- M8 bolt fixing system for gratings
- Special parts for corners, T-couplings and cross-couplings are available on request






ACO Xtraline G 150 channel with ductile iron rail

Length 1000 mm, total width 211 mm

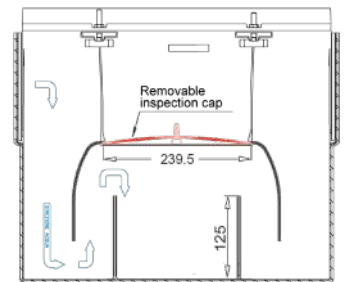
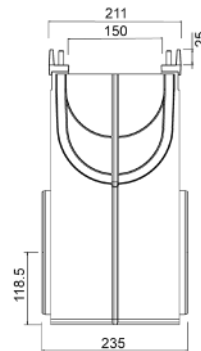
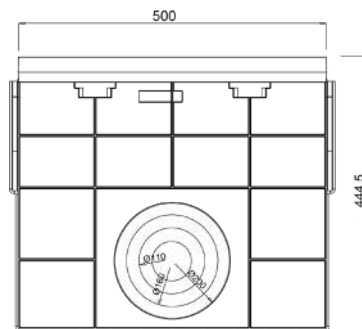


Total height	Internal height	Ø side outlet	Ø vertical outlet	Weight	Pieces/pallet	Ductile iron
[mm]	[mm]	[mm]	[mm]	[kg/pc]		Article number
Channel with vertical outlet Ø110/160						
170	100	2 x Ø63	1 x Ø110/160	8,70	40	840253
230	160	2 x Ø100	1 x Ø110/160	9,25	30	840254

ACO Xtraline G 150 channel accessories

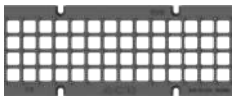
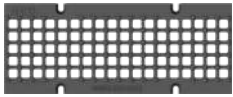



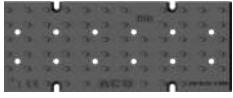

Image	Description	For channel internal height [mm]	Material	Article number
	Closed end-cap	100	PE	840912
		160	PE	840913
	Ø75 outlet end-cap	100	PE	840949
	Ø110 outlet end-cap	160	PE	840916
	Step connectors from 100 mm a 160 mm	-	Composit	840911

ACO Xtraline G 150 sump unit with ductile iron rail



Description	Material	Height [mm]	Width [mm]	Length [mm]	Ø Side outlet [mm]	Weight [kg/pc]	Ductile Iron Article number
Sump unit with female-female connection	PE	444,5	211	500	2xØ110 2xØ160 2xØ200	9,18	840943

ACO Xtraline G 150 channel gratings

Image	Description	Fixing system	Width [mm]	Lenght [mm]	Slot/mesh [mm]	Weight [kg/pc]	Article number
D 400							
	Ductile iron square mesh	M8 bolt (not included)	198	498	27 x 27	6,95	840503
	Ductile iron heel safe mesh	M8 bolt (not included)	198	498	19 x 19	7,50	840497
	Ductile iron slot 20	M8 nuts (not included)	198	498	132 x 20	7,10	840405
E 600							
	Ductile iron slot 20	M8 nuts (not included)	198	498	132 x 20	7,50	840406
	Ductile iron solid top cover	M8 nuts (not included)	198	498	-	10,60	840407
	Ductile iron airtsystem	M8 nuts (not included)	198	498	-	10,50	840408
F 900							
	Ductile iron slot 20	M8 nuts (not included)	198	498	132 x 20	8,50	840409

ACO Xtraline G 150 grating accessories

Description	Material	Valid for	Article number
M8 nuts	Galvanized steel	ACO Xtraline G 150 ductile iron gratings	840824 ⁽¹⁾

⁽¹⁾Valid for 1 meter of channel

ACO Xtraline G 200

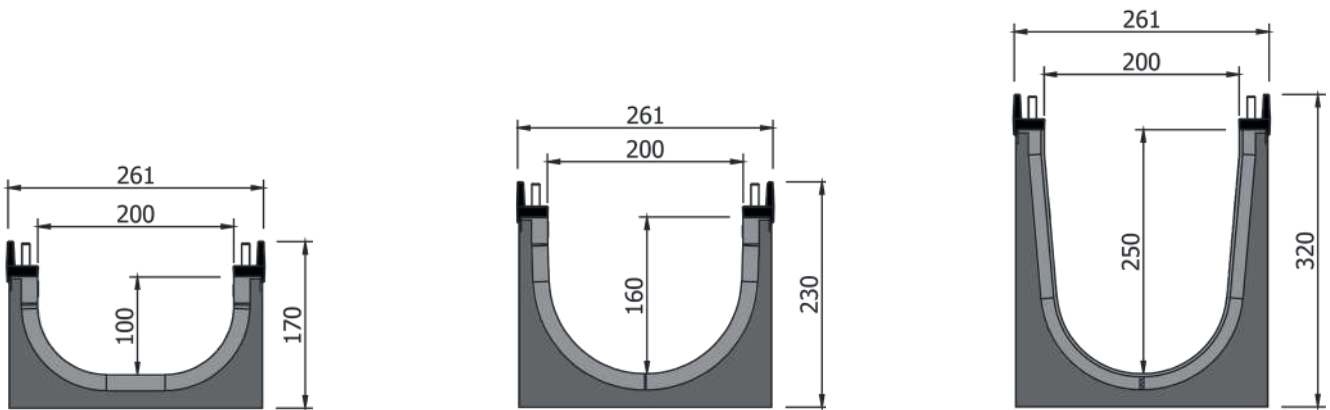
Product Information

- Plastic drainage channel, internal width: 200 mm
- Ductile iron rail
- Load classes: D 400 - F 900, according to EN 1433 norm
- Sump unit with foul air trap
- Side and vertical knockouts
- M8 bolt fixing system for gratings
- Special parts for corners, T-couplings and cross-couplings are available on request



ACO Xtraline G 200 channel with ductile iron rail





Length 1000 mm, total width 261 mm



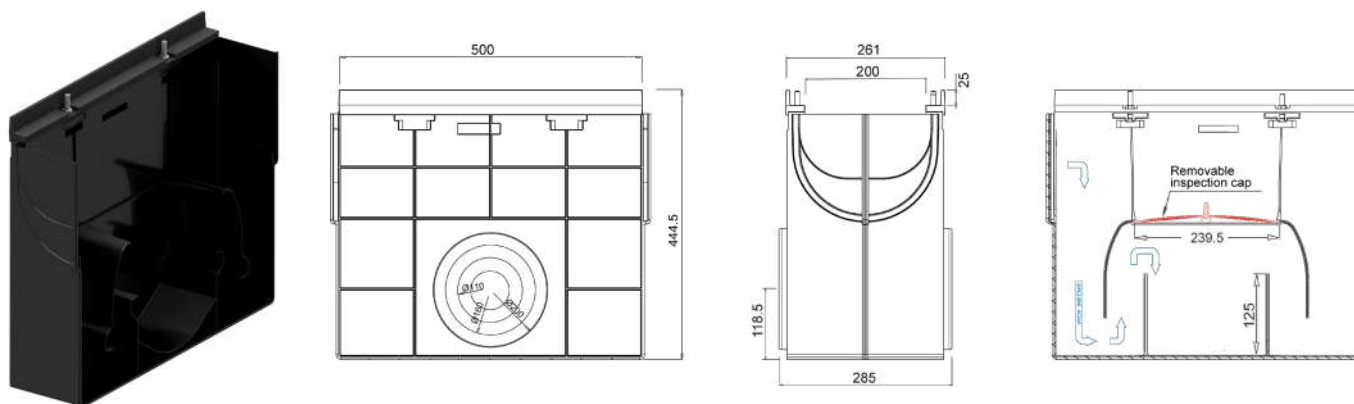
Total height	Internal height	Ø side outlet	Ø vertical outlet	Weight	Pieces/pallet	Ductile iron	
[mm]	[mm]	[mm]	[mm]	[kg/pz]		Article number	
170	100	2 x Ø63	1 x Ø200/160	9,05	32	840255	
230	160	2 x Ø110	1 x Ø200/160	9,65	24	840256	
320	250	2 x Ø160/200	1 x Ø200/160	11,20	16	840257	

Channel with vertical outlet Ø200/160

ACO Xtraline G 200 channel accessories

Image	Description	For channel internal height [mm]	Material	Article number
	Closed end-cap	100	PE	840919
		160	PE	840920
	Ø75 outlet end-cap	100	PE	840950
	Ø110 outlet end-cap	160	PE	840923
	Closed end-cap with Ø160 knockout	250	PE	840924
	Step connectors from 100 mm to 160 mm	-	Composit	840917
	Step connectors from 160 mm to 250 mm	-	Composit	840918

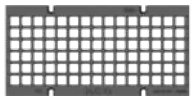
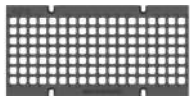




ACO Xtraline G 200 sump unit with ductile iron rail



Description	Material	Height [mm]	Width [mm]	Length [mm]	Ø Side Outlet [mm]	Weight [kg/pc]	Ductile iron Article number
Sump unit with female-female connection	PE	444,5	261	500	2xØ110 2xØ160 2xØ200	9,40	840944 ⁽¹⁾

⁽¹⁾It is not designed for connection to H250 channels

ACO Xtraline G 200 channel gratings

Image	Description	Fixing system	Width [mm]	Length [mm]	Slot/Mesh [mm]	Weight [kg/pc]	Article number
D 400							
	Ductile iron square mesh	M8 bolt (not included)	248	498	24 x 25	8,50	840504
	Ductile iron heel safe mesh	M8 bolt (not included)	248	498	19 x 19	9,50	840498
	Ductile iron slot 20	M8 nuts (not included)	248	498	182 x 20	8,20	840410
E 600							
	Ductile iron slot 20	M8 nuts (not included)	248	498	182 x 20	9,70	840412
	Ductile iron solid top cover	M8 nuts (not included)	248	498	-	12,00	840413
F 900							
	Ductile iron slot 20	M8 nuts (not included)	248	498	182 x 20	10,50	840414

ACO Xtraline G 200 grating accessories

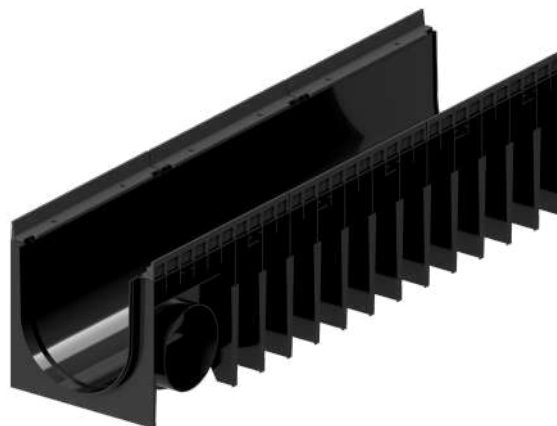
Description	Material	Valid for	Article number
M8 Nuts	Galvanized steel	ACO Xtraline G 200 ductile iron gratings	840824 ⁽¹⁾

⁽¹⁾Valid for 1 meter of channel

ACO Xtraline G 300

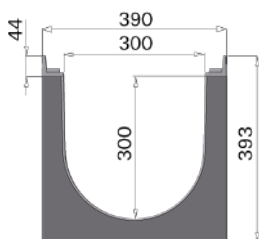
Product information

- Plastic drainage channel, internal width: 300 mm
- Ductile iron rail
- Load classes: D 400 - F 900, according to EN 1433 norm
- Side and vertical knockouts
- M10 fixing system for gratings
- Ideal for drainage of large surface



ACO Xtraline G 300 channel with ductile iron rail



Length 1500 mm, total width 390 mm



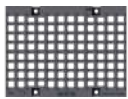
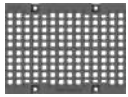
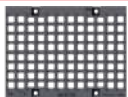


Total height	Internal height	Ø side outlet	Ø vertical outlet	Type of rail	Weight	Pieces/pallet	Article number
[mm]	[mm]	[mm]	[mm]		[kg/pc]		
393	300	2 x Ø200	1 x Ø160/200	Ductile iron	20,90	10*	840211

(*) 6 pieces for F900 type.

Accessories for ACO Xtraline G 300 Channel



Image	Description	For channel internal height	Material	Article number
		[mm]		
	Closed end-cap	300	Galvanized steel	840926
	Ø200 outlet end-cap	300	Galvanized steel	840925

ACO Xtraline G 300 channel gratings

Image	Description	Fixing system	Width [mm]	Length [mm]	Slot/mesh [mm]	Weight [kg/pc]	Article number
D 400							
	Ductile iron square mesh	M10 Nuts (not included)	376	498	25 x 25	18,70	840415
	Ductile iron heel safe mesh	M10 Nuts (not included)	376	498	19 x 19	21,00	840499
E 600							
	Ductile iron square mesh	M10 Nuts (not included)	376	498	25 x 25	22,00	840416
	Ductile iron solid top cover	M10 Nuts (not included)	376	498	-	26,00	840417
F900							
	Ductile iron slot 24	M10 Nuts and fixing tag F900 (not included)	376	498	130 x 24	27,50	840488 ⁽¹⁾

⁽¹⁾ Fixing tag F900 is needed to reach F900 load class and it is suggested in others heavy installations

ACO Xtraline G 300 gratings accessories

Image	Description	Material	Valid for	Article number
	Blind nut M10	Galvanized steel	ACO Xtraline G 300 ductile iron gratings	840813 ⁽²⁾
		Stainless steel	ACO Xtraline G 300 ductile iron gratings	840814 ⁽²⁾
	Fixing tag F900 (12 pcs)	Galvanized steel	ACO Xtraline G 300 F900 ductile iron gratings (assembled before shipment)	840825

⁽²⁾ Valid for 1,5 meter of channel



2 ACO Xtraline B
Drainage channel

COLLECT:
Collect and convey



ACO Xtraline B – Plastic drainage channels

ACO Xtraline B 100	Channel body	P. 22
	Channel accessories	P. 23
	Sump unit	P. 23
	Gratings	P. 24
ACO Xtraline B 150	Channel body	P. 25
	Channel accessories	P. 26
	Sump unit	P. 26
	Gratings	P. 27
ACO Xtraline B 200	Channel body	P. 28
	Channel accessories	P. 29
	Sump unit	P. 29
	Gratings	P. 30



Declaration of performance at:
www.aco.it/download/dop-e-certificati/

ACO Xtraline B: Safety of the steel rail and bolted locking system

ACO Xtraline B is the ACO range of products designed for industrial and infrastructural areas, where the activities (loading and unloading of goods, transit of heavy vehicles, etc.) require the highest performance features.

The channel body, completely made of HD-PE, is equipped with a galvanized steel rail, suitable and certified up to the F 900 load class.

The rail, perfectly anchored to the channel body, has a thickness of 4 mm in the area subject to the traffic effects and a thickness of 2 mm to support for the grating area. Four M8 Bolts for every 50 cm fix the gratings to the channel body.

The fixing system also gives the name to this product range where B, stays for bolt, in the number of 4 per grating.

Typical applications

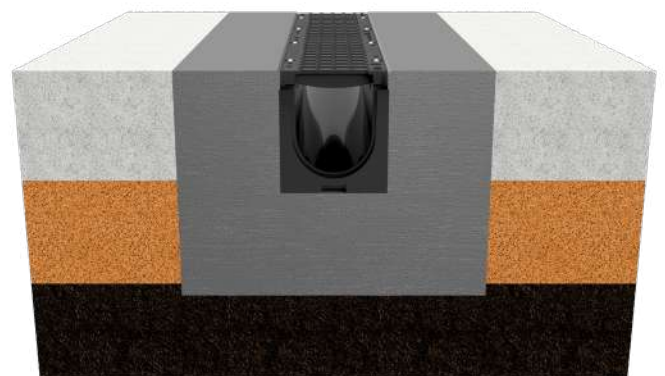
- Areas subject to loading / unloading of goods; container handling with transit of forklifts and trucks.
- Parking areas with high and constant traffic
- Roads and highways
- Viaducts
- Petrol stations
- Industrial areas
- Port and airport areas.



Main Features

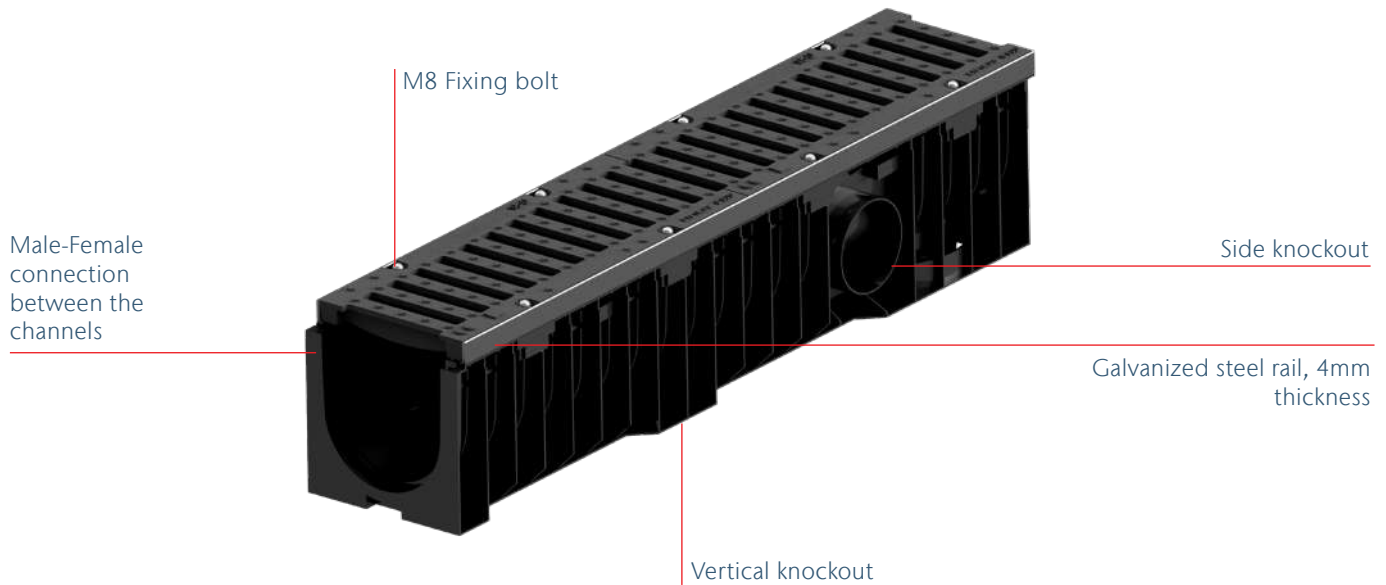
- Plastic channel body certified for load class C 250 - F 900 according to EN 1433: 2008
- Galvanized steel rail
- 3 different nominal widths available: 100, 150, 200 mm
- With vertical and lateral knockouts
- Vertical outlet kit Ø100 and Ø110 mm for channels H55 and H80 mm
- Sump unit with foul air trap*
- 4 bolts fixing system for each grating
- Special pieces for corners, "T" couplings and cross couplings are available

*Not available for Xtraline B 200 H=250 mm and Xtraline B 300 H=300 mm



Example of installation

System overview



Drainage asphalt grating

ACO Xtraline G drainage asphalt grating

Cast iron grating, load class D400 designed for road and motorway installations where the use of drainage asphalt is planned.

With its particular design with a raised edge of 5cm, the grating exceeds the limit of standard gratings whereby water is only captured from the upper part of the same.

By placing the grating at the same level as the ground level, both the water that flows on the surface and that coming from the deep layers of the drainage pavements are collected.

The result is a correct and safe disposal of flows for modern and increasingly safer infrastructures.



ACO Xtraline B 100

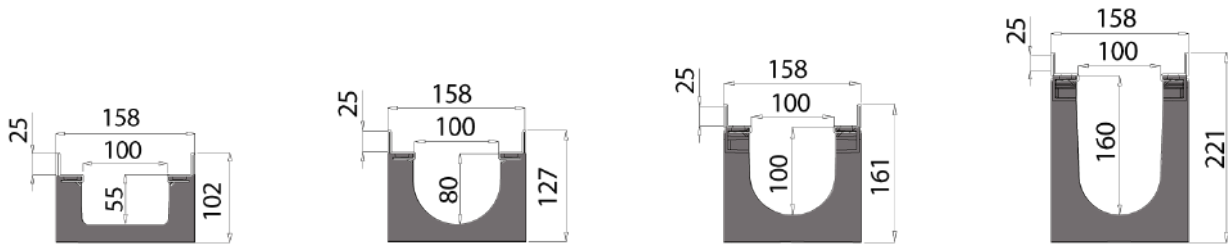
Product Information

- Plastic drainage channel, internal width: 100 mm
- Galvanized steel rail
- Load classes: C 250 - F 900, according to EN 1433
- Sump unit with foul air trap
- Side and vertical knockouts
- Vertical outlet kit $\varnothing 100$ and $\varnothing 110$ mm for channels H 55 and H 80 mm; knockout on all other sizes
- M8 bolts fixing system for gratings
- Special parts for corners, T-couplings and cross-couplings are available on request






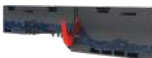
ACO Xtraline B 100 channel with galvanized Steel rail

Length 1000 mm, total width 158 mm

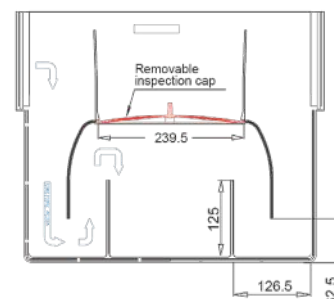
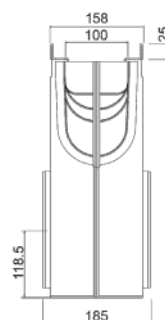
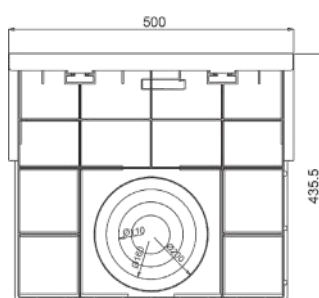


Total height	Internal height	Ø side outlet	Ø vertical outlet	Weight	Pieces/pallet	Galvanized steel
[mm]	[mm]	[mm]	[mm]	[kg/pc]		Article number
Channel with vertical outlet kit $\varnothing 100/110$						
102	55	2 x $\varnothing 40$	1 x $\varnothing 100/110$	3,90	84	840200
127	80	2 x $\varnothing 63$	1 x $\varnothing 100/110$	4,10	70	840201
Channel with vertical outlet knockout $\varnothing 110$						
161	100	2 x $\varnothing 63$	1 x $\varnothing 110$	4,40	56	840202
221	160	2 x $\varnothing 110$	1 x $\varnothing 110$	4,90	42	840203

ACO Xtraline B 100 channel accessories







Image	Description	For channel internal height [mm]	Material	Article number
	Closed end-cap	55	PE	840904
		80	PE	840905
		100	PE	840906
		160	PE	840907
	Ø40 outlet end-cap	55	PE	840900
	Ø50 outlet end-cap	80	PE	840946
	Ø75 outlet end-cap	100	PE	840947
		160	PE	840948
	Vertical outlet KIT Ø100	55/80	PE	840909
	Vertical outlet KIT Ø110	55/80	PE	840910
	Step connectors from 100 mm to 160 mm	-	Composit	840908

ACO Xtraline B 100 sump unit with galvanized steel rail



Description	Material	Height [mm]	Width [mm]	Length [mm]	Ø side outlet [mm]	Weight [kg/pc]	Galvanized steel Article number
Sump unit with female-female connection	PE	435,5	158	500	2xØ110 2xØ160 2xØ200	3,75	840927

ACO Xtraline B 100 channel gratings

Image	Description	Fixing system	Width [mm]	Length [mm]	Slot/mesh [mm]	Weight [kg/pc]	Article number
D 400							
	Ductile iron square mesh	M8 nuts (not included)	148	498	22,5 x 22,5	4,80	840400
	Ductile iron heel safe mesh	M8 nuts (not included)	148	498	19 x 19	5,10	840496
	Ductile iron slot 20	M8 nuts (not included)	148	498	82 x 20	4,75	840401
E 600							
	Ductile iron slot 20	M8 nuts (not included)	148	498	82 x 20	5,10	840402
	Ductile iron solid top cover	M8 nuts (not included)	148	498	-	6,00	840403
F 900							
	Ductile iron slot 20	M8 nuts (not included)	148	498	82 x 20	6,30	840404

ACO Xtraline B 100 grating accessories

Description	Material	Valid for	Article Number
M8 x 40 Black flanged hex head bolt	Galvanized steel	ACO Xtraline B 100 ductile iron grating	840809 ⁽¹⁾

⁽¹⁾Valid for 1 meter of channel

ACO Xtraline B 150

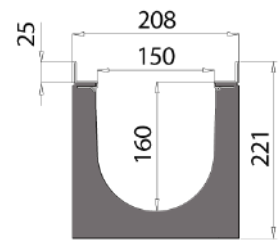
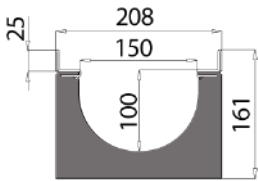
Product Information

- Plastic drainage channel, internal width: 150 mm
- Galvanized steel rail
- Load classes: C 250 - F 900, according to EN 1433 norm
- Sump unit with foul air trap
- Side and vertical knockouts
- M8 bolt fixing system for gratings
- Special parts for corners, T-couplings and cross-couplings are available on request






ACO Xtraline B 150 channel with galvanized steel rail

Length 1000 mm, total width 208 mm

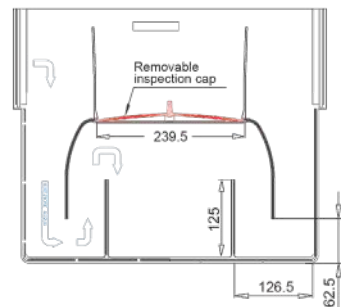
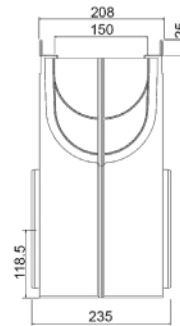
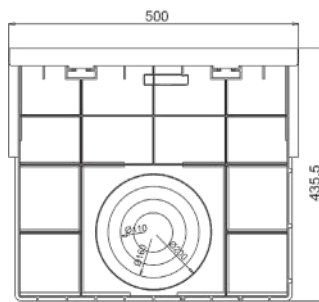


Total height	Internal height	Ø side outlet	Ø vertical outlet	Weight	Pieces/pallet	Galvanized steel
[mm]	[mm]	[mm]	[mm]	[kg/pc]		Article number
Channel with vertical outlet Ø110						
161	100	2 x Ø63	1 x Ø110/160	4,80	40	840206
221	160	2 x Ø100	1 x Ø110/160	5,35	30	840207

ACO Xtraline B 150 channel accessories

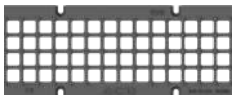
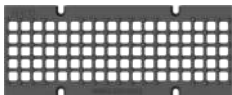


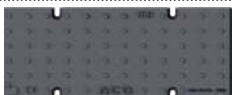


Image	Description	For channel internal height [mm]	Material	Article number
	Closed end-cap	100	PE	840912
		160	PE	840913
	Ø75 outlet end-cap	100	PE	840949
	Ø110 outlet end-cap	160	PE	840916
	Step connectors from 100 mm a 160 mm	-	Composit	840911

ACO Xtraline B 150 sump unit with galvanized steel rail



Description	Material	Height [mm]	Width [mm]	Length [mm]	Ø side outlet [mm]	Weight [kg/pc]	Galvanized steel Article number
Sump unit with female-female connection	PE	435,5	208	500	2xØ110 2xØ160 2xØ200	3,70	840928

ACO Xtraline B 150 channel gratings

Image	Description	Fixing system	Width [mm]	Lenght [mm]	Slot/mesh [mm]	Weight [kg/pc]	Article number
D 400							
	Ductile iron square mesh	M8 bolt (not included)	198	498	27 x 27	6,95	840503
	Ductile iron heel safe mesh	M8 bolt (not included)	198	498	19 x 19	7,50	840497
	Ductile iron slot 20	M8 nuts (not included)	198	498	132 x 20	7,10	840405
E 600							
	Ductile iron slot 20	M8 nuts (not included)	198	498	132 x 20	7,50	840406
	Ductile iron solid top cover	M8 nuts (not included)	198	498	-	10,60	840407
	Ductile iron airsystem	M8 nuts (not included)	198	498	-	10,50	840408
F 900							
	Ductile iron slot 20	M8 nuts (not included)	198	498	132 x 20	8,50	840409

ACO Xtraline B 150 grating accessories

Description	Material	Valid for	Article number
M8 x 40 black flanged hex head bolt	Galvanized steel	ACO Xtraline B 150 ductile iron grating	840809 ⁽¹⁾

⁽¹⁾Valid for 1 meter of channel

ACO Xtraline B 200

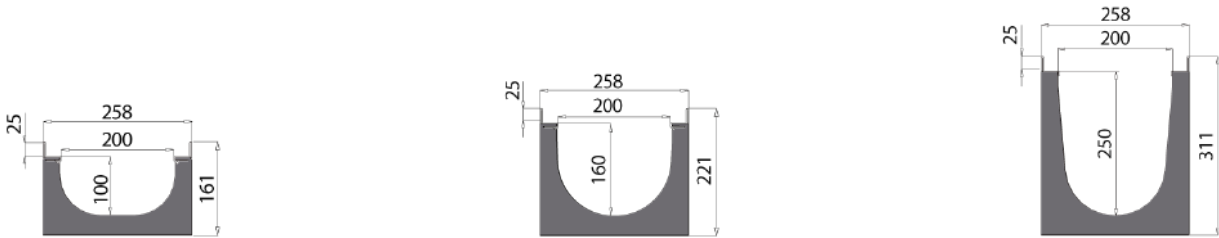
Product Information

- Plastic drainage channel, internal width: 200 mm
- Galvanized steel rail
- Load classes: C 250 - F 900, according to EN 1433 norm
- Sump unit with foul air trap
- Side and vertical knockouts
- M8 bolt fixing system for gratings
- Special parts for corners, T-couplings and cross-couplings are available on request







ACO Xtraline B 200 channel with galvanized steel rail

Length 1000 mm, total width 258 mm

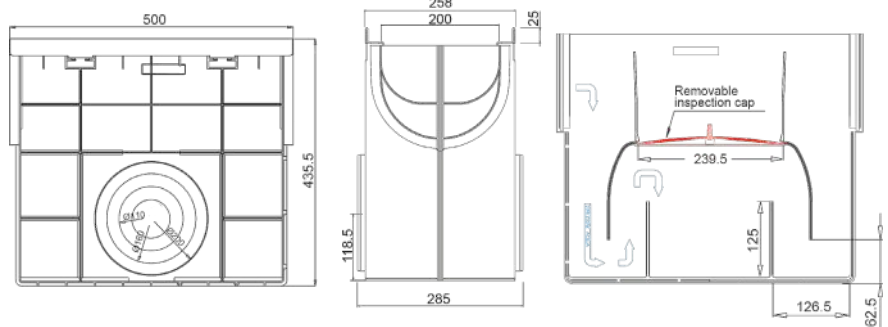


Total height	Internal height	Ø side outlet	Ø vertical outlet	Weight	Pieces/pallet	Galvanized steel
[mm]	[mm]	[mm]	[mm]	[kg/pz]		Article number
Channel with vertical outlet Ø200/160						
161	100	2 x Ø63	1 x Ø200/160	5,15	32	840208
221	160	2 x Ø110	1 x Ø200/160	5,75	24	840209
311	250	2 x Ø160/200	1 x Ø200/160	7,50	16	840210

ACO Xtraline B 200 channel accessories

Image	Description	For channel internal height [mm]	Material	Article number
	Closed end-cap	100	PE	840919
		160	PE	840920
	Ø75 outlet end-cap	100	PE	840950
	Ø110 outlet end-cap	160	PE	840923
	Closed end-cap with Ø160 knockout	250	PE	840924
	Step connectors from 100 mm to 160 mm	-	Composit	840917
	Step connectors from 160 mm to 250 mm	-	Composit	840918

ACO Xtraline B 200 sump unit with galvanized steel rail



Description	Material	Height [mm]	Width [mm]	Length [mm]	Ø side outlet [mm]	Weight [kg/pc]	Galvanized steel Article number
Sump unit with female-female connection	PE	435,5	258	500	2xØ110 2xØ160 2xØ200	4,20	840929 ⁽¹⁾

⁽¹⁾It is not designed for connection to H250 channels

ACO Xtraline B 200 channel gratings

Image	Description	Fixing system	Width [mm]	Length [mm]	Slot/mesh [mm]	Weight [kg/pc]	Article number
D 400							
	Ductile iron square mesh	M8 bolt (not included)	248	498	24 x 25	8,50	840504
	Ductile iron heel safe mesh	M8 bolt (not included)	248	498	19 x 19	9,50	840498
	Ductile iron slot 20	M8 nuts (not included)	248	498	182 x 20	8,20	840410
E 600							
	Ductile iron slot 20	M8 nuts (not included)	248	498	182 x 20	9,70	840412
	Ductile iron solid top cover	M8 nuts (not included)	248	498	-	12,00	840413
F 900							
	Ductile iron slot 20	M8 nuts (not included)	248	498	182 x 20	10,50	840414

ACO Xtraline B 200 grating accessories

Description	Material	Valid for	Article number
M8 x 40 Black flanged hex head bolt	Galvanized steel	ACO Xtraline B 200 ductile iron grating	840809 ⁽¹⁾

⁽¹⁾Valid for 1 meter of channel



3 ACO Xtraline S
Drainage channel

COLLECT:
Collect and convey



ACO Xtraline S – Plastic drainage channels

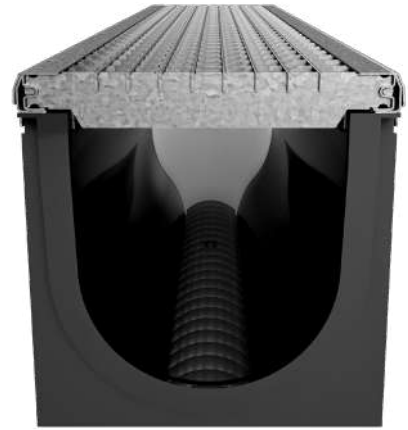
ACO Xtraline S 100	Channel	P. 36
	Accessories	P. 37
	Sump unit	P. 37
	Gratings and accessories	P. 38
ACO Xtraline S 150	Channel	P. 39
	Accessories	P. 40
	Sump unit	P. 40
	Gratings and accessories	P. 41
ACO Xtraline S 200	Channel	P. 42
	Accessories	P. 43
	Sump unit	P. 43
	Gratings and accessories	P. 44



Declaration of performance:
www.aco.it/download/dop

ACO Xtraline S: steel rail safety

The **ACO Xtraline S** drainage system represents the perfect answer for the civil, industrial and infrastructural application needs. The versatility of these channels is a consequence of its steel rail (galvanized or stainless steel), necessary to improve the load distribution coming from the pavement surface or from underground forces. At the same time, it is the perfect protection for the complete system from all the forces coming from the surrounding areas. The S of the Steel rail gives the name to this multipurpose channel range. The 2,5mm rail thickness in the traffic exposure area and 1,2 mm thickness in the grating support area, grants a C250 load class certification. The fixing system consists of 2 bars and bolts per each single meter.



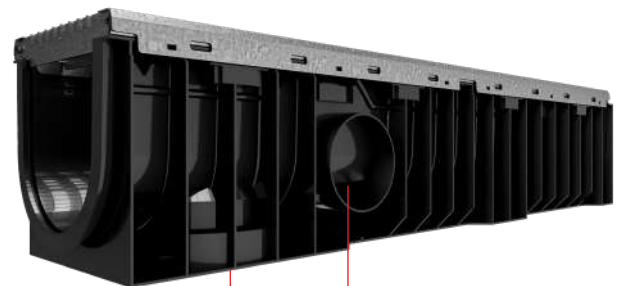
The steel rail is 20 mm high and 2.5 mm thick in the area exposed to vehicle transit. It holds the gratings and helps in an easy installation of the channel system.

Typical applications

- Private parking
- Sidewalks
- Access to ramps in underground floors
- Roadside drainage systems
- Parking areas
- Other applications for load class C250

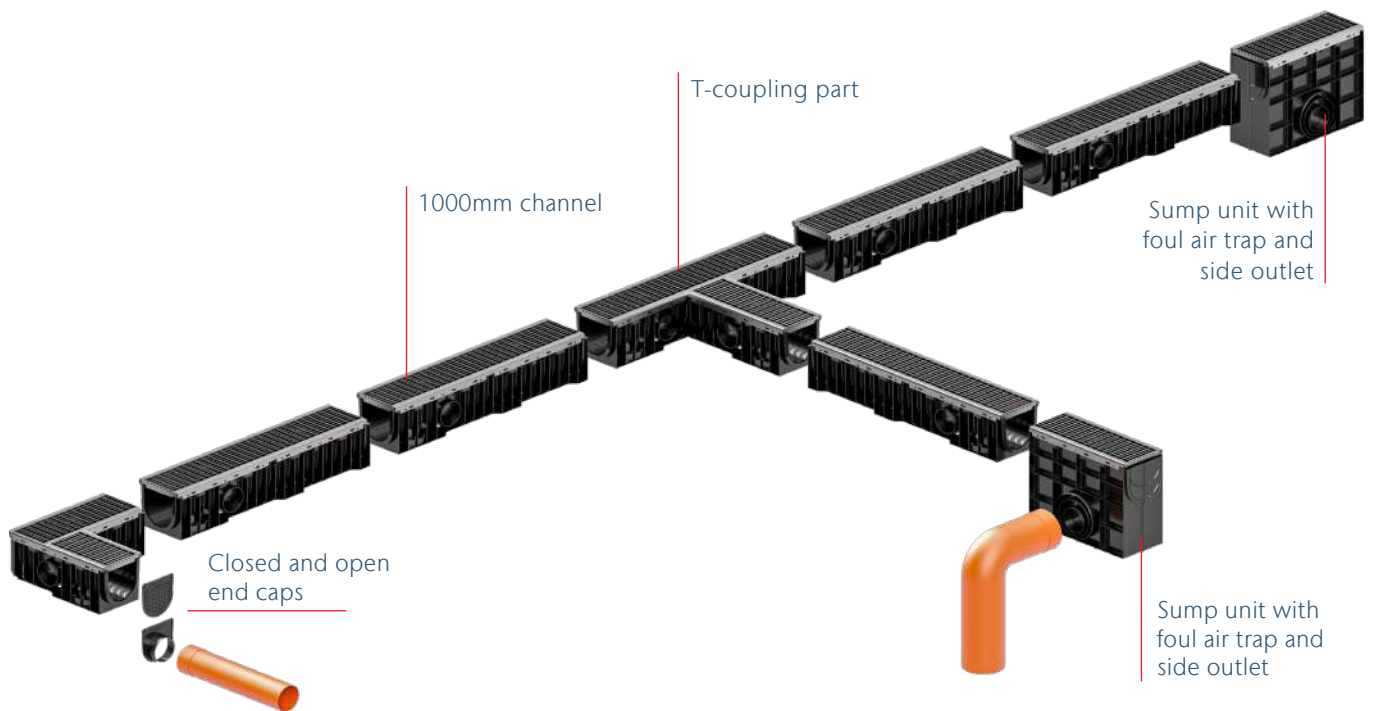
Main features

- The channel body is completely made of plastic, certified for load class A15, B125 and C250 according to EN 1433: 2008
- Galvanized steel and stainless steel rail are standard for this product
- Available in three different nominal widths: 100, 150, 200 mm
- With vertical and lateral knockouts
- Vertical outlet kit Ø100 and Ø110 mm for channels H55 and H80 mm
- Sump unit with foul air trap
- Specific fixing systems on each grating.
- Special pieces for corners, “T” couplings and cross couplings are available



Vertical and lateral knockouts

System overview



ACO Xtraline S is available:

- With three different widths: from 100, 150 and 200 mm
- With two low height versions 55 mm and 80 mm for the channel internal width 100 mm.



ACO Xtraline S 100

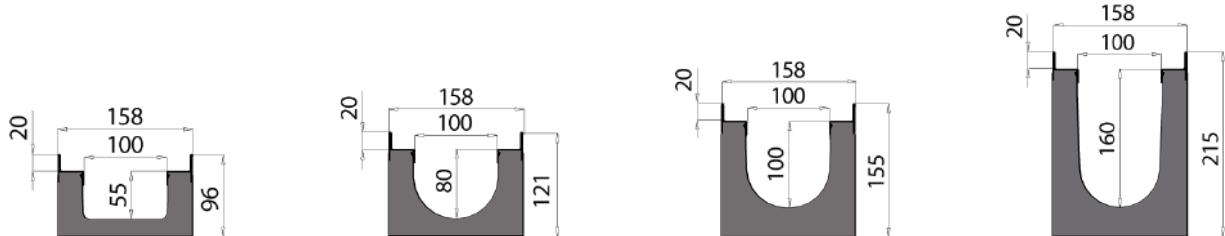
Product information

- Plastic body channel, internal width: 100 mm
- Galvanized steel and stainless steel rail
- For load classes: B 125 and C 250, according to EN 1433 norm
- Equipped with sump unit and foul air trap
- Side and vertical knockouts
- Vertical outlet kit Ø100 and Ø110 mm for channels H 55 and H 80 mm; knockout on all other sizes
- Bolt and bar fixing system for the gratings
- Special parts for corners, T-couplings and cross-couplings available






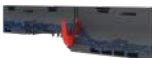
ACO Xtraline S 100 channel with galvanized and stainless steel rail

Length 1000 mm, total width 158 mm

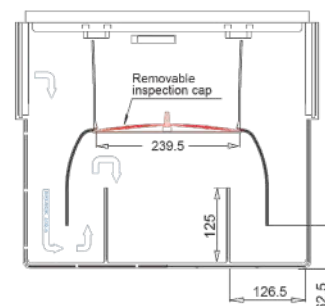
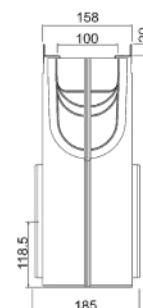
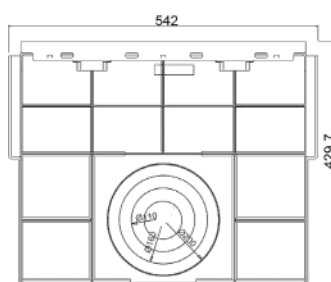


Total height [mm]	Internal height [mm]	Ø side outlet [mm]	Ø vertical outlet [mm]	Weight [kg/pc]	Pieces/pallet	Stainless steel	Galvanized steel
						Article number	Article number
Channel with vertical outlet kit Ø100/110							
96	55	2 x Ø40	1 x Ø100/110	3,10	84	840226	840222
121	80	2 x Ø63	1 x Ø100/110	3,30	70	840227	840223
Channel with vertical outlet Ø110							
155	100	2 x Ø63	1 x Ø110	3,60	56	840228	840224
215	160	2 x Ø110	1 x Ø110	4,10	42	840229	840225

ACO Xtraline S 100 channel accessories

Image	Description	For channel internal height [mm]	Material	Article number
	Closed end-cap	55	PE	840904
		80	PE	840905
		100	PE	840906
		160	PE	840907
	Ø40 outlet end-cap	55	PE	840900
	Ø50 outlet end-cap	80	PE	840946
	Ø75 outlet end-cap	100	PE	840947
		160	PE	840948
	KIT Ø100 vertical outlet	55/80	PE	840909
	KIT Ø110 vertical outlet	55/80	PE	840910
	Step connectors from 100 mm to 160 mm	-	Composit	840908

ACO Xtraline S 100 sump unit with galvanized/stainless steel rail



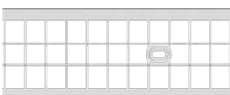
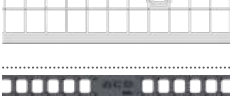




Description	Material	Height [mm]	Width [mm]	Length [mm]	Ø Side Outlet [mm]	Weight [kg/pz]	Stainless Steel	Galvanized Steel
							Article number	Article number
Sump unit with female-female connection	PE	429,7	158	500	2xØ110 2xØ160 2xØ200	3,35	840934	840933


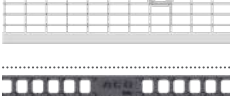
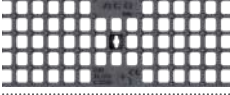



ACO Xtraline S 100 channel gratings

Image	Description	Fixing system	Width	Length	Slot/mesh	Weight	Article number
			[mm]	[mm]	[mm]	[kg/pc]	



B 125

	Galvanized steel heel safe mesh	Bolt and bar (not included)	148	998	33 x 15	3,60	840429
	Stainless steel heel safe mesh	Bolt and bar (not included)	148	998	33 x 15	3,60	840436
	Galvanized steel square mesh	Bolt and bar (not included)	148	998	32,2 x 32,2	2,90	840430
	Stainless steel square mesh	Bolt and bar (not included)	148	998	32,2 x 32,2	2,90	840437
	Ductile iron mesh	Bolt and bar (not included)	148	498	21,5 x 17,5	3,40	840431
	Polyamide 16 mm slot	Bolt and bar (not included)	148	498	82 x 20	0,80	840510

C 250

	Galvanized steel heel safe mesh	Bolt and bar (not included)	148	998	33 x 15	5,10	840432
	Stainless steel heel safe mesh	Bolt and bar (not included)	148	998	33 x 15	5,10	840438
	Ductile iron mesh	Bolt and bar (not included)	148	498	21,5 x 17,5	3,80	840433
	Ductile iron 7 mm slot	Bolt and bar (not included)	148	498	57 x 7	4,10	840439
	Ductile iron 20 mm slot	Bolt and bar (not included)	148	498	82 x 20	3,60	840434
	Polyamide 16 mm slot	Bolt and bar (not included)	148	498	82 x 20	1,30	840511

ACO Xtraline S 100 grating accessories

Image	Description	Material	Valid for	Article number
	Bolt and bar kit + M8x40 TBL combi screw	Galvanized steel	Xtraline S 100 galvanized steel gratings	840821 ⁽¹⁾
		Stainless steel	Xtraline S 100 stainless steel gratings	840822 ⁽¹⁾
	Bolt and bar kit + M8x40 black hex head screw	Galvanized steel	Xtraline S 100 ductile iron gratings	840823 ⁽¹⁾

⁽¹⁾Valid for 1 meter of channel

ACO Xtraline S 150

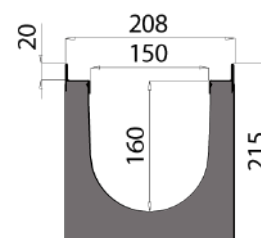
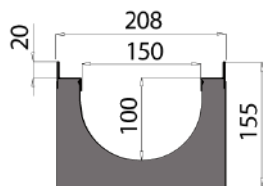
Product information

- Plastic drainage channel, internal width: 150 mm
- Galvanized Steel and stainless steel rail
- For load classes: B 125 – C 250, according to EN 1433 norm
- Equipped with sump unit and foul air trap
- Side and vertical knockouts
- Bolt and bar fixing system for gratings
- Availability of special parts for corners, T-couplings and cross-couplings



ACO Xtraline S 150 channel with galvanized/stainless steel rail




Length 1000 mm, total width 208 mm



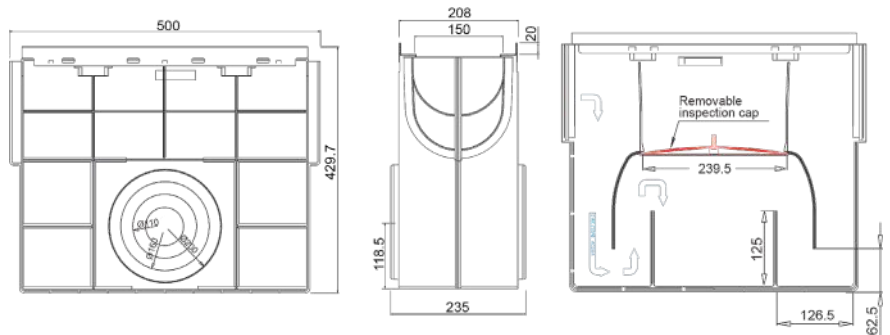
Total height [mm]	Internal height [mm]	Ø side outlet [mm]	Ø vertical outlet [mm]	Weight [kg/pc]	Pieces/pallet	Stainless steel	Galvanized steel
						Article number	Article number
155	100	2 x Ø63	1 x Ø110/160	4,00	40	840232	840230
215	160	2 x Ø110	1 x Ø110/160	4,55	30	840233	840231

Channel with vertical outlet Ø110/160

ACO Xtraline S 150 channel accessories





Image	Description	For channel internal height [mm]	Material	Article number
	Closed end-cap	100	PE	840912
		160	PE	840913
	Ø75 outlet end-cap	100	PE	840949
	Ø110 outlet end-cap	160	PE	840916
	Step connectors from 100 mm to 160 mm	-	Composit	840911

ACO Xtraline S 150 sump unit with galvanized/stainless steel rail




Description	Material	Height [mm]	Width [mm]	Length [mm]	Ø Side Outlet [mm]	Weight [kg/pc]	Stainless Steel	Galvanized Steel
							Article number	Article number
Sump unit with female-female connection	PE	429,7	208	500	2xØ110 2xØ160 2xØ200	3,70	840936	840935

ACO Xtraline S 150 channel gratings

Image	Description	Fixing System	Width [mm]	Length [mm]	Slot/Mesh [mm]	Weight [kg/pc]	Article number
B 125							
	Galvanized steel heel safe mesh	Bolt and bar (not included)	198	998	33 x 15	5,30	840442
	Stainless steel heel safe mesh	Bolt and bar (not included)	198	998	33 x 15	5,00	840448
	Galvanized steel square mesh	Bolt and bar (not included)	198	998	32,2 x 32,2	4,10	840443
	Stainless steel square mesh	Bolt and bar (not included)	198	998	32,2 x 32,2	4,10	840449
	Ductile iron mesh	Bolt and bar (not included)	198	498	29 x 24,5	4,90	840444
	Polyamide 16mm slot	Bolt and bar (not included)	198	498	132 x 16	1,70	840424
	Ductile iron 7mm slot	Bolt and bar (not included)	198	498	81 x 7	5,97	840447
C 250							
	Galvanized steel heel safe mesh	Bolt and bar (not included)	198	998	33 x 15	7,50	840445
	Stainless steel heel safe mesh	Bolt and bar (not included)	198	998	33 x 15	7,50	840450
	Ductile iron 20mm slot	Bolt and bar (not included)	198	498	132 x 20	5,30	840446
	Polyamide 16mm slot	Bolt and bar (not included)	198	498	132 x 16	2,35	840451
	Ductile iron 8mm slot	Bolt and bar (not included)	198	498	81 x 7	7,10	840515

ACO Xtraline S 150 grating accessories

Image	Description	Material	Valid for	Article number
	Bolt and bar kit + M8x40 TBL combi screw	Galvanized steel	ACO Xtraline S 150 galvanized steel gratings	840818 ⁽¹⁾
		Stainless steel	ACO Xtraline S 150 stainless steel gratings	840819 ⁽¹⁾

⁽¹⁾Valid for 1 meter of channel

ACO Xtraline S 200

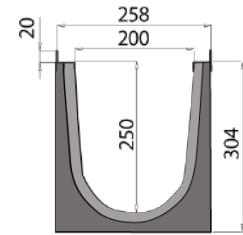
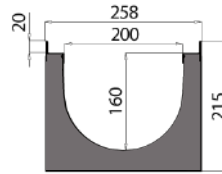
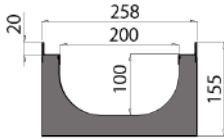
Product information

- Plastic drainage channel, internal width: 200 mm
- Galvanized steel or stainless steel rail
- For load classes: B 125 – C 250, according to EN 1433 norm
- Equipped with sump unit and foul air trap
- Side and vertical knockouts
- Bolt and bar fixing system for gratings
- Availability of special parts for corners, T-couplings and cross-couplings







ACO Xtraline S 200 channel with galvanized/stainless steel rail

Length 1000 mm, total width 258 mm

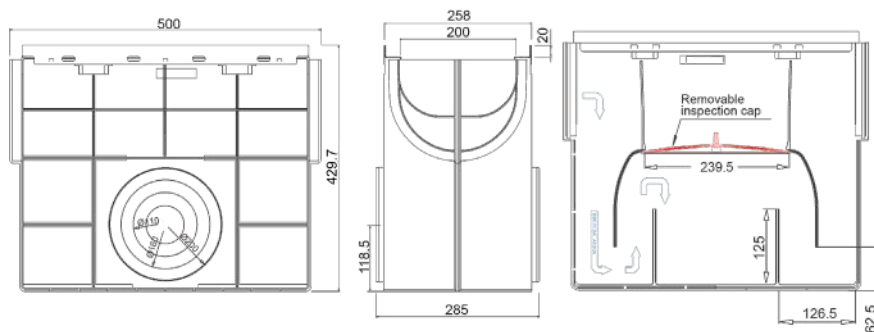


Total Height [mm]	Internal height [mm]	Ø side outlet [mm]	Ø vertical outlet [mm]	Weight [kg/pc]	Pieces/pallet	Stainless steel	Galvanized steel
						Article number	Article number
Channel with vertical outlet Ø200/160							
155	100	2 x Ø63	1 x Ø200/160	4,35	32	840237	840234
215	160	2 x Ø110	1 x Ø200/160	4,95	24	840238	840235
304	250	2 x Ø160/200	1 x Ø200/160	6,30	16	840239	840236

ACO Xtraline S 200 channel accessories

Image	Description	For channel internal height [mm]	Material	Article number
	Closed end-cap	100	PE	840919
		160	PE	840920
	Ø75 outlet end-cap	100	PE	840950
	Ø110 outlet end-cap	160	PE	840923
	Closed end-cap with Ø160 knockout	250	PE	840924
	Step connectors from 100 mm to 160 mm		Composit	840917
	Step connectors from 160 mm to 250 mm	-	Composit	840918



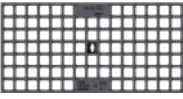



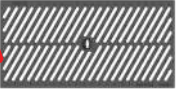
ACO Xtraline S 200 sump unit with galvanized/stainless steel rail



Description	Material	Height [mm]	Width [mm]	Length [mm]	Ø side outlet [mm]	Weight [kg/pc]	Stainless steel	Galvanized steel
							Article number	Article number
Sump unit with female-female connection	PE	429,7	258	500	2xØ110 2xØ160 2xØ200	3,85	840938 ⁽¹⁾	840937 ⁽¹⁾



⁽¹⁾Not valid for channel height 250

ACO Xtraline S 200 channel gratings

Image	Description	Fixing system	Width [mm]	Length [mm]	Slot/Mesh [mm]	Weight [kg/pc]	Article number
B 125							
	Galvanized steel heel safe mesh	Bolt and bar (not included)	248	998	33 x 15	6,20	840452
	Stainless steel heel safe mesh	Bolt and bar (not included)	248	998	33 x 15	6,20	840458
	Galvanized steel square mesh	Bolt and bar (not included)	248	998	32,2 x 32,2	5,20	840453
	Stainless steel square mesh	Bolt and bar (not included)	248	998	32,2 x 32,2	5,20	840459
	Ductile iron grating mesh	Bolt and bar (not included)	248	498	25,5 x 24,5	6,25	840454
	Ductile iron 7mm slot	Bolt and bar (not included)	248	498	107 x 7	7,70	840457
C 250							
	Galvanized steel heel safe mesh	Bolt and bar (not included)	248	998	33 x 15	9,50	840455
	Stainless steel heel safe mesh	Bolt and bar (not included)	248	998	33 x 15	9,50	840460
	Ductile iron 20mm Slot	Bolt and bar (not included)	248	498	180 x 20	7,00	840456
	Ductile iron 8mm slot	Bolt and bar (not included)	248	498	107 x 7	9,00	840516

NEW

ACO Xtraline S 200 grating accessories

Image	Description	Material	Valid for	Article number
	Bolt and bar kit + M8x40 TBL combi screw	Galvanized steel	ACO Xtraline S 200 galvanized steel gratings	840815 ⁽¹⁾
		Stainless steel	ACO Xtraline S 200 stainless steel gratings	840816 ⁽¹⁾
	Bolt and bar kit + M8x40 black hex head screw	Galvanized steel	ACO Xtraline S 200 ductile iron gratings	840817 ⁽¹⁾

⁽¹⁾Valid for 1 meter of channel



4 ACO Xtraline C
Drainage channel

COLLECT:
Collect and convey



ACO Xtraline C – Plastic drainage channels

ACO Xtraline C 100	Channel	P. 50
	Accessories	P. 51
	Sump unit	P. 51
	Gratings and accessories	P. 52
ACO Xtraline C 150	Channel	P. 54
	Accessories	P. 55
	Sump unit	P. 55
	Gratings and accessories	P. 56
ACO Xtraline C 200	Channel	P. 58
	Accessories	P. 59
	Sump unit	P. 59
	Gratings and accessories	P. 60
ACO Xtraline C 300	Channel	P. 61
	Accessories	P. 61
	Gratings and accessories	P. 62



Declaration of performance:
www.aco.it/download/dop

Flexibility of the channel system, wide variety of gratings

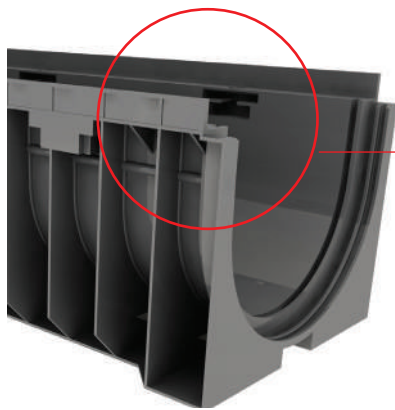
ACO Xtraline C is a practical and flexible drainage system. The channel body is completely made of high-density polyethylene with an inbuilt rail that ensures protection to the gratings, even without steel.

The large range of gratings makes it possible to customize the drainage line; different designs and, multiple material like galvanized steel, stainless steel, ductile iron, PP-PE and polyamide are all available.

L-shaped SlotTops are available on request.

This product range is particularly suitable for civil applications, pedestrian areas and private parking areas.

The ACO Xtraline C 300, with an internal width of 300 mm and 1.5 meters length, is the best solution for large surface drainage applications.

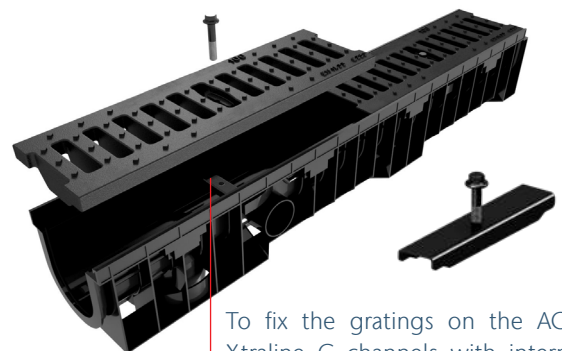


The 20 mm high HD-PE Rail (35 mm for ACO Xtraline C 300) contains and limits the grating, making it easier and comfortable to install.



Main Features

- The channel body is completely made of plastic, certified for load class A 15, B 125 and C 250 according to EN 1433: 2008
- With HD-PE integrated rail
- 4 different nominal widths: 100, 150, 200, 300 mm
- With vertical and lateral knockouts
- Vertical outlet kit Ø100 and Ø110 mm for channels H 55 and H 80 mm
- Sump unit with foul air trap
- Galvanized/stainless steel brickslots available on request
- Bolt and bar fixing system for the gratings
- Special parts for corners, T-couplings and Cross-couplings available



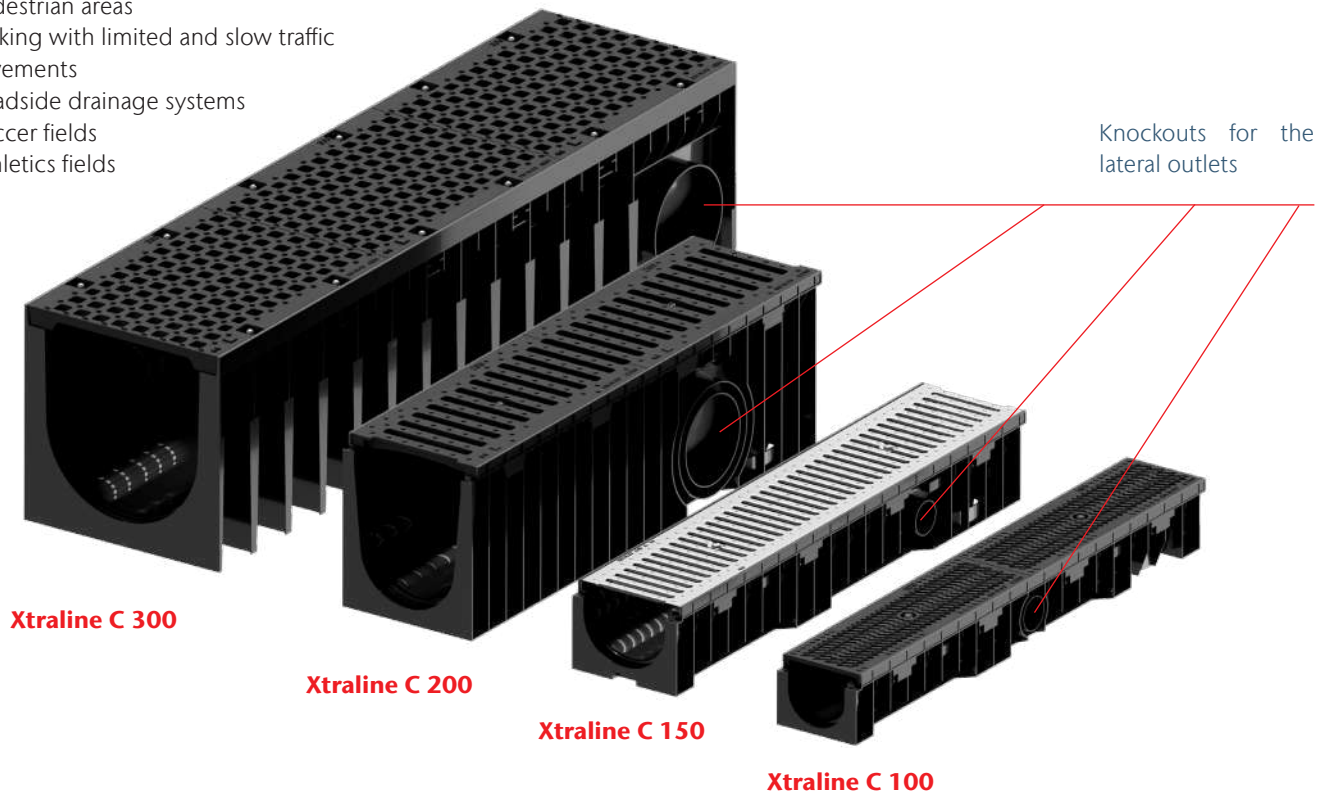
To fix the gratings on the ACO Xtraline C channels with internal width 100, 150 and 200 mm, you will need one bar and bolt every half meter of channel.

To fix the grating on the ACO Xtraline C 300 channels, you will need 4 nuts for every half meter of channel.

ACO Xtraline C

Typical applications

- Residential areas
- Pedestrian areas
- Parking with limited and slow traffic
- Pavements
- Roadside drainage systems
- Soccer fields
- Athletics fields



Polyamide grating detail



ACO Xtraline C 100

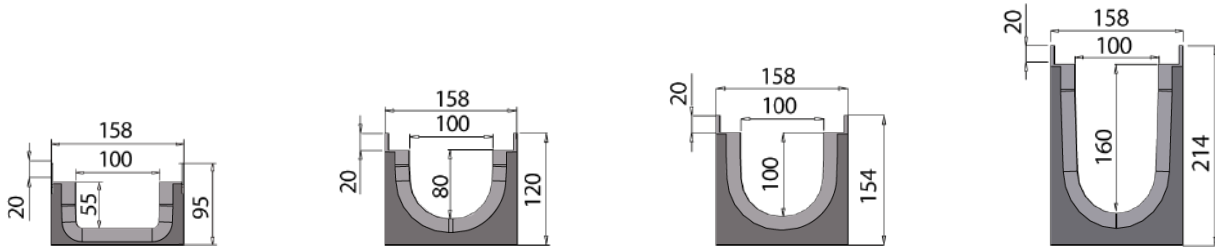
Product information

- Plastic drainage channel, internal width: 100 mm
- HD-PE rail
- For load classes: A 15, B 125 and C 250, according to EN 1433 norm
- Sump unit with foul air trap
- Side and vertical knockouts
- Vertical outlet kit Ø100 and Ø110 mm for channels H 55 and H 80 mm; knockouts on all other sizes
- Wide range of gratings
- Galvanized/stainless steel brickslots available on request
- Bolt and bar fixing system for the gratings
- Special parts for corners, T-couplings and cross-couplings are available







ACO Xtraline C 100 channel

Length 1000 mm, total width 158 mm

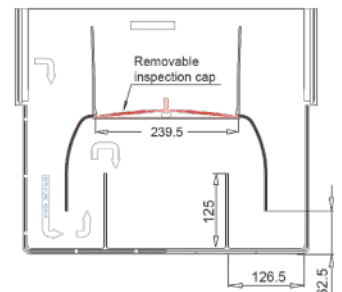
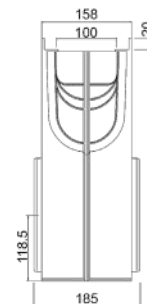
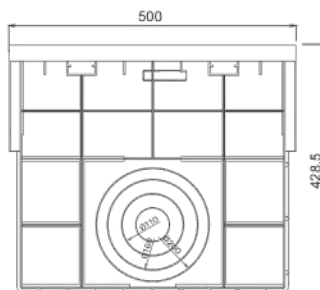


Total height	Internal height	Ø side outlet	Ø vertical outlet	Weight	Pieces/pallet	Article number
[mm]	[mm]	[mm]	[mm]	[kg/pc]		
Channel with vertical outlet kit Ø100/110						
95	55	2 x Ø40	1 x Ø100/110	1,56	84	840212
120	80	2 x Ø63	1 x Ø100/110	1,70	70	840213
Channel with vertical outlet Ø110						
154	100	2 x Ø63	1 x Ø110	2,05	56	840214
214	160	2 x Ø110	1 x Ø110	2,55	42	840215

ACO Xtraline C 100 channel accessories



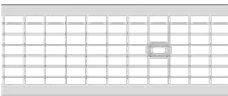
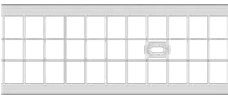







Image	Description	For channel internal height [mm]	Material	Article number
	Closed end-cap	55	PE	840904
		80	PE	840905
		100	PE	840906
		160	PE	840907
	Ø40 outlet end-cap	55	PE	840900
	Ø50 outlet end-cap	80	PE	840946
	Ø75 outlet end-cap	100	PE	840947
		160	PE	840948
	KIT Ø100 vertical outlet	55/80	PE	840909
	KIT Ø110 vertical outlet	55/80	PE	840910
	Step connectors from 100 mm to 160 mm	-	Composit	840908

ACO Xtraline C 100 sump unit with PE rail





Description	Material	Height [mm]	Width [mm]	Length [mm]	Ø side outlet [mm]	Weight [kg/pc]	Article number
Sump unit with female- female connection	PE	428,5	158	500	2xØ110 2xØ160 2xØ200	2,60	840930

ACO Xtraline C 100 channel gratings

Image	Description	Fixing system	Width	Length	Slot/mesh	Weight	Article number
			[mm]	[mm]	[mm]	[kg/pc]	
Pedestrian							
	PP-PE mesh	Lateral plastic hook	148	498	34 x 8.5	0,44	840419
A 15							
	Galvanized steel slot	Bolt and bar (not included)	148	998	83 x 8.5	1,60	840418
	Stainless steel slot	Bolt and bar (not included)	148	998	83 x 8.5	1,60	840420
B 125							
	Galvanized steel heel safe mesh	Bolt and bar (not included)	148	998	33 x 15	3,60	840429
	Stainless steel heel safe mesh	Bolt and bar (not included)	148	998	33 x 15	3,60	840436
	Galvanized steel square mesh	Bolt and bar (not included)	148	998	32,2 x 32,2	2,90	840430
	Stainless steel square mesh	Bolt and bar (not included)	148	998	32,2 x 32,2	2,90	840437
	Ductile iron mesh	Bolt and bar (not included)	148	498	21,5 x 17,5	3,40	840431
	Polyamide 16 mm slot	Bolt and bar (not included)	148	498	82 x 20	0,80	840510
C 250							
	Galvanized steel heel safe mesh	Bolt and bar (not included)	148	998	33 x 15	5,10	840432
	Stainless steel heel safe mesh	Bolt and bar (not included)	148	998	33 x 15	5,10	840438
	Ductile iron 7 mm slot	Bolt and bar (not included)	148	498	57 x 7	4,10	840439
	Ductile iron 20 mm slot	Bolt and bar (not included)	148	498	82 x 20	3,60	840434
	Ductile iron mesh	Bolt and bar (not included)	148	498	21,5 x 17,5	3,80	840433
	Polyamide 16 mm slot	Bolt and bar (not included)	148	498	82 x 20	1,30	840511

ACO Xtraline C 100 grating accessories

Image	Description	Material	Valid for	Article number
	Bolt and bar kit + M8x55 TBL combi bolt	Galvanized steel	ACO Xtraline C 100 galvanized steel gratings	840821 ⁽¹⁾
		Stainless steel	ACO Xtraline C 100 stainless steel gratings	840822 ⁽¹⁾
	Bolt and bar kit + M8x55 black hex head bolt	Galvanized steel	ACO Xtraline C 100 ductile iron gratings	840823 ⁽¹⁾

⁽¹⁾Valid for 1 meter of channel

ACO Xtraline C 150

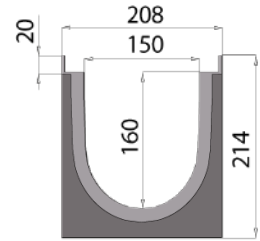
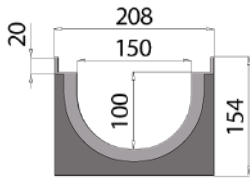
Product information

- Plastic drainage channel, internal width: 150 mm
- HD-PE rail
- For load classes: A15, B125 and C250, according to EN 1433 norm
- Sump Unit with foul air trap
- Side and vertical knockouts
- Wide range of gratings
- Galvanized/stainless steel brickslots available on request
- Bolt and bar fixing system for the gratings
- Special parts for corners, T-couplings and cross-couplings are available






ACO Xtraline C 150 channel

Length 1000 mm, total width 208 mm

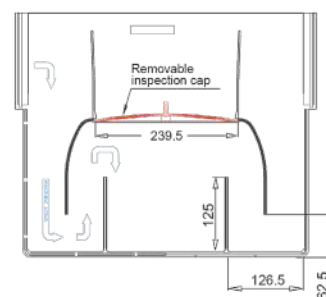
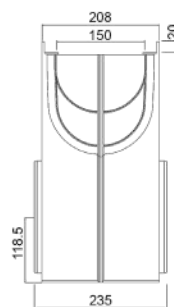
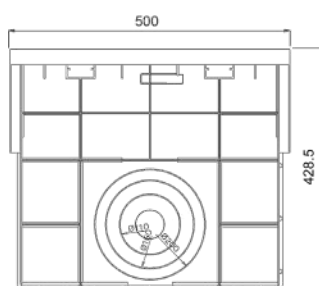


Total height	Internal height	Ø side outlet	Ø vertical outlet	Weight	Pieces/pallet	Article number
[mm]	[mm]	[mm]	[mm]	[kg/pc]		
Channel with vertical outlet Ø110/160						
154	100	2 x Ø63	1 x Ø110/160	2,45	40	840216
214	160	2 x Ø110	1 x Ø110/160	3,00	30	840217

ACO Xtraline C 150 channel accessories

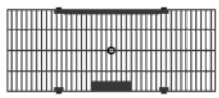


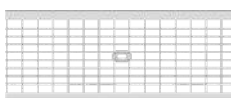



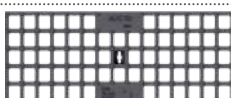


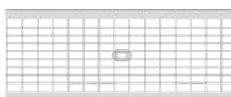


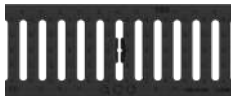
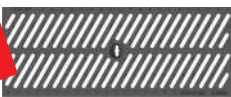
Image	Description	For channel internal height [mm]	Material	Article number
	Closed end-cap	100	PE	840912
		160	PE	840913
	Ø75 outlet end-cap	100	PE	840949
	Ø110 outlet end-cap	160	PE	840916
	Step connectors from 100 mm to 160 mm		Composit	840911

ACO Xtraline C 150 sump unit with PE rail





Description	Material	Height [mm]	Width [mm]	Length [mm]	Ø side outlet [mm]	Weight [kg/pc]	Article number
Sump unit with female- female connection	PE	428,5	208	500	2xØ110 2xØ160 2xØ200	2,85	840931

ACO Xtraline C 150 channel gratings

Image	Description	Fixing system	Width	Length	Slot/mesh	Weight	Article number
			[mm]	[mm]	[mm]	[kg/pc]	
Pedestrian							
	PP-PE mesh	Lateral plastic hook	198	498	34 x 8.5	0,82	840422
A 15							
	Galvanized steel slot	Bolt and bar (not included)	198	998	130 x 8.5	2,90	840421
	Stainless steel slot	Bolt and bar (not included)	198	998	130 x 8.5	2,90	840423
B 125							
	Galvanized steel heel safe mesh	Bolt and bar (not included)	198	998	33 x 15	5,30	840442
	Stainless steel heel safe mesh	Bolt and bar (not included)	198	998	33 x 15	5,00	840448
	Galvanized steel square mesh	Bolt and bar (not included)	198	998	32,2 x 32,2	4,10	840443
	Stainless steel square mesh	Bolt and bar (not included)	198	998	32,2 x 32,2	4,10	840449
	Ductile iron mesh	Bolt and bar (not included)	198	498	29 x 24,5	4,90	840444
	Polyamide 16mm slot	Bolt and bar (not included)	198	498	132 x 16	1,70	840424
	Slot 7mm ductile iron	Bolt and bar (not included)	198	498	81 x 7	5,97	840447
C 250							
	Galvanized steel heel safe mesh	Bolt and bar (not included)	198	998	33 x 15	7,50	840445
	Stainless steel heel safe mesh	Bolt and bar (not included)	198	998	33 x 15	7,50	840450
	Ductile iron 20mm slot	Bolt and bar (not included)	198	498	132 x 20	5,30	840446
	Polyamide 16mm slot	Bolt and bar (not included)	198	498	132 x 16	2,35	840451
	Slot 8mm ductile iron	Bolt and bar (not included)	198	498	81 x 7	9,00	840515

NEW

ACO Xtraline C 150 grating accessories

Image	Description	Material	Valid for	Article number
	Bolt and bar kit + M8x55 TBL combi bolt	Galvanized steel	ACO Xtraline C 150 galvanized steel gratings	840818 ⁽¹⁾
		Stainless steel	ACO Xtraline C 150 stainless steel gratings	840819 ⁽¹⁾
	Bolt and bar kit + M8x55 black hex head bolt	Galvanized steel	ACO Xtraline C 150 ductile iron gratings	840820 ⁽¹⁾

⁽¹⁾Valid for 1 meter of channel

ACO Xtraline C 200

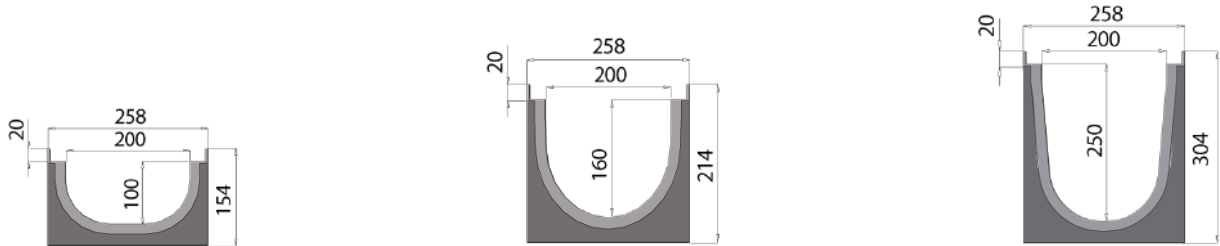
Product information

- Plastic drainage channel, internal width: 200 mm
- HD-PE rail
- For load classes: A 15, B 125 and C 250, according to EN 1433 norm
- Sump unit with foul air trap
- Side and vertical knockouts
- Wide range of gratings
- Galvanized/stainless steel brickslots available on request
- Bolt and bar fixing system for the gratings
- Special parts for corners, T-couplings and cross-couplings are available







ACO Xtraline C 200 channel with HD-PE rail

Length 1000 mm, total width 258 mm

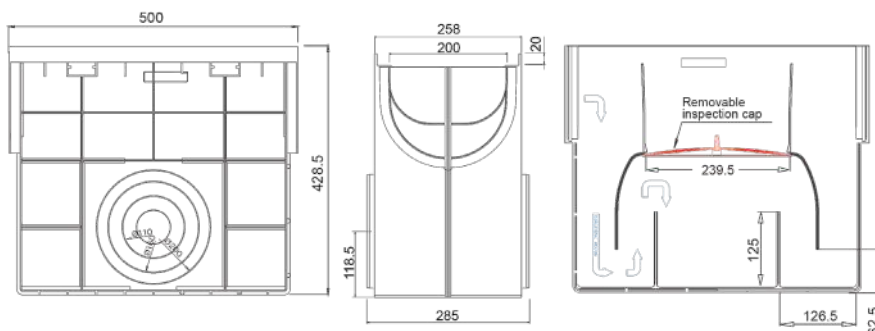


Total height	Internal height	Ø side outlet	Ø vertical outlet	Weight	Pieces/pallet	Article number
[mm]	[mm]	[mm]	[mm]	[kg/pz]		
Channel with vertical outlet Ø200/160						
154	100	2 x Ø63	1 x Ø200/160	2,80	32	840218
214	160	2 x Ø110	1 x Ø200/160	3,40	24	840219
304	250	2 x Ø160/200	1 x Ø200/160	5,00	16	840220

ACO Xtraline C 200 channel accessories

Image	Description	For channel internal height [mm]	Material	Article number
	Closed end-cap	100	PE	840919
		160	PE	840920
	Ø75 outlet end-cap	100	PE	840950
	Ø110 outlet end-cap	160	PE	840923
	Closed end-cap with Ø160 knockout	250	PE	840924
	Step connectors from 100 mm to 160 mm	-	Composit	840917
	Step connectors from 160 mm to 250 mm	-	Composit	840918

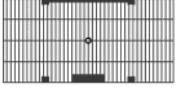







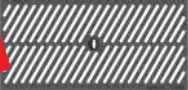
ACO Xtraline C 200 sump unit with PE rail



Description	Material	Height [mm]	Width [mm]	Length [mm]	Ø side outlet [mm]	Weight [kg/pc]	Article number
Sump unit with female-female connection	PE	428,5	258	500	2xØ110 2xØ160 2xØ200	3,10	840932 ⁽¹⁾


⁽¹⁾It is not designed for connection to H250 channels

ACO Xtraline C 200 channel gratings

Image	Description	Fixing System	Width [mm]	Length [mm]	Slot/Mesh [mm]	Weight [kg/pc]	Article number
Pedestrian							
	PP-PE mesh	Lateral plastic hook	248	498	58,5 x 8,5	1,06	840426
A 15							
	Galvanized steel slot	Bolt and bar (not included)	248	998	130 x 8,5	4,80	840425
	Stainless steel slot	Bolt and bar (not included)	248	998	130 x 8,5	4,90	840427
B 125							
	Galvanized steel heel safe mesh	Bolt and bar (not included)	248	998	33 x 15	6,20	840452
	Stainless steel heel safe mesh	Bolt and bar (not included)	248	998	33 x 15	6,20	840458
	Galvanized steel square mesh	Bolt and bar (not included)	248	998	32,2 x 32,2	5,20	840453
	Stainless steel square mesh	Bolt and bar (not included)	248	998	32,2 x 32,2	5,20	840459
	Ductile iron mesh	Bolt and bar (not included)	248	498	25,5 x 24,5	6,25	840454
	Ductile iron 7mm slot	Bolt and bar (not included)	248	498	107 x 7	7,70	840457
C 250							
	Galvanized steel heel safe mesh	Bolt and bar (not included)	248	998	33 x 15	9,50	840455
	Stainless steel heel safe mesh	Bolt and bar (not included)	248	998	33 x 15	9,50	840460
	Ductile iron 20mm slot	Bolt and bar (not included)	248	498	180 x 20	7,00	840456
	Ductile iron 8mm slot	Bolt and bar (not included)	248	498	107 x 7	9,00	840516

NEW

ACO Xtraline C 200 grating accessories

Image	Description	Material	Valid for	Article number
	Bolt and bar kit + M8x55 TBL combi bolt	Galvanized steel	ACO Xtraline C 200 galvanized steel gratings	840815 ⁽¹⁾
		Stainless steel	ACO Xtraline C 200 stainless steel gratings	840816 ⁽¹⁾

⁽¹⁾Valid for 1 meter of channel

ACO Xtraline C 300

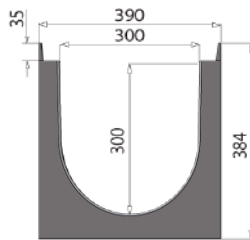
Product information

- Plastic drainage channel, internal width: 300 mm
- HD-PE rail
- For load classes: A 15, B 125 and C 250, according to EN 1433 norm
- 1500 mm long elements
- Grating fixed with 8 nuts per meter
- With lateral and vertical knockout





ACO Xtraline C 300 channel with HD-PE rail

Length 1500 mm, total width 390 mm

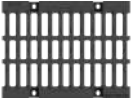
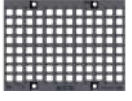


Total height	Internal height	Ø side outlet	Ø vertical outlet	Weight	Article number
[mm]	[mm]	[mm]	[mm]	[kg/pc]	
384	300	2 x Ø200	1 x Ø160, 1 x Ø200	9,30	840221


ACO Xtraline C 300 channel accessories

Image	Description	For channel internal height [mm]	Material	Article number
	Closed end-cap	300	Galvanized steel	840926
	Ø200 outlet end-cap	300	Galvanized steel	840925

ACO Xtraline C 300 channel gratings

Image	Description	Fixing system	Width [mm]	Length [mm]	Slot/mesh [mm]	Weight [kg/pc]	Article number
B 125							
	Ductile iron slot mesh	8 bolt/meter (not included)	376	498	90 x 25	13,00	840485
C 250							
	Ductile iron square mesh	8 bolt/meter (not included)	376	498	25 x 25	16,50	840428

ACO Xtraline C 300 grating accessories

Image	Description	Material	Valid for	Article number
	Blind M8 nut	Galvanized steel	ACO Xtraline C 300 ductile iron gratings	840813 ⁽¹⁾
		Stainless steel	ACO Xtraline C 300 ductile iron gratings	840814 ⁽¹⁾

⁽¹⁾Valid for 1,5 meter of channel



5

ACO Xtraline Drainage channel

COLLECT:
Collect and convey



ACO Xtraline – Plastic drainage channels

	Channel	P. 68
ACO Xtraline 100	Channel accessories	P. 69
	Sump unit	P. 69
	Gratings and accessories	P. 70
	Channel	P. 71
ACO Xtraline 150	Channel accessories	P. 72
	Sump unit	P. 72
	Gratings and accessories	P. 73
	Channel	P. 74
ACO Xtraline 200	Channel accessories	P. 75
	Sump unit	P. 75
	Gratings and accessories	P. 76



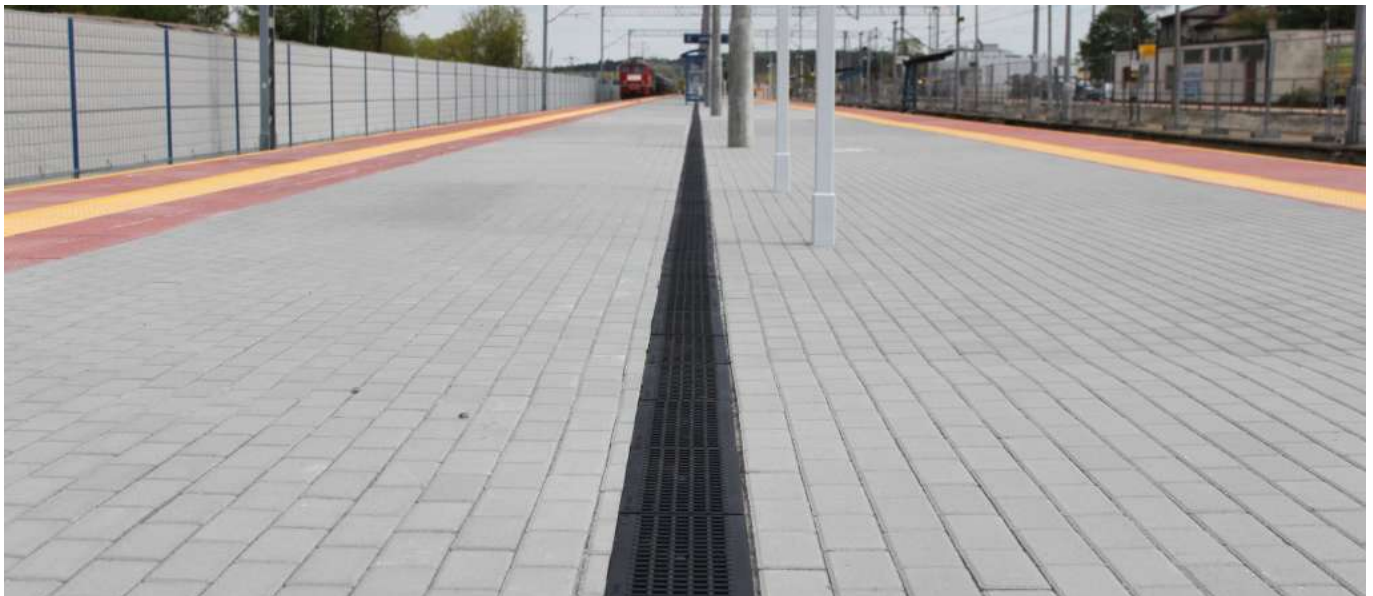
Declaration of performance:
www.aco.it/download/dop

ACO Xtraline, the installation in residential contexts

ACO Xtraline is the linear drainage system completely made of HD-PE with no rails.

The absence of rail ensures that the grating completely covers the channel and allows a drainage line installation without interruptions or discontinuities; this, many times, increases the aesthetics of installation in architectural projects and contexts.

The absence of any rail is a plus when it gets to height reduction in difficult installation sites and makes it possible to install the channel in all areas with reduced excavation depth.



Main features

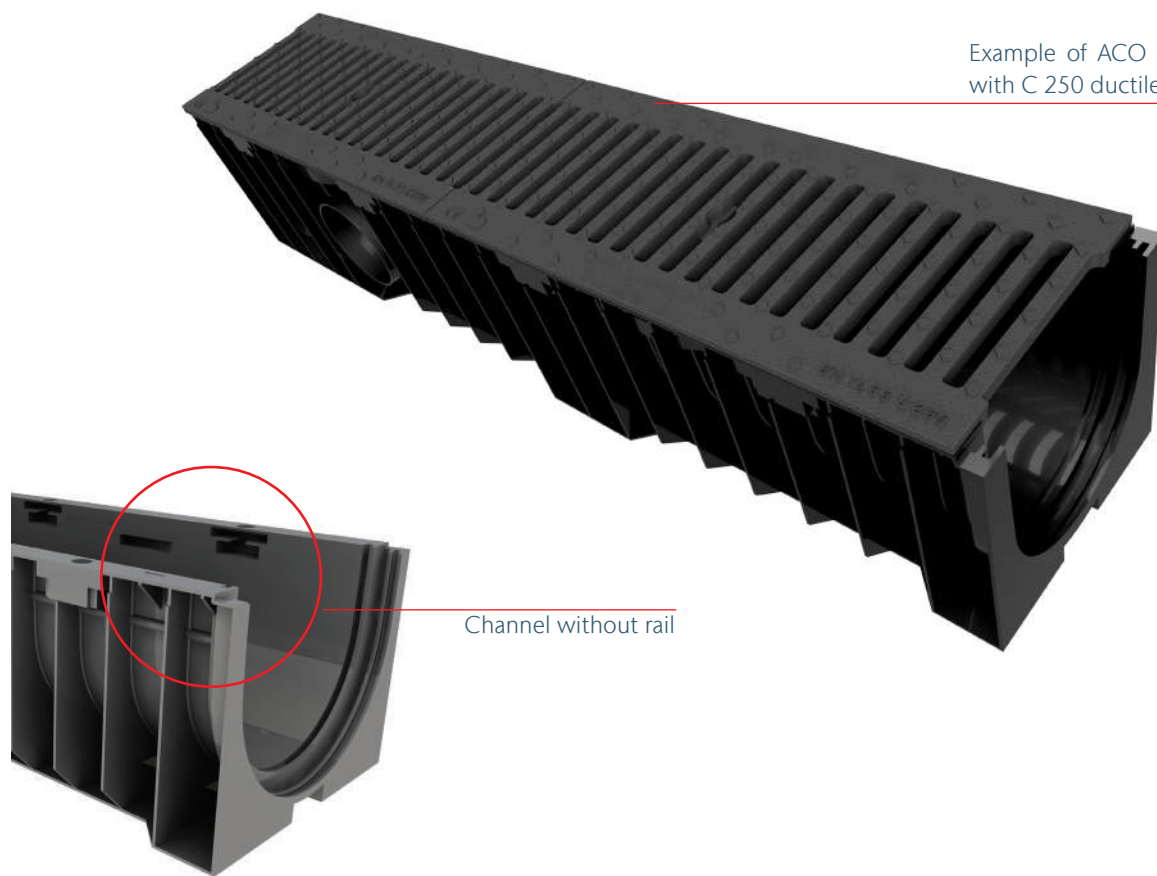
- Channel body completely made of plastic
- The grating covers completely the channel body
- 3 different internal widths: 100, 150, 200 mm are available
- Sump unit with foul air trap
- With side and vertical knockouts
- Vertical outlet kit Ø100 and Ø110 mm for channels H55 and H80 mm
- Galvanized/stainless steel brickslots available on request
- Bolt and bar fixing system for the gratings.
- Special pieces for corners, “T” couplings and cross couplings are available
- End-caps or end-caps with outlets

Typical applications

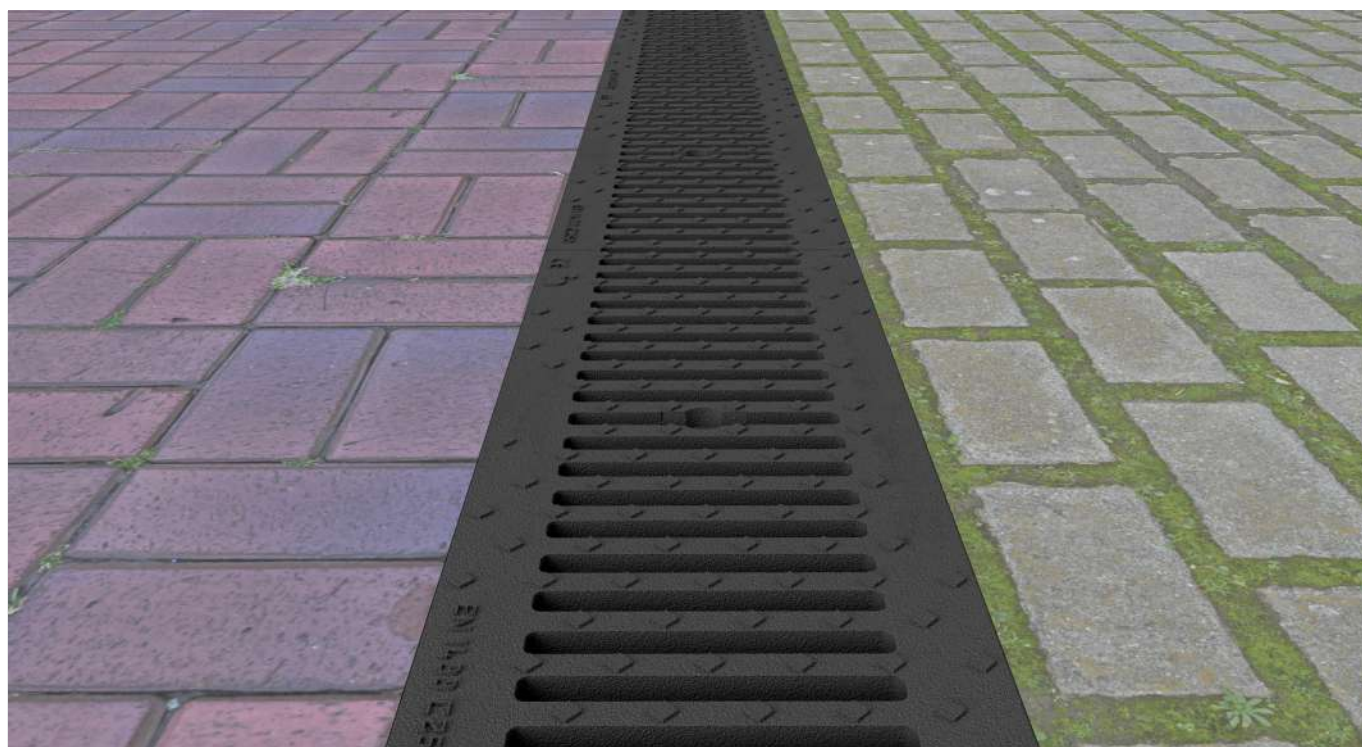
- Domestic and civil use
- Pedestrian areas
- Cycle paths
- Gardens
- Sports facilities
- Terraces and flat roofs
- Multi-level car parking

System overview

Example of ACO Xtraline 150 channel with C 250 ductile iron slot grating



Detail of the installed channel



ACO Xtraline 100

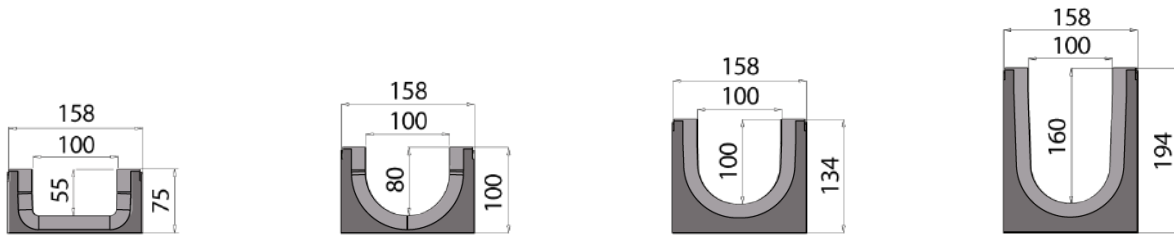
Product information

- Plastic drainage channel, internal width: 100 mm
- Suitable for load classes: A 15, B 125 and C 250, according to EN 1433 norm
- Sump unit with foul air trap
- Side and vertical knockouts
- Vertical outlet kit Ø100 and Ø110 mm for channels H 55 and H 80 mm
- Wide range of gratings
- Special parts for corners, T-couplings and cross-couplings are available






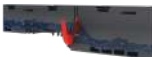
ACO Xtraline 100 channel

Length 1000 mm, total width 158 mm

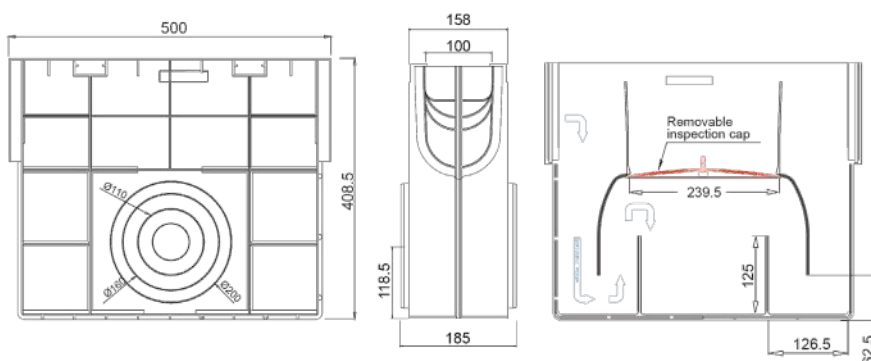


Total height	Internal height	Ø side outlet	Ø Vertical outlet	Weight	Pieces/pallet	Article number
[mm]	[mm]	[mm]	[mm]	[kg/pc]		
Channel with vertical outlet kit Ø100/110						
75	55	2 x Ø40	1 x Ø100/110	1,40	98	840240
100	80	2 x Ø63	1 x Ø100/110	1,60	70	840241
Channel with vertical outlet Ø110						
134	100	2 x Ø63	1 x Ø110	1,90	56	840242
194	160	2 x Ø110	1 x Ø110	2,40	42	840243

ACO Xtraline 100 channel accessories

Image	Description	For channel internal height [mm]	Material	Article number
	Closed end-cap	55	PE	840904
		80	PE	840905
		100	PE	840906
		160	PE	840907
	Ø40 outlet end-cap	55	PE	840900
	Ø50 outlet end-cap	80	PE	840946
	Ø75 outlet end-cap	100	PE	840947
		160	PE	840948
	Vertical outlet KIT Ø100	55/80	PE	840909
	Vertical outlet KIT Ø110	55/80	PE	840910
	Step connectors from 100 mm to 160 mm	-	Composit	840908

ACO Xtraline 100 sump unit





Description	Material	Height [mm]	Width [mm]	Length [mm]	Ø side outlet [mm]	Weight [kg/pc]	Article number
Sump unit with female-female connection	PE	408,5	158	500	2xØ110 2xØ160 2xØ200	2,50	840939

ACO Xtraline 100 channel gratings

Image	Description	Fixing system	Width [mm]	Length [mm]	Slot/mesh [mm]	Weight [kg/pc]	Article number
A 15							
	Galvanized steel slot	Bolt and bar (not included)	154	998	83 x 8,5	1,80	840461
	Stainless steel slot	Bolt and bar (not included)	154	998	83 x 8,5	1,80	840465
B 125							
	Galvanized steel heel safe mesh	Bolt and bar (not included)	154	998	33 x 15	3,90	840462
	Stainless steel heel safe mesh	Bolt and bar (not included)	154	998	33 x 15	3,90	840466
	Galvanized steel square mesh	Bolt and bar (not included)	154	998	34,2 x 32,2	3,30	840468
	Stainless steel square mesh	Bolt and bar (not included)	154	998	34,2 x 32,2	3,30	840467
	Ductile iron mesh	Bolt and bar (not included)	154	498	21,5 x 17,5	3,00	840463
C 250							
	Ductile iron 13mm Slot	Bolt and bar (not included)	154	498	80,0 x 13,0	4,20	840464

ACO Xtraline 100 gratings accessories

Image	Description	Material	Valid for	Article number
	Bolt and bar kit + M8x40 TBL combi screw	Galvanized steel	ACO Xtraline 100 galvanized steel gratings	840800 ⁽¹⁾
		Stainless steel	ACO Xtraline 100 stainless steel gratings	840801 ⁽¹⁾
	Bolt and bar kit + M8x40 black hex head screw	Galvanized steel	ACO Xtraline 100 ductile iron gratings	840802 ⁽¹⁾

⁽¹⁾Valid for 1 meter of channel

ACO Xtraline 150

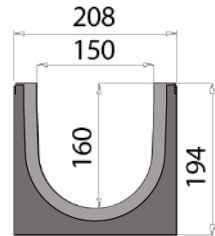
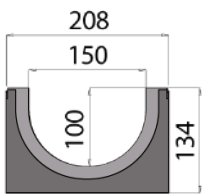
Product information

- Plastic drainage channel, internal width: 150 mm
- Suitable for load classes: A 15, B 125 and C 250, according to EN 1433 norm
- Sump unit with foul air trap
- Side and vertical knockouts
- Wide range of gratings
- Special parts for corners, T-couplings and cross-couplings are available






ACO Xtraline 150 channel

Length 1000 mm, total width 208 mm

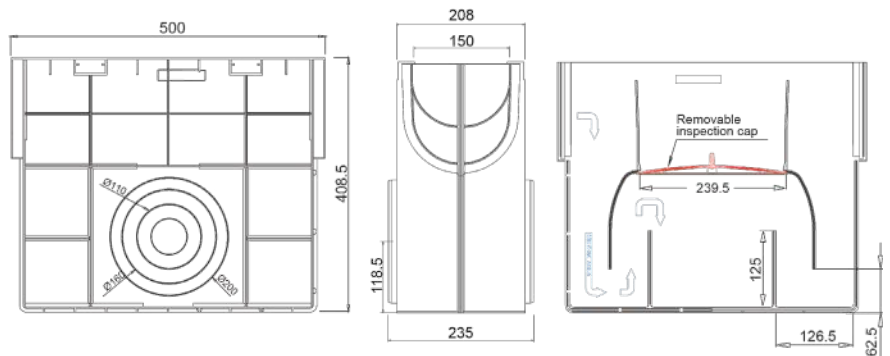


Total height	Internal height	Ø Side outlet	Ø Vertical outlet	Weight	Pieces/pallet	Article number
[mm]	[mm]	[mm]	[mm]	[kg/pc]		
Channel with Vertical outlet Ø110/160						
134	100	2 x Ø63	1 x Ø110/160	2,30	40	840244
194	160	2 x Ø110	1 x Ø110/160	2,85	30	840245

Accessories for ACO Xtraline 150 channel


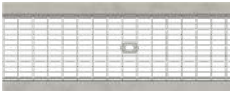
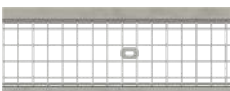
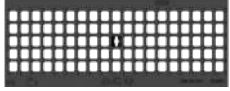

Image	Description	For channel internal height [mm]	Material	Article number
	Closed end-cap	100	PE	840912
		160	PE	840913
	Ø75 outlet end-cap	100	PE	840949
	Ø110 outlet end-cap	160	PE	840916
	Step connectors from 150/100 to 150/160	-	Composit	840911

ACO Xtraline 150 sump unit





Description	Material	Height [mm]	Width [mm]	Length [mm]	Ø Side Outlet [mm]	Weight [kg/pc]	Article Number
Sump unit with female-female connection	PE	408,5	208	500	2xØ110 2xØ160 2xØ200	2,78	840940

ACO Xtraline 150 channel gratings

Image	Description	Fixing System	Width [mm]	Length [mm]	Slot/Mesh [mm]	Weight [kg/pc]	Article Number
A 15							
	Galvanized steel slot	Bolt and bar (not included)	204	998	130 x 8.5	3,00	840469
	Stainless steel slot	Bolt and bar (not included)	204	998	130 x 8.5	3,30	840473
B 125							
	Galvanized steel heel safe mesh	Bolt and bar (not included)	204	998	33 x 15	5,40	840470
	Stainless steel heel safe mesh	Bolt and bar (not included)	204	998	33 x 15	5,40	840474
	Galvanized steel square mesh	Bolt and bar (not included)	204	998	34,2 x 32,2	4,60	840476
	Stainless steel square mesh	Bolt and bar (not included)	204	998	34,2 x 32,2	4,60	840475
	Ductile iron mesh	Bolt and bar (not included)	204	498	21.5 x 17,5	4,70	840471
C 250							
	Ductile iron 13 mm Slot	Bolt and bar (not included)	204	498	130 x 13	5,50	840472

ACO Xtraline 150 grating accessories

Image	Description	Material	Valid for	Article Number
	Bolt and bar kit + M8x40 TBL combi screw	Galvanized steel	ACO Xtraline 150 galvanized steel gratings	840803 ⁽¹⁾
		Stainless steel	ACO Xtraline 150 stainless steel gratings	840804 ⁽¹⁾
	Bolt and bar kit + M8x40 black hex head screw	Galvanized steel	ACO Xtraline 150 ductile iron gratings	840805 ⁽¹⁾

⁽¹⁾Valid for 1 meter of channel

ACO Xtraline 200

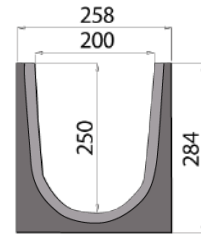
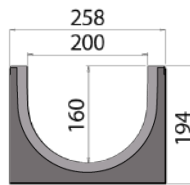
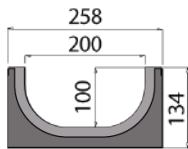
Product information

- Plastic drainage channel, internal width: 200 mm
- Suitable for load classes: A 15, B 125 and C 250, according to EN 1433 norm
- Sump unit with foul air trap
- Side and vertical knockouts
- Wide range of gratings
- Special parts for corners, T-couplings and cross-couplings are available







ACO Xtraline 200 channel

Length 1000 mm, total width 258 mm

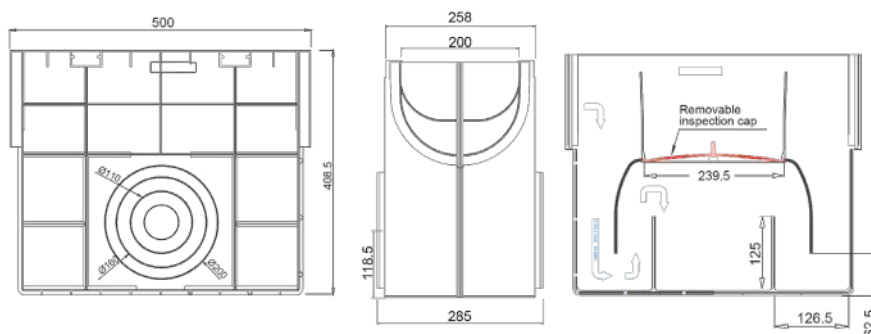


Total height	Internal height	Ø side outlet	Ø Vertical outlet	Weight	Pieces/pallet	Article number
[mm]	[mm]	[mm]	[mm]	[kg/pc]		
Channel with Vertical outlet Ø200/160						
134	100	2 x Ø63	1 x Ø200/160	2,65	32	840246
194	160	2 x Ø110	1 x Ø200/160	3,25	24	840247
284	250	2 x Ø160/200	1 x Ø200/160	4,80	16	840248

ACO Xtraline 200 channel accessories

Image	Description	For channel internal height [mm]	Material	Article number
	Closed end-cap	100	PE	840919
		160	PE	840920
	Ø75 outlet end-cap	100	PE	840950
	Ø110 outlet end-cap	160	PE	840923
	Closed end-cap with Ø160 knockout	250	PE	840924
	Step connectors from 100 mm to 160 mm	-	Composit	840917
	Step connectors from 160 mm to 250 mm	-	Composit	840918


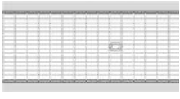
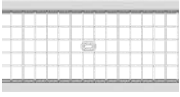
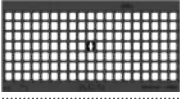
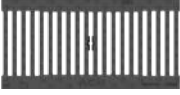
ACO Xtraline 200 sump unit





Description	Material	Height [mm]	Width [mm]	Length [mm]	Ø side outlet [mm]	Weight [kg/pc]	Article number
Sump unit with female-female connection	PE	408,5	258	500	2xØ110 2xØ160 2xØ200	3,00	840941 ⁽¹⁾

⁽¹⁾It is not designed for connection to H250 channels

ACO Xtraline 200 gratings

Image	Description	Fixing system	Width [mm]	Length [mm]	Slot/Mesh [mm]	Weight [kg/pc]	Article number
A 15							
	Galvanized steel slot	Bolt and bar (not included)	254	998	130 x 8.5	5,00	840477
	Stainless steel slot	Bolt and bar (not included)	254	998	130 x 8.5	3,90	840482
B 125							
	Galvanized steel heel safe mesh	Bolt and bar (not included)	254	998	33 x 15	6,60	840478
	Stainless steel heel safe mesh	Bolt and bar (not included)	254	998	33 x 15	6,60	840483
	Galvanized steel square mesh	Bolt and bar (not included)	254	998	34.2 x 32.2	5,20	840479
	Stainless steel square mesh	Bolt and bar (not included)	254	998	34.2 x 32.2	5,20	840484
	Ductile iron mesh	Bolt and bar (not included)	254	498	21.5 x 17.5	5,85	840480
C 250							
	Ductile iron 13 mm slot	Bolt and bar (not included)	254	498	180 x 13	7,20	840481

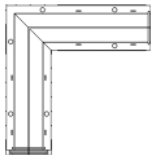
ACO Xtraline 200 grating accessories

Image	Description	Material	Valid for	Article number
	Bolt and bar kit + M8x40 TBL combi screw	Galvanized steel	ACO Xtraline 200 galvanized steel gratings	840806 ⁽¹⁾
		Stainless steel	ACO Xtraline 200 stainless steel gratings	840807 ⁽¹⁾
	Bolt and bar kit + M8x40 black hex head screw	Galvanized steel	ACO Xtraline 200 ductile iron gratings	840808 ⁽¹⁾

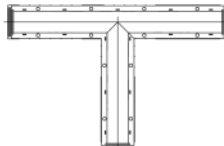
⁽¹⁾Valid for 1 meter of channel

ACO Xtraline range special parts

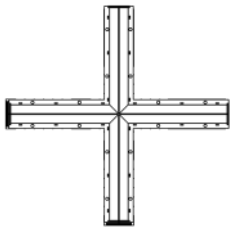
90° corner



"T" special part



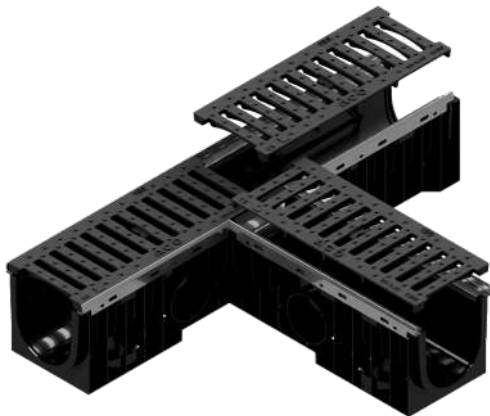
Cross special part



Article numbers and ICP on request

Main Features

- Special parts are available for all the Xtraline ranges
- Ductile iron, galvanized steel, stainless steel, HD-PE rail.
- Left or right 90° corners
- Left or right "T" special part
- Left or right cross special part
- Fixing system for each gratings
- Custom lenght special parts
- Male-male / female-female special parts





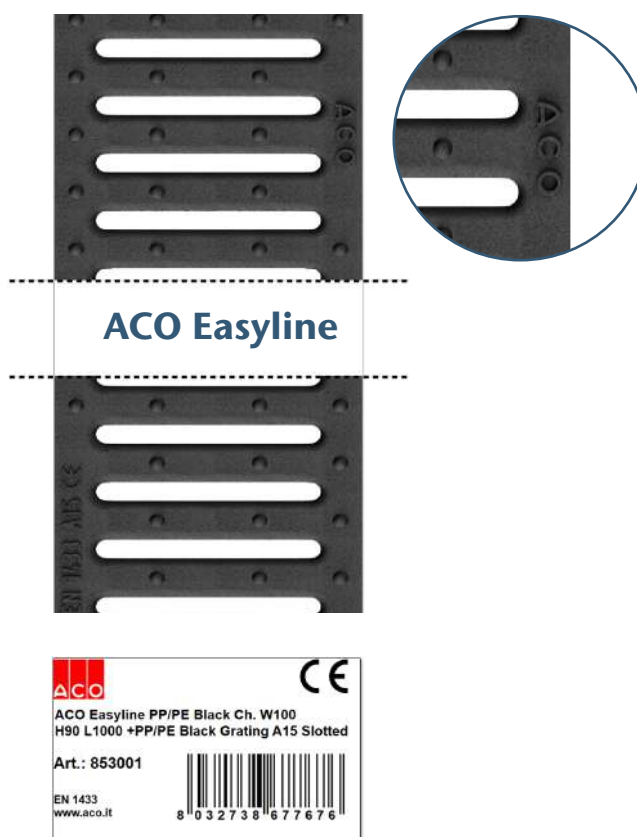
6


ACO Easyline

COLLECT:
Collect and convey



ACO Easyline H90	ACO Easyline H90, Black	P. 82
	ACO Easyline H90, Grey	P. 83
ACO Easyline H50	ACO Easyline H50, Black	P. 84
	ACO Easyline H50, Grey	P. 85
	ACO Easyline H50 PACK	P. 86




 Declaration of performance at:
www.aco.it/download/dop-e-certificati/

EXCELLENT PERFORMANCE FOR EVERYONE

ACO Easyline with grating is the ENTRY LEVEL range produced by ACO, equipped with all the features necessary to obtain safe and efficient drainage. The smooth and waterproof surface, the lightness, the special compact geometry and the guaranteed performances for the load classes A15 and B125, are the main features that make the **ACO Easyline with grating** unique in its kind.

The range includes two different heights: the **ACO Easyline** with 90mm internal height and the new arrival **ACO Easyline H50** with the new internal dimension of 30mm height. Thanks to these solutions, the **ACO Easyline with grating** can be installed and put into operation in a simple and easy way, without the help of special professional equipment, and this is precisely what makes it a product for everyone.

The gratings are fixed to the channel through a mechanical system with hooks, that do not require the use of bolts or nuts or special tools; an innovation that definitely simplifies the most traditional fixing systems.

The different models of **ACO Easyline with grating** can all claim of being CE marked, answering in this way to all the requirements of the European reference standard EN1433.

To protect and guarantee the declared and expected performance throughout its useful life in operation, the entire production chain is subject to strict quality controls that go well beyond those indicated as “minimum” by legislation.

Typical Applications

- Green areas
- Pedestrian areas and cycle paths
- Terraces and balconies



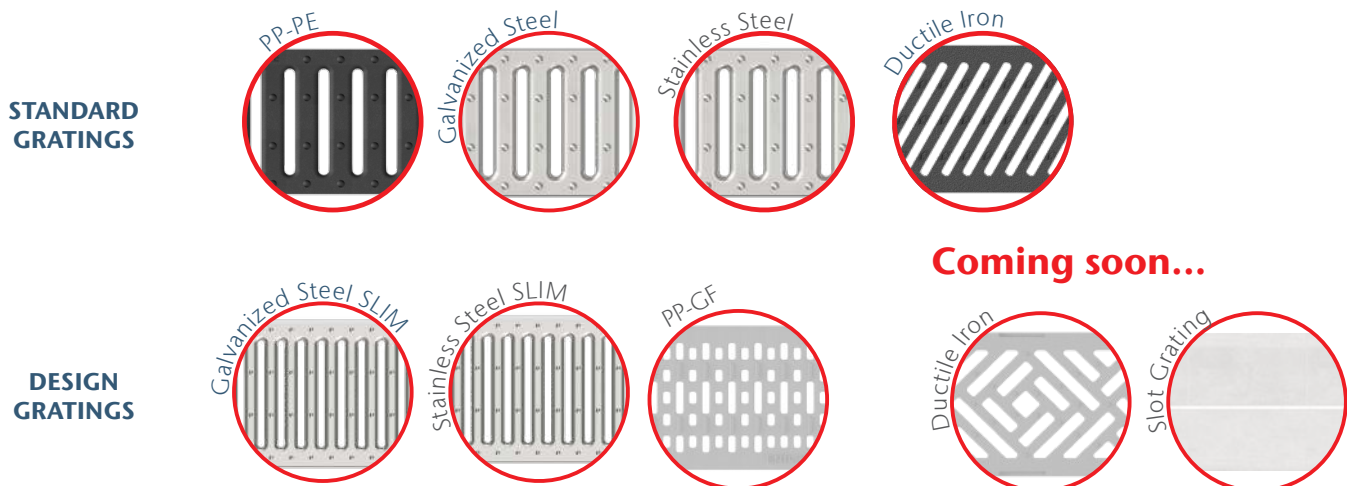
System overview ACO Easyline H90 NEW



System overview ACO Easyline H50



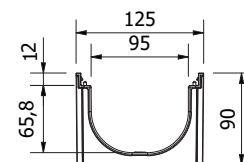
Standard gratings and design gratings



ACO Easyline H90, Black

Product information

- Plastic Channel BLACK
- Channel internal size (WxH): 95 x 66 mm
- PP-PE rail
- Gratings load classes A 15, B 125
- Built-in fixing system
- Available in Black and Grey color



ACO Easyline H90 BLACK with grating

Grating Type	Load Class	Slot	Dimensions			Pc/Pal	Artic. Num.
			Length	Width	Height		
		[mm]	[mm]	[mm]	[mm]	[n.]	
PP-PE	A 15	8	1000	120	90	72	853001
Galvanized steel	A 15	8	1000	120	90	72	853003
Stainless steel	A 15	8	1000	120	90	72	853007
Ductile iron	B 125	6	1000	120	90	72	853011
DESIGN GRATING Galvanized steel SLIM	A 15	5	1000	120	90	72	853005
DESIGN GRATING Stainless steel SLIM	A 15	5	1000	120	90	72	853009
DESIGN GRATING PP-GF	B 125		1000	120	90	72	853013
DESIGN GRATING Ductile Iron	B 125		1000	120	90	72	—
DESIGN GRATING Slot	A 15		1000	120	90	72	—

ACO Easyline H90 BLACK Kit

Description	Pc/Box	Artic. Num.
	[n.]	
ø110 vertical outlet + ø50 end cap outlet + num. 1 closing end cap	50	853200
ø50 end cap outlet + num. 1 closing end cap	50	853202

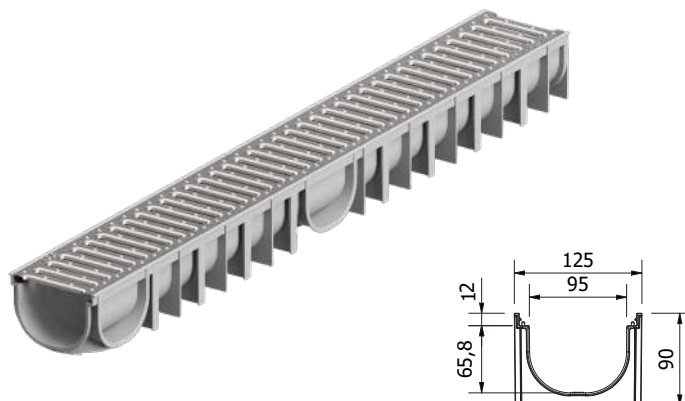
ACO Easyline H90 BLACK Accessories

Description	Pc/Box	Artic. Num.
	[n.]	
ø110 vertical outlet	100	853204
ø50 end cap outlet	100	853206
Closing end cap	100	853208

ACO Easyline H90, Grey

Product information

- Plastic Channel GREY
- Channel internal size (WxH): 95 x 66 mm
- PP-PE rail
- Gratings load classes A 15, B 125
- Built-in fixing system
- Available in Balck and Grey color



ACO Easyline H90 GREY with grating

Dimensions

Grating Type	Load Class	Slot	Dimensions				Pc/Pal	Artic. Num.
			Length	Width	Height			
		[mm]	[mm]	[mm]	[mm]	[n.]		
PP-PE	A 15	8	1000	120	90	72	855002	
Galvanized steel	A 15	8	1000	120	90	72	855004	
Stainless steel	A 15	8	1000	120	90	72	855008	
Ductile iron	B 125	6	1000	120	90	72	855012	
DESIGN GRATING Galvanized steel SLIM	A 15	5	1000	120	90	72	855006	
DESIGN GRATING Stainless steel SLIM	A 15	5	1000	120	90	72	855010	
DESIGN GRATING Ductile Iron	B 125		1000	120	90	72	—	
DESIGN GRATING Slot	A 15		1000	120	90	72	—	

ACO Easyline H90 GREY Kit

Description	Pc/Box	Artic. Num.
	[n.]	
ø110 vertical outlet + ø50 end cap outlet + num. 1 closing end cap	50	855201
ø50 end cap outlet + num. 1 closing end cap	50	855203

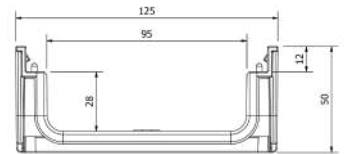
ACO Easyline H90 GREY Accessories

Description	Pc/Box	Artic. Num.
	[n.]	
ø110 vertical outlet	100	855205
ø50 end cap outlet	100	855207
Closing end cap	100	855209

ACO Easyline H50, Black

Product information

- Plastic Channel
- 4 side connections each channel
- Plastic rail 5mm thickness
- Gratings load classes A15, B125
- Built-in fixing system
- Available in Black and Grey color



ACO Easyline H50 BLACK with grating

Dimensions

Grating Type	Load Class	Slot [mm]	Dimensions			Pc/Pal [n.]	Artic. Num.
			Length [mm]	Width [mm]	Height [mm]		
PP-PE	A 15	8	1000	125	50	198	330004
Galvanized steel	A 15	8	1000	125	50	198	330000
Stainless steel	A 15	8	1000	125	50	198	330002
Ductile iron	B125	6	1000	125	50	198	330006
DESIGN GRATING Galvanized steel SLIM	A 15	8	1000	125	50	198	330008
DESIGN GRATING Stainless steel SLIM	A 15	8	1000	125	50	198	330012
DESIGN GRATING Ductile Iron	B 125		1000	125	50	198	—
DESIGN GRATING Slot	A 15		1000	125	50	198	—

ACO Easyline H50 BLACK Kit

Description	Pc/Box	Artic. Num.
	[n.]	
ø110 vertical outlet + num.2 ø32 end cap outlet + num.1 closing end cap	50	330020
ø32 end cap outlet + num.1 closing end cap	100	330040

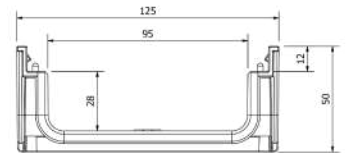
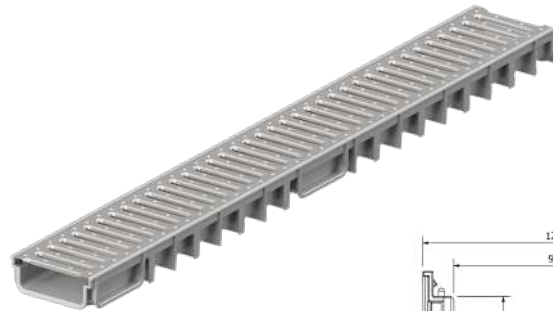
ACO Easyline H50 BLACK Accessories

Description	Pc/Box	Artic. Num.
	[n.]	
ø110 vertical outlet	100	319764
ø32 end cap outlet	100	330042
Closing end cap	100	330044

ACO Easyline H50, Grey

Product information

- Plastic Channel
- 4 side connections each channel
- Plastic rail 5mm thickness
- Gratings load classes A15, B125
- Built-in fixing system
- Available in Black and Grey color



ACO Easyline H50 GREY with grating

Dimensions

Grating Type	Load Class	Slot	Dimensions			Pc/Pal	Artic. Num.
			Length	Width	Height		
		[mm]	[mm]	[mm]	[mm]	[n.]	
PP-PE	A 15	8	1000	125	50	198	330200
Galvanized steel	A 15	8	1000	125	50	198	330202
Stainless steel	A 15	8	1000	125	50	198	330204
Ductile iron	B125	6	1000	125	50	198	330210
DESIGN GRATING Galvanized steel SLIM	A 15	8	1000	125	50	198	330206
DESIGN GRATING Stainless steel SLIM	A 15	8	1000	125	50	198	330208
DESIGN GRATING Ductile Iron	B 125		1000	125	50	198	—
DESIGN GRATING Slot	A 15		1000	125	50	198	—

ACO Easyline H50 GREY Kit

Description	Pc/Box	Artic. Num.
	[n.]	
ø110 vertical outlet + num.2 ø32 end cap outlet + num.1 closing end cap	50	330236
ø32 end cap outlet + num.1 closing end cap	100	330238

ACO Easyline H50 GREY Accessories

Description	Pc/Box	Artic. Num.
	[n.]	
ø110 vertical outlet	100	319765
ø32 end cap outlet	100	330421
Closing end cap	100	330243

ACO Easyline H50 Pack **NEW**

Product information

- The pack contains:
 - 4 plastic channels, 4 gratings, 2 open end caps, 1 closed end cap
- 4 side connections each channel
- Plastic rail 5mm thickness
- Gratings load class: A 15, B 125
- Built-in fixing system
- Available in Black and Grey color



ACO Easyline H50 BLACK

Grating Type	Load Class	Slot	Dimensions			Pc/Pal	Artic. Num.
			Length	Width	Height		
		[mm]	[mm]	[mm]	[mm]	[n.]	
PP-PE	A 15	8	1000	125	50	33	330300
Galvanized steel	A 15	8	1000	125	50	33	330302
Stainless steel	A 15	8	1000	125	50	33	330306
Ductile iron	B 125	6	1000	125	50	33	330312
DESIGN GRATING Galvanized steel SLIM	A 15	8	1000	125	50	33	330304
DESIGN GRATING Stainless steel SLIM	A 15	8	1000	125	50	33	330308

- Accessories on previous pages

ACO Easyline H50 GREY

Grating Type	Load Class	Slot	Dimensions			Pc/Pal	Artic. Num.
			Length	Width	Height		
		[mm]	[mm]	[mm]	[mm]	[n.]	
PP-PE	A 15	8	1000	125	50	33	330400
Galvanized steel	A 15	8	1000	125	50	33	330402
Stainless steel	A 15	8	1000	125	50	33	330406
Ductile iron	B 125	6	1000	125	50	33	330410
DESIGN GRATING Galvanized steel SLIM	A 15	8	1000	125	50	33	330404
DESIGN GRATING Stainless steel SLIM	A 15	8	1000	125	50	33	330408

- Accessories on previous pages

TERMS AND CONDITIONS

- Valid for orders from 01/02/2023
 - Transport condition: EXW MufleSystem warehouse
 - Payment terms: 30 DAYS AFTER INVOICE DATE
 - Minimum quantity:
 - ACO Xtraline, 1 pallet
 - ACO Easyline, half truck
-

MufleSystem S.r.l.

Via dell'Industria 7
62017 Porto Recanati (MC)
Tel. +39 071 9799122
Fax +39 071 7592275
info@mufle.com